

D6.1 Real world driving conditions and requirements for the LENS test programme



Deliverable No.	D6.1	
Deliverable title	Real world driving conditions and requirements for the LENS test programme	
Deliverable type	Report	
Dissemination level	Public	
Deliverable leader	TNO	
Contractual due date	31.05.2023	
Actual submission date	23.10.2023	
Version	2.0	
Written by	M. Dittrich, P. van Mensch, I. Riemersma, P. Paschinger (TNO), H. Steven (EMISIA/HSDAC), N. Karamanlis, P. Degeilhe (IFPEN)	19.10.2023
Reviewed by	K.M. Grugl (KTM), A. Garbi (IDIADA)	19.10.2023
Approved by	All partners	23.10.2023

Disclaimer

Funded by the European Union. Views and opinions expressed are however those of the author(s) only and do not necessarily reflect those of the European Commission or CINEA. Neither the European Commission nor CINEA can be held responsible for them.

Revisions table

Version	Date	Change
1.0	03.07.2023	First submission to the EC
2.0	23.10.2023	Submission to the EC -Inclusion of noise and vehicle driving profile measurements performed in July 2023 – Not yet approved by the EC



Table of contents

Revisions table	1
Executive summary	4
List of abbreviations	6
List of figures	6
List of tables	8
1 Introduction	10
1.1 Background and objectives	10
1.2 Approach and reader guide	11
2 Review and assessment of real world driving conditions	12
2.1 Literature review	13
2.1.1 Exhaust pollutant emissions	13
2.1.2 Noise emissions	15
2.2 Data sources	19
2.3 Comparison of the datasets	21
2.4 Assessment of critical driving conditions for pollutant emissions	31
2.4.1 Approach	31
2.4.2 Analysis of pollutant emissions for critical driving situations	32
2.5 Detection and occurrence of critical conditions in real-world data sources	41
2.5.1 Approach	41
2.5.2 Application of the indicated approach for the conditions specified in Table 2.3 and results for the EU WMTC database	43
2.6 Detection and occurrence of critical conditions in type approval cycles	50
2.7 Evaluation and validation for noise emissions	50
2.8 Evaluation and validation for pollutant emissions	55
2.9 Fleet composition	58
3 Occurance of critical conditions in legislative test cycles	61
3.1 TA Regulations for noise	61
3.2 TA Regulations for pollutant emissions	66
3.3 Comparison of TA with RW driving conditions assessment	70
3.3.1 Noise	70
3.3.2 Emissions	75



4	Conclusions and recommendations on requirements for the test programme	78
4.1	Test vehicles	78
4.2	Critical events for noise measurement.....	78
4.3	Critical events for pollutant emission measurements	80
5	References.....	82
	Annex A Overview of L-category vehicles.....	85
	Annex B Examples of sound characteristics	86
	Annex C Additional vehicle emission data.....	135
	CO emissions of a moped	135
	HC emissions of a moped.....	137
	CO emissions of a motorcycle	140
	HC emissions of a motorcycle	142
	RDE data of moped A.....	145
	RDE data of moped B.....	147
	RDE data of moped C	148



Executive summary

In the LENS project, an investigation has been made into the driving conditions of L-category vehicles that are relevant for high noise and pollutant emission events. The L-category includes motorcycles, mopeds and scooters, quads, trikes, and quadricycles.

The following steps were undertaken:

- Review of existing knowledge on real world driving conditions from previous projects, WMTC development, manufacturer data and the public domain
- Identification of L-vehicle operation and critical driving conditions for noise and emissions
- Targeted roadside/on board measurements to validate preliminary findings on critical cases
- Assessment to what extent current type approval regulations cover real world driving conditions
- Provision of requirements for operating conditions coverage by the main test programme.

Review and data analysis

A literature review and analysis of available real world driving data was performed to determine which critical conditions have been identified for noise and pollutant emissions in the past.

Conditions for high noise levels

Starting with evidence from previous noise measurements in real traffic situations at urban locations with noise complaints about loud vehicles, a series of conditions for high noise levels were identified such as fast acceleration, engine revving and high continuous engine speed.

Roadside traffic measurements were performed at three sites in Utrecht providing further evidence of proposed driving conditions for high noise emission. These were best visualised with sound spectrograms, which show engine speed related harmonics with their characteristic patterns for each condition.

Conditions for high emission levels

As the conditions for high noise levels were expected to also be relevant for tailpipe emissions, the available driving and emission data were analysed to determine to what extent these are present. Not all of the conditions could be identified from these data due to the fact that emission data was mainly available on specific (type-approval) driving profiles and aksj because of a lack of engine speed data. It was concluded that elevated emissions potentially occur at the following conditions:

- Cold engine start;
- Driving at maximum configuration speed (mainly for mopeds);
- Strong accelerations;
- Transition from constant speed or acceleration phases to deceleration phases.

In addition, some elements could not be evaluated due to a lack of data but may lead to increased emissions. These are:



- Restarting during the test;
- Testing at maximum technically permissible mass;
- Stop and go testing simulating traffic congestion (idling and cold aftertreatment);
- Engine revving.

Evaluation of type approval tests

The type approval tests for L-vehicles are substantially different for noise and emissions. For noise, sound levels of pass-by and stationary vehicles are determined on a test track, whereas for pollutant emissions a driving cycle is applied to a vehicle on a chassis dynamometer. Many of the identified high noise and emission events are not specifically covered by the type approval test, because they are more focussed on average conditions or cumulative data. It is suggested that they can be included in testing either on road, or on a test track.

Recommendations for the LENS test programme

The main recommendation is to include and evaluate the identified driving conditions as described above – which are set out in detail in chapter 4 - in the main LENS test programme of WP3 and WP4 where possible. It is also recommended to record – besides noise and emission levels - engine speed, vehicle speed, gear setting, exhaust gas temperature, total vehicle mass including rider and equipment, and road slope. The findings can then be used later to identify possible improvements to the type test procedures, either in the pass-by noise test, roadside enforcement noise test or emissions testing.

For emission measurements, the identified driving conditions can be integrated in the on-road measurement campaign, by using PEMS or SEMS equipment. For the testing program it is recommended to assess the cold start impact separately from the rest of the test. The approach as taken in the proposed Euro 7 legislation for Light Duty Vehicles (LDVs) can be used as a basis for this. Therefore, a possible solution to assess cold start emissions is by introducing an emission “budget”, such as proposed in Euro 7 (this budget is a cap on emissions for the first 10 km of a trip to address cold start emissions).

An analysis of the EU fleet composition was also made, based on registration data. It is recommended to use this fleet data to check the representativeness of vehicles in the test programme, distribution between individual countries and potential impact of Euro class groups and L-vehicle sub-categories.

It is recommended to use in-service vehicles from the market for the test programme, with a minimum mileage of 3000 km.



List of abbreviations

WMTC	World Motorcycle Test Cycle
HS DAC	HS Data Analysis and Consultancy
ASEP	Additional Sound Emission Provisions
WOT	Wide Open Throttle
RPA	Relative Positive Acceleration
RNA	Relative Negative Acceleration
CVT	Continuous Variable Transmission

List of figures

Figure 2-1: Overview of the structure for Chapter 2	12
Figure 2-2: Noise emission of a sports bike in dependence of engine speed and vehicle speed modelled for in-use data of the WMTC database. (Leng_k – noise emission at low or no load condition, Leng_w – noise emission at wide open throttle or full load condition, Lg – second by second noise emission for the in-use data)	16
Figure 2-3: Occurrence of events with particular sound labels at 3 locations during 5/10 days in Rotterdam, for identified vehicles and near the monitoring positions. fconthi is the same as rpmconthi	18
Figure 2-4: Occurrence of events with particular sound labels at 3 locations during 5 days in the Hague,	18
Figure 2-5: Trip or route distance distributions for the different L-category vehicles datasets	22
Figure 2-6: Distributions of average speed values per trip	23
Figure 2-7: Distributions of maximum speed values per trip	23
Figure 2-8: Distributions of vehicle speeds for the different vehicle classes as specified above	24
Figure 2-9: Distributions of acceleration values at vehicle speeds around 30 km/h for the different vehicle classes as specified above	25
Figure 2-10: Distributions of acceleration values at vehicle speeds around 70 km/h for the	25
Figure 2-11: Specific cumulative energy on the wheel binned by road gradient and relative occurrence frequency of each road gradient bin – IFPEN Database	28
Figure 2-12: Specific cumulative energy on the wheel binned by road gradient and relative occurrence	28
Figure 2-13: Specific cumulative energy on the wheel binned by road gradient and relative occurrence frequency of each road gradient bin – Payload addition (second passenger)	29
Figure 2-14: Instantaneous power ratio probability distribution	31
Figure 2-15: Instantaneous NO _x mass emission of different tests	35
Figure 2-16: NO _x emission map of a moped on the UN ECE R47 cycle	36
Figure 2-17: NO _x emission map of a moped on the UN ECE R47 cycle (cold start phase)	36
Figure 2-18: NO _x emission map of a moped on the UN ECE R47 cycle (warm start phase)	37
Figure 2-19: Combined NO _x emission map of a moped	38
Figure 2-20: Instantaneous NO _x mass emission of the WMTC Stage 2 test	39
Figure 2-21: NO _x emission map of a motorcycle on the WMTC Stage 2 cycle	39
Figure 2-22: NO _x emission map of a motorcycle on the WMTC Stage 2 cycle (cold start phase)	40
Figure 2-23: NO _x emission map of a motorcycle on the WMTC Stage 2 cycle (warm phase)	40
Figure 2-24: v _{start} frequency distributions for acc phases > 2 s	46



Figure 2-25: v_{ave} frequency distributions for cruise phases > 2 s	47
Figure 2-26: Three urban measurement locations in Utrecht for roadside monitoring of loud vehicles, indicated with WD (top), TK (middle) and AS (bottom).	51
Figure 2-27: Measurement configuration. The dimensions a-g are different for each site, listed in Annex B.	52
Figure 2-28: Histogram of vehicle sound labels for loud vehicles at 3 sites in Utrecht	53
Figure 2-29: Histogram of vehicle sound levels per vehicle type for loud vehicles at 3 sites in Utrecht for 7 days each	53
Figure 2-30: Vehicle pass-by sound levels L_{pAFmax} above 80 dB(A) for three locations measured at two roadside positions. Top: showing vehicle type where identified; bottom: same data but indicating the vehicle sound label.	54
Figure 2-31: Maximum acceleration distribution for radar measurements at the first two locations in Utrecht	56
Figure 2-32: Maximum acceleration distribution for WMTC part I (urban part)	57
Figure 2-33: Fleet numbers of L-vehicles in whole EU27 in 2020	59
Figure 2-34: Percentage of EU27 L-vehicle fleet in individual member states in 2020	59
Figure 2-35: Fleet numbers of L-vehicles in EU27 member states with the largest fleets (>5% of EU27 fleet) in 2020	60
Figure 2-36: Figure 4: Euro class of L-vehicles in the EU27 fleet in 2020. 'Conventional' refer to vehicles without Euro class number, which are from before its introduction	60
Figure 3-1: Test setup for pass-by sound measurement for L-vehicles. The vehicle approaches AA' and proceeds with wide open throttle, which is released at BB'.	62
Figure 3-2: Test setup for stationary sound measurement of L-vehicles for roadside checks. The engine runs at constant specified speed, and the throttle is released.	62
Figure 3-3: Example of ASEP test range showing the ASEP sound limit line based on the reference point from the normal WOT test. Any points measured for ASEP must be below the limit line. Taken from IMMA presentation at GRB ASEP meeting 11-13 July 2017 [12].	63
Figure 3-4: The final approximation function for upshift speeds in gears higher than 1 (1/3 Europe, 1/3 Japan, 1/3 USA). From ECE/TRANS/180/Add.2/Appendix 1 (Technical Report to GTR 2), s means rated engine speed	71
Figure 3-5: Vehicle and engine speed time series of the WMTC cycle for vehicle 3 of the EU WMTC in use database	72
Figure 3-6: Engine speed versus vehicle speed plots for the WMTC cycle and WMTC in-use data for vehicle 3	73
Figure 3-7: Vehicle speed and engine speed time series of the WMTC cycle for vehicle 37 of the EU WMTC in use database	74
Figure 3-8: Engine speed versus vehicle speed plots for the WMTC cycle and WMTC in-use data for vehicle 37	75
Figure 3-9: Vehicle speed time series of the WMTC cycle (left figure is for class 1 vehicles only)	76
Figure A-1: L-vehicle types Source: [31]	85
Figure B-1: Sound characteristics of a quad, example of 'rpmburst'	87
Figure B-2: Sound characteristics of a motorcycle, example of 'rpmburst'	88
Figure B-3: Sound characteristics of a motorcycle, example of 'rpmshortacc'	89
Figure B-4: Sound characteristics of a scooter, example of 'rpmshortacc'	90
Figure B-5: Sound characteristics of a motorcycle, example of 'rpmshortacc'	91
Figure B-6: Sound characteristics of a motorcycle, example of 'rpmshortacc'	92
Figure B-7: Sound characteristics of a motorcycle, example of 'rpmshortacc'	93
Figure B-8: Sound characteristics of a moped, example of 'rpmshortacc'	94
Figure B-9: Sound characteristics of a 3-wheeld scooter, example of 'rpmshortacc'	95
Figure B-10: Sound characteristics of a motorcycle, example of 'rpmburst' due to high speed and close range	96
Figure B-11: Sound characteristics of a moped, example of 'fconthi/rpmconthi'	97
Figure B-12: Sound characteristics of a trike, example of 'rpmlongacc'	98
Figure B-13: Sound characteristics of a motorcycle, example of 'rpmburst'	99
Figure B-14: Sound characteristics of a motorcycle, example of 'rpmburst'	100
Figure B-15: Sound characteristics of a motorcycle, example of 'rpmshortacc'	101
Figure B-16: Sound characteristics of a moped, example of 'rpmburst'	102
Figure B-17: Sound characteristics of a motorcycle, example of 'rpmshortacc'	103



Figure B-18: Sound characteristics of a moped, example of 'rpmconthi'	104
Figure B-19: Sound characteristics of a motorcycle, example of 'rpmburst'	105
Figure B-20: Sound characteristics of a motorcycle, example of 'rpmburst'	106
Figure B-21: Sound characteristics of a motorcycle, example of 'rpmshortacc'	107
Figure B-22: Sound characteristics of a trike, example of 'rpmburst'	108
Figure B-23: Sound characteristics of a motorcycle, example of 'rpmburst'	109
Figure B-24: Sound characteristics of a motorcycle, example of 'rpmlongacc'	110
Figure B-25: Sound characteristics of a quad, example of 'rpmburst'	111
Figure B-26: Sound characteristics of a motorcycle, example of 'rpmburst'	112
Figure C-1: Overview of CO emissions of different test cycles	135
Figure C-2: CO emission map (whole test)	135
Figure C-3: CO emission map (cold phase)	136
Figure C-4: CO emission map (warm phase)	136
Figure C-5: CO emission map (all tests combined)	137
Figure C-6: Overview of HC emissions of different test cycles	137
Figure C-7: HC emission map (whole test)	138
Figure C-8: HC emission map (cold phase)	138
Figure C-9: HC emission map (warm phase)	139
Figure C-10: HC emission map (all tests combined)	139
Figure C-11: Overview of CO emissions	140
Figure C-12: CO emission map (whole test)	140
Figure C-13: CO emission map (cold phase)	141
Figure C-14: CO emission map (warm phase)	141
Figure C-15: CO emission map (all tests combined)	142
Figure C-16: Overview of HC emissions	142
Figure C-17: HC emission map (whole test)	143
Figure C-18: HC emission map (cold phase)	143
Figure C-19: HC emission map (warm phase)	144
Figure C-20: HC emission map (all tests combined)	144
Figure C-21: NO emissions of moped A	145
Figure C-22: CO emissions of moped A	146
Figure C-23: HC emissions of moped A	146
Figure C-24: NO emissions of moped B	147
Figure C-25: CO emissions of moped B	147
Figure C-26: HC emissions of moped B	148
Figure C-27: NO emissions of moped C	148
Figure C-28: CO emissions of moped C	149
Figure C-29: HC emissions of moped C	149

List of tables

Table 2.1: LV driving conditions for which loud vehicle noise is expected.	17
Table 2.2: LV driving conditions for which high pollutant emissions are expected	41
Table 2.3: Critical LV driving conditions further specified	42
Table 2.4: Occurrence of driving conditions 1 & 2 in the EU WMTC database (timeshares).	44
Table 2.5: Occurrence of driving condition 3 in the EU WMTC database	45
Table 2.6: Occurrence of driving condition 4 (for v_{ave} values between 80 km/h and 90 km/h) in the EU WMTC database	47



Table 2.7: Filtering results for condition 5a (deceleration phases following a cruise phase) for the EU WMTC database	48
Table 2.8: Filtering results for condition 5b (deceleration phases following an acceleration phase) for the EU WMTC database	48
Table 2.9: Filtering results for condition 6 (engine speed bursts at standstill) for the EU WMTC database	49
Table 3.1: Applicable UNECE Regulations for sound type approval of L-category vehicles	64
Table 3.2: Summary of UNECE TA sound test methods for L-vehicles	65
Table 3.3: Changes for new revision of ASEP for motorcycles, from GRBP ASEP 16th session June 2020	65
Table 3.4: Key changes to emissions legislation L-category vehicles	66
Table 3.5: Emission limits L-category vehicles relative to M1 vehicles	67
Table 3.6: Applicable driving cycle per vehicle category and Euro class [31]	68
Table 3.7: WMTC vehicle classification per vehicle type [31]	68
Table 3.8: Summary of the specifications of the cycles [31]	69
Table 4.1: Recommended driving conditions for the noise test programme, ordered in possible test sequence	79
Table 4.2: Recommended driving conditions for the tailpipe emissions programme, ordered in possible test sequence.	81



1 Introduction

1.1 Background and objectives

Noise and emissions of L-vehicles, as defined in Regulation (EU) 168/2013 are the main focus of the LENS project. These include motorcycles, mopeds and scooters, quads, trikes and quadricycles. A complete overview is given in Annex A. Considering the need to reduce noise and pollutant emissions in real world situations, an assessment is required to identify critical driving conditions under which high noise and emissions occur. Although legislation and type approval mainly consider average conditions, much of the local environmental impact is caused by specific conditions under which the highest noise levels and emissions occur. For example, noise impacts such as serious annoyance and sleep disturbance are often at specific times, locations, driving and vehicle conditions and parts of the fleet. Therefore, some knowledge of the fleet composition is needed to find which vehicle groups are most numerous.

In real world conditions, noise and emissions depend not only on the vehicle specifications and characteristics, but also driving behaviour, vehicle modifications and wear. Vehicle modifications are not the main focus of this report but need to be considered when assessing real world noise and emissions. As there are many modifications possible, these need to be identified. A separate workflow in LENS, WP5, investigates this in more detail.

Whereas noise may lead to citizen complaints, emissions may not do so directly, but may result in health impacts.

Within the LENS project, a major measurement campaign on 150 vehicles is planned, including on-road, laboratory, test track and roadside measurements. This is intended to support proposals for improvement of the type approval test procedures and possible enforcement measures (i.e. road-side checks and market surveillance). In addition, further work includes proposing solutions for mitigation and impact assessment.

Work package 6 covers ***Assessment and policy recommendations***. This report serves as a starting point for the above topics in the LENS project, being the first deliverable in WP6 and focussing on ***Driving conditions and requirements for a test programme based on real world evidence of LVs operation***.

The objectives are as follows:

- Collate and review existing knowledge (previous projects, WMTC development, OEM data, public domain) on real world driving conditions
- Identify LV operation and critical driving conditions for noise and exhaust emissions
- Perform targeted roadside/on board measurements to validate preliminary findings on critical cases
- Assess to what extent current TA regulations cover RW driving conditions
- Issue requirements on operating conditions coverage by the main test programme



The partners involved in this work package were:

TNO (lead author), EMISIA/HS Data (co-author), IFPEN (co-author), IVL, IDIADA, KTM, BMW Group and Piaggio.

1.2 Approach and reader guide

Following the objectives, the analysis follows in subsequent chapters:

- Chapter 2:
 - A review of existing available knowledge and data on real world driving conditions from previous projects, WMTC development, OEM data, and the public domain.
 - LV operation and critical driving conditions for noise and exhaust emissions
 - Targeted roadside/on board measurements to validate preliminary findings on critical cases
- Chapter 3: Assessment to what extent current TA regulations cover RW driving conditions
- Chapter 4: Conclusions and recommendations for the test programme.

This report is public, and therefore for a broader audience, both in relation to research and practical understanding of real-world driving conditions relevant for noise and emissions of L-vehicles.

It also serves as an input for further work packages in the LENS project, in particular for the measurement programme, mitigation proposals and impact assessment.



2 Review and assessment of real world driving conditions

The basis for the evaluation of critical noise and pollutant emission events is formed by a set of data sources which are analysed and assessed in this chapter. The structure is as follows:

Section 2.1 provides a review of relevant literature that sets out existing knowledge and data in the area of noise and pollutant emissions from L-category vehicles. The data sources that have been gathered in the LENS project, provided by several partners, are described in section 2.2. In section 2.3 a comparative analysis of the data sources is performed, which gives insight into the representativeness of the various data sources. The in-depth analysis of the data including the chosen approach is outlined in section 2.4, which also deals with the overlap of critical driving conditions for noise with those that are critical for pollutant emissions. After these conditions have been established, they are parameterised in section 2.5. Based on that parameterisation, the data sources are filtered (section 2.6) to determine the real-world occurrence of these critical driving conditions. Section 2.7 covers the evaluation and validation of these results for noise, based on available data from roadside measurement. Finally, section 2.8 contains an overview of the current L-category vehicle fleet in Europe, which is intended to support the process of vehicle selection in WP 3 and 4. The scheme in Figure 2-1 illustrates how the analysis steps and sections in chapters 2 and 3 are related.

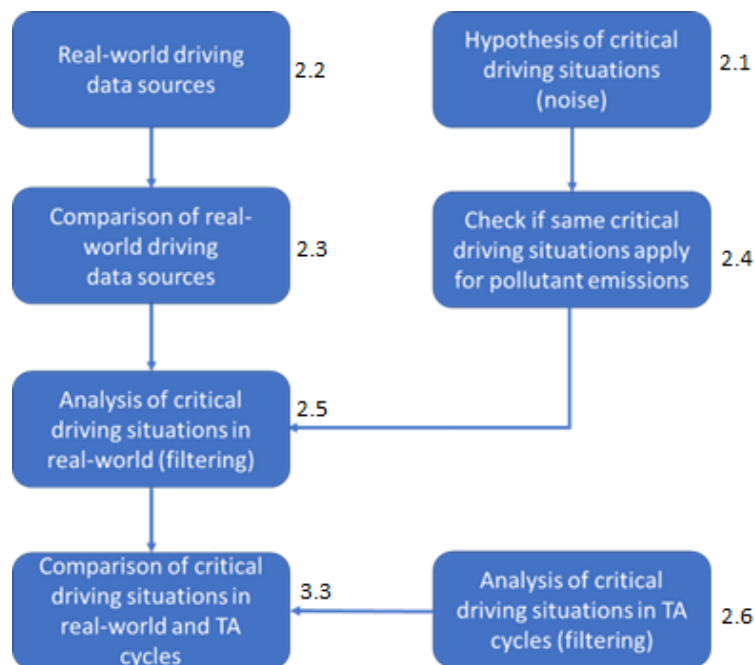

Figure 2-1: Overview of the structure for Chapter 2



2.1 Literature review

2.1.1 Exhaust pollutant emissions

Driving cycles have been developed in the past, in particular for vehicle emission testing. Test cycles for emissions are required to cover multiple driving conditions over a given distance. They are characterised by a speed profile and are intended to cover typically average total emissions. Such tests are generally performed on a chassis dynamometer. Section 3.2 describes the driving cycles applied for exhaust emissions in the type approval regulations in more detail.

WMTC development

For motorcycles, the World Motorcycle Test Cycle (WMTC) was developed from 1999 [21]. The Worldwide Motorcycle Test Cycle (WMTC) was originally a tripartite project between the Netherlands Ministry of the Environment (VROM), TNO Automotive, and the International Motorcycle Manufacturer Association (IMMA) in 1999. VROM handled the policy aspects, TNO Automotive conducted the technical management, and IMMA collected data on in-use driving behaviour. Later, in May 2000, the project was placed under the UN/ECE WP 29, which mandated the ad-hoc group WMTC to develop a World-wide Harmonized Motorcycle Emissions Certification/Test Procedure and establish it under the framework of the 1998 Agreement on Global Technical Regulations (GTR), where it was published as GTR No. 2 [21].

The World-wide Motorcycle Test Cycle (WMTC) was developed based on in-use driving behaviour data and statistical information about motorcycle use from different regions, vehicle classes, and road categories. A classification matrix was used to create a reference database, which was then compacted into a test cycle of the desired length [21]. Several iterations were carried out to evaluate the driveability and practical points of the WMTC, resulting in a first draft that needed further modifications.

The World-wide Motorcycle Test Cycle (WMTC) was developed by dividing the cycle into three parts, each representing a different road category, and incorporated a cold start. The emissions are measured separately for each part. Provisional vehicle classification and weightings were used to take into account vehicle use statistics.

Later, the emission legislation has been completely revised (which also included revisions of the test cycles) for the entire L-category, as detailed in Regulation (EU) 168/2013 and Delegated Regulation (EU) 134/2014. The updated legislation sets forth Euro 4 emission limits and procedures, which took effect in 2016¹ for new vehicle types and 2017¹ for existing vehicle types. The Euro 5 limits became effective in 2020 for new vehicle types and in 2021 for existing vehicle types. Section 3.2 describes the most important changes in the type approval in more detail.

¹ For L1e, L2e and L6e vehicles the introduction date is one year later.



Influencing parameters for exhaust emissions

In the study of B.Giechaskiel, A.Zardini & G.Martini (Particle Emission Measurements form L-Category Vehicles) it is shown that the emission of particles are in general higher with a **cold engine** [22].

A study of A. Zardini et. al, where mopeds were measured, the negative impact of the cold start is shown on the emissions of CO, THC and PM as well [44].

In a study of Hensema, A., Mensch, P. v. & Vermeulen (Tail-pipe emissions and fuel consumption of standard and tampered mopeds), several mopeds were tested [25]. This study showed an elevated fuel consumption and elevated emissions when driving at **maximum construction speed (full throttle)**, and during **accelerations**. The speed limiters, applied on those mopeds (Euro 2), had a very negative impact on fuel consumption as they simply avoid ignition of the combustion mixture by the spark plug above the construction speed. After removal of the speed limiters, while driving on the same speed, the fuel consumption decreased substantially. A study by Arjan Eijk, Pim van Mensch, Mitch Elstgeest (Tailpipe emissions of mopeds in the Dutch fleet) showed similar results, however, the moped with electronic fuel injection instead of a carburettor (like Euro 4 and 5 mopeds) showed no increase in fuel consumption at maximum construction speed (compared to a slightly lower speed) [28]. This study also showed elevated CO-emissions for a number of mopeds while the engine was warm, indicating a poor functionality of the applied emission control devices. This shows the need of testing **in-service vehicles**.

In the Euro 5 effect study [31], measurements in real-world circumstances on the road were performed. During these tests, higher maximum speeds and higher accelerations occurred. For example, the $v \cdot a$ positive values were for the mopeds and heavy motorcycles (class 3_2), substantially higher during the on road test, than during the WMTC. However, for mopeds, the R47 test ("Emission of gaseous pollutants of mopeds") showed the highest $v \cdot a$ positive values (due to the full load accelerations). The R47 seems to be a quite demanding cycle for mopeds.

On-road testing with PEMS

In the study "Effect study of the environmental step Euro 5 for L-category vehicles" [31], an experimental test campaign with a mini-PEMS was performed. Some compromises were made to keep the applied PEMS small and light, like no direct exhaust flow measurement, no heated lines and different analysers. The PEMS applied in this particular study did not reached the accuracy and applicability as the PEMSs which are applied for light- and heavy duty vehicles. The emission measurement results are briefly discussed in section 2.4, it was however an experimental test campaign, and therefore the results can only be considered indicative.

It was concluded that it can be challenging to develop an accurate and small PEMS with sufficient autonomy. Nevertheless, it was concluded that measurements with PEMS on L-category vehicles are technically feasible for future legislation and that this is the most suitable method for the determination of off-cycle emissions. It was also concluded that representative real-world driving can influence emissions firmly, and that those conditions can be more comprehensive than the WMTC driving conditions.



2.1.2 Noise emissions

In contrast to exhaust pollutant emissions, noise testing for L-vehicles is done for a limited set of test conditions at a test site, including acceleration, constant speed and stationary conditions. Originally, the wide-open throttle test (WOT) was the primary test for a moving vehicle, but in UN R41 for motorcycles this was later modified to a combined acceleration and constant speed test in a similar way as for cars in UN R51. UN R41 was developed to be representative of average conditions and extended with ASEP (see chapter 3) to cover a wider range.

In recent years, more studies have been done on noise emission along urban and rural roads where noise disturbance occurs, based on complaints, and mitigation measures [32][33][34][35][36][37][38][39]. It is well known that high noise levels are often due to driving behaviour and/or vehicle modifications, but also new vehicles can produce high noise levels under certain conditions such as high acceleration and high rpm. In general, it can be expected that high engine speed and/or acceleration will also produce higher emissions, and these conditions may also partly occur in emissions test cycles.

Influencing parameters for noise emission

The most important parameters for the noise emission of L-category vehicles are engine speed and engine load, influencing the noise emission of the engine and the exhaust system (see Figure 2-2). For small vehicles the transmission could also contribute to the overall noise emission which could add a vehicle speed dependent component. In contrast to these, the rolling noise emission is of minor importance except for off-road vehicles. From this figure it can be concluded that high noise emissions are related to high acceleration events at high engine load, which result in high engine speeds and high vehicle speeds. High vehicle speeds require high power demand and thus lead to high engine speeds, especially for small vehicles.



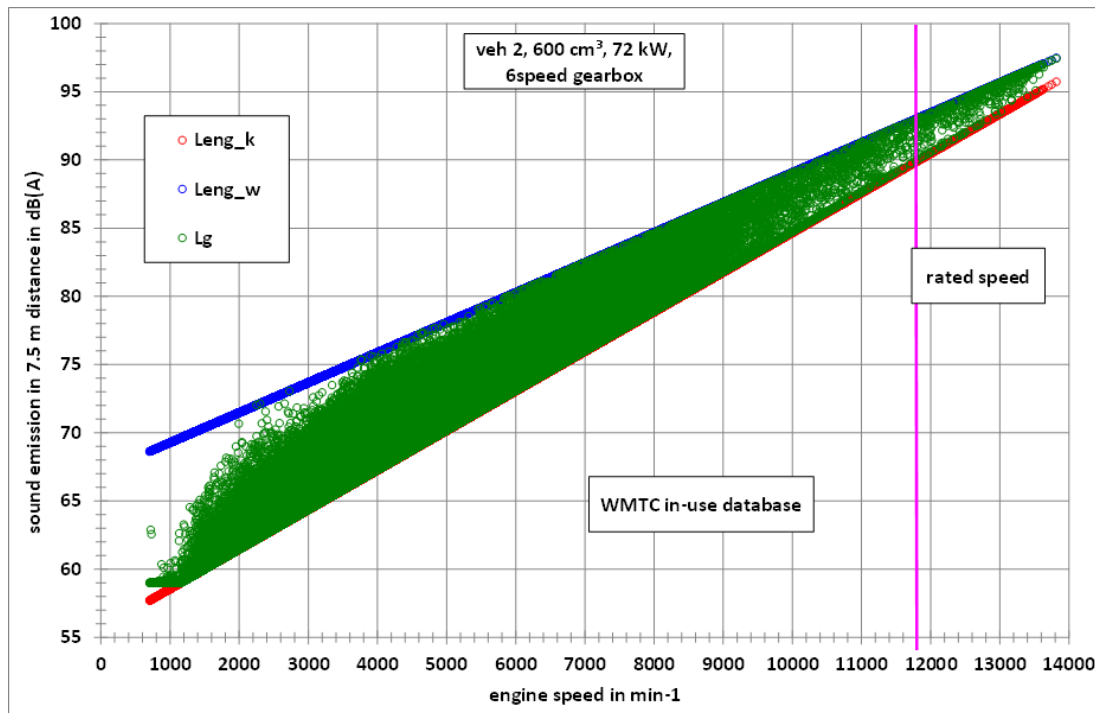

Figure 2-2: Noise emission of a sports bike in dependence of engine speed and vehicle speed modelled for in-use data of the WMTC database. (Leng_k – noise emission at low or no load condition, Leng_w – noise emission at wide open throttle or full load condition, Lg – second by second noise emission for the in-use data)

Roadside vehicle noise monitoring in the Netherlands

In the Netherlands in 2021-2022, roadside vehicle noise monitoring in normal traffic was performed in urban situations in several major cities [37][38][39]. The focus was on loud cars and L-vehicles at locations selected based on complaints. Within the normal traffic flow, hundreds of loud vehicles were identified by numberplate registration (ANPR cameras) and characterised in terms of sound level and features. The sound signals, images, video and vehicle characteristics were stored and analysed showing how sound spectrograms and other quantities can be used to identify driving behaviour and potentially modified vehicles. The purpose of these measurements was to evaluate the types of vehicles producing high noise levels, the potential causes and subsequently to derive solutions for mitigation.

These studies are relevant for LENS, as they provide evidence of real world driving conditions for high sound levels. The most relevant conditions were identified based on the actual measurements and the principal physics. These are listed in Table 2.1 below and expanded with some additional ones.



Table 2.1: LV driving conditions for which loud vehicle noise is expected.

Condition	Vehicle operation	Short name	Associated modification
'max' acceleration from standstill, G1, G2	Acceleration	'rpmshortacc'	Power
acceleration from standstill, G1, G2 Loaded + unloaded	Acceleration, late gear change	'rpmlongacc'	Power
Acceleration at speed from 50 to 100 kmh	Acceleration, maybe varied	'rpmmidsspeedacc'	Power/rpm
max rpm passby esp. mopeds, scooters, sports MCs	Constant speed with max rpm	'rpmconthi'	Power/rpm/ exhaust
release from constant speed	Decelerating	'rpmdropoff'	
rpm burst	Stationary	'rpmburst'	
rpm fluctuation	Variable	'rpmfluct'	
backfire (occurrence, distance not critical)	Multiple gear changing or manual operation	'bang'	Fuel/ECU/other
Cold start (mainly for emissions)	Engine start	'coldstart'	

Most of these sound characteristics can be linked to specific driving conditions/behaviour or vehicle conditions or components. As they are also associated with engine power output, they are generally also considered relevant for high emissions. But for application in vehicle testing, they require further definition in terms of measurement parameters and conditions. Some examples of vehicle sound events with these characteristics are given in Annex B. Statistics of the sound labels are shown for measurements in Rotterdam and The Hague in 2022 in Figure 2-3 and Figure 2-4. The most frequent sound labels are *fconthi* (or *rpmconthi*), *rpmburst*, and *rpmshortacc*. Followed by *rpmlongacc*. Although the other conditions scored low at these locations, this does not mean they can be ruled out. *Rpmdrop* and *rpmfluct* may be more common for decelerating vehicles at other locations, whereas *bang* can be very location specific and often not occur directly near the microphone position.



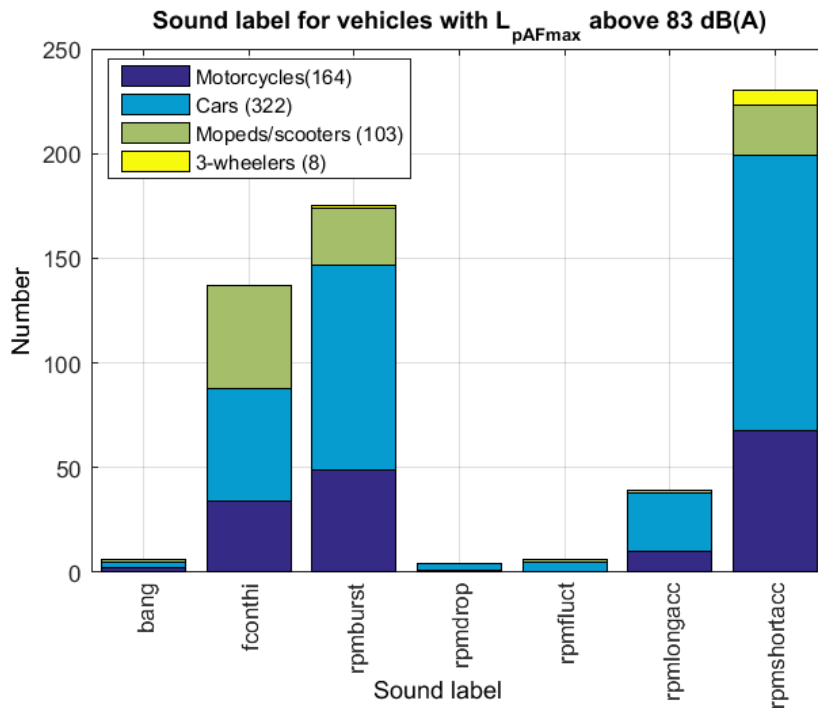

Figure 2-3: Occurrence of events with particular sound labels at 3 locations during 5/10 days in Rotterdam, for identified vehicles and near the monitoring positions. fconthi is the same as rpbmconthi

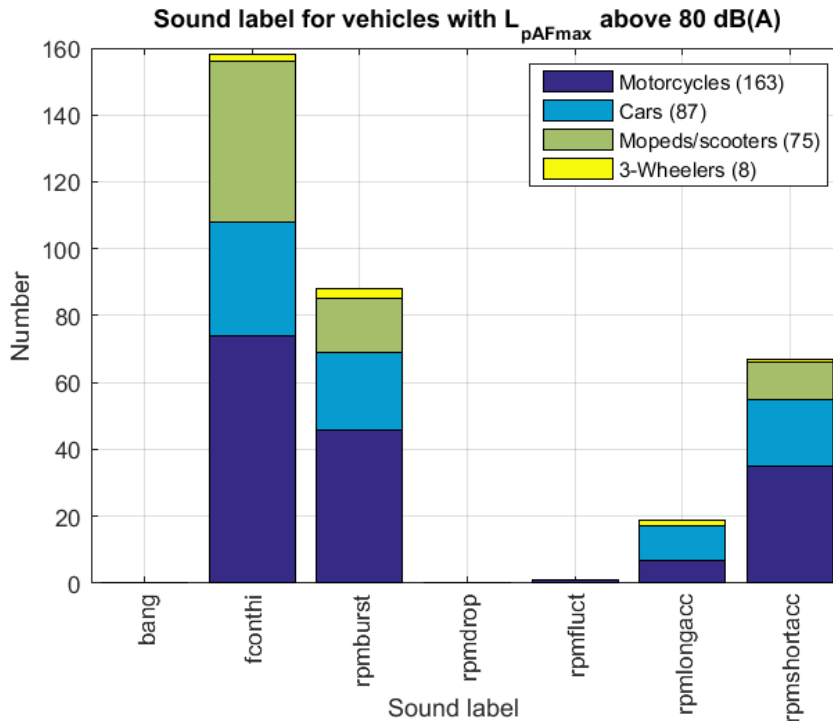

Figure 2-4: Occurrence of events with particular sound labels at 3 locations during 5 days in the Hague, for identified vehicles and near the monitoring positions. fconthi is the same as rpbmconthi



The proposed conditions above are probably incomplete, as they have been observed at specific urban locations and based on high noise events. It still needs to be checked to what extent the following are sufficiently covered, both for noise and emissions:

- Testing at maximum technically permissible mass
- Stop and go testing simulating traffic congestion (idling and cold aftertreatment)
- Strong acceleration from standstill to maximum speed (full pedal and simulating accelerations after entering the motorway)
- Aggressive driving (dynamic shifting)
- Other high load events and high rpm events.
- Driving at high vehicle speed (100 km/h – v_{max}).

2.2 Data sources

As part of this study, test cycle data sources were reviewed to assess the occurrence conditions relevant for high emission or high noise events. Most test cycle data include speed, acceleration and sometimes GPS position, but seldom engine speed however.

Besides data from the literature review, test cycle data was also provided by some LENS partners, which is described below.

HS DAC data

Multiple datasets were provided by HS DAC, containing the following real-world driving data:

- A set of 3 vehicles on one route with different drivers over 28 trips (1965 km in total), collected for the German Environment Agency in a project to study noise reductions on motorcycles, measured in 1998 [17]
- An in-use database with 52 different vehicles (26,000 km in total) driven in various real-world conditions in the EU, USA and in Japan. These data were collected for the purpose of developing the WMTC in 2004 [20]

Multiple datasets were provided by HS DAC, containing the following noise emissions on the test track:

- A set of 4 vehicles, some with standard and modified exhaust in up to 6 driving conditions, collected for the German Environment Agency in a project to study noise reductions on motorcycles, measured in 1998 [17]
- A set of 5 vehicles in up to 5 different driving conditions, with up to 3 different replacement exhaust systems, both legal and illegal systems. These data were collected in a project for the German Environment Agency in 2006 to determine noise emission levels for a selection of replacement silencers for Motorcycles [19]

TNO data

A dataset was provided by TNO from the “Effect study of the environmental step Euro 5 for L-category vehicles” [31]. This study was conducted in 2016/2017 by LAT, EMISIA, TNO and Heinz Steven. Basic emissions-related information was collected by means of tests conducted in different environments



over a large number of vehicles. In total, 44 vehicles were measured on the chassis dynamometer of DG JRC and one vehicle at LAT, 7 vehicles were measured on the road using Portable Emissions Measurement Systems (PEMS) at TNO and DG JRC.

As mentioned above, noise data from roadside measurements in Dutch cities was also made available, from which conclusions could be drawn on the rpm behaviour during loud events of L-vehicles (and cars).

BMW data

A dataset provided by BMW, containing pollutant emission testing data at the chassis dynamometer which was collected for the series development purposes. It contains WMTC data and another internal real-world driving cycle for 5 different motorcycles. The data was measured in 2022. All tests were done at a temperature of 20°C.

KTM data

A dataset was provided by KTM Forschungs und Entwicklungs GmbH, containing on-road measured data for the purpose of durability testing on one vehicle (KTM 390 Adventure MY20). During the trips, fuel consumption, speed, engine speed, gear selection and ambient conditions were measured. The data was collected in Austria in 2020. The vehicle was driven on two different routes which were driven with repetitions. The total mileage is 185 km, the routes cover urban, rural and motorway driving conditions.

Piaggio data

A dataset was provided by Piaggio, containing on-road measured data for the purpose of durability testing on one vehicle (Vespa GTS 300cc). ECU data was collected during the trips on urban and extra-urban road types. The data was collected in 2022 in Tuscany, Italy.

IFPEN data

IFP Energies Nouvelles has collected large-scale mobility data in real usage driven by non-professionals users through a proper application Geco Air available since 2017 [46]. This application is dedicated to better understand mobility and to offer to the user services such as personalized ecological impact advice to reduce their own mobility footprint. The database is collected for research purposes, aiming to better understand the real use of vehicles: driving behaviour and road conditions. The database is composed, on the one hand, by the main characteristics of the vehicle from engine, transmission and body extracted from its license plate number. On the other hand, it is composed by one-second GPS time-series (speed and coordinates) completed by the map-matching information (limit speed and elevation); each trip is checked by a data cleaning step to verify the good quality of the time-series.

For this case, the analysed database consists of the trips driven by a motorcycle where the license plate number is known, and the accuracy has been validated and the information has been map-matched to retrieve supplementary information; given a sample of 2214 trips driven by 72 users.



Ducati data

A dataset was provided by Ducati, containing pollutant emission testing data at the chassis dynamometer for the WMTC and four different vehicles with engine capacities between 936 cm³ and 1266 cm³. In addition, the stationary sound emission test results were provided. The data was collected in Italy in 2021.

IDIADA data

The IDIADA data consists of 3 vehicles (characterised as small, middle and big), 3 road types (urban, rural, highway) with 2 to 5 trips per vehicle road type combination. Total usable distance 3034 km, total duration 42.6 h. GPS data was monitored, vehicle speed was derived from GPS data with 10 Hz sample rate.

2.3 Comparison of the datasets

By far the largest sets of in-use data were provided by IFPEN and HS DAC. The IFPEN data consists of 72 different vehicles (2 electric scooters and 70 ICE vehicles with engine capacity between 124 cm³ and 1293 cm³ and rated power values between 8 kW and 118 kW). Vehicle speed, speed limit and altitude were monitored with 1 Hz sample rate. 4 vehicles were disregarded for further analysis because of too low monitoring times and distances. The others have mileages between 10 km and 3460 km (average 397 km) and average speeds of 16 km/h to 71 km/h. The data was collected in France. Although one important parameter (engine speed) is missing, the IFPEN data is of high importance because it is all customer data, and has information on the slope.

The database for the development of the WMTC consists of 52 vehicles and was collected in the EU, US and Japan during dedicated measurement campaigns. Vehicle speed, engine speed and road category information was measured/monitored but information about the altitude (and the resulting road slope) is missing. The engine capacities range from 49 cm³ to 1520 cm³, the rated power values from 4 to 112 kW and the rated engine speeds from 4500 min⁻¹ to 12500 min⁻¹.

The average speed per vehicle/trip combination in the IFPEN database range from 2.6 km/h up to 130 km/h, The overall average speed is 46.1 km/h. The stop percentages range from 0% to 65.2%. The corresponding values for the EU part of the WMTC database are average speeds ranging from 35.2 km/h to 78.8 km/h. The overall average speed of the EU WMTC data is 53,3 km/h. The stop percentages range from 0.9% to 20.7%.

Compared to the IFPEN data the ranges for average speeds and stop percentages are narrower in the EU WMTC data but the overall average speed is higher. 5% of the trips in the IFPEN database have average speeds below 12 km/h and thus represent stop and go conditions only. This is not the case for the WMTC database although stop and go conditions occurred within some trips.

The data in both datasets (IFPEN and WMTC) is separated into different trips per vehicle. In the IFPEN dataset the trips are called "routes" in the WMTC dataset they are called "cycles". In the following figures distributions of different parameters are compared. For the WMTC dataset it is differentiated between all regions and the EU part only. Corresponding distributions from the WLTP in-use database for cars and N1 vehicles (EU part only) are shown for comparison.



Figure 2-5 shows the trip distance distributions of the different datasets. The IFPEN distribution is close to the EU-WLTP distribution for cars. Both datasets are customer data and short trip distances have a much higher share than for the WMTC data whose distributions reflect the typical structure of predefined routes of measurement campaigns. Compared to customer data short distance trips are underrepresented.

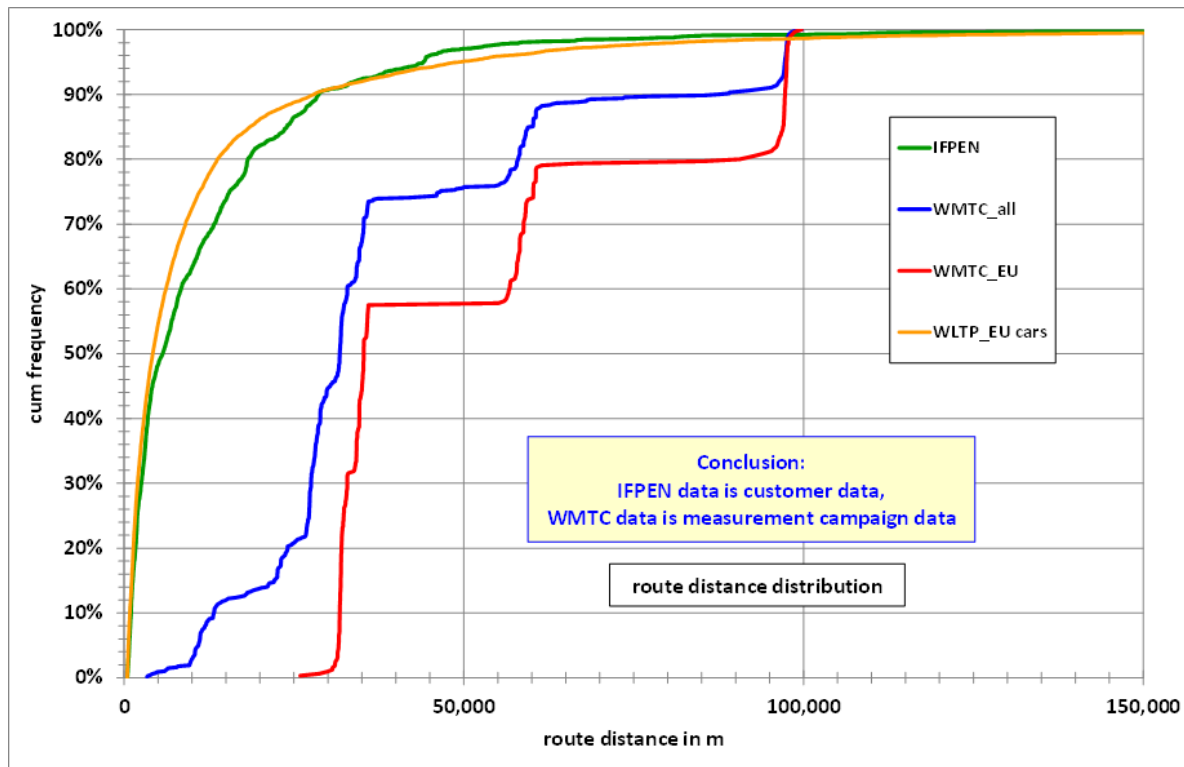

Figure 2-5: Trip or route distance distributions for the different L-category vehicles datasets

Figure 2-6 and Figure 2-7 show the distributions of average and maximum speed values per trip. The following conclusions can be drawn: The IFPEN data contains a wider spread of traffic situations in terms of traffic load (more saturated and congested traffic) than the WMTC data while the percentages of rural and motorway traffic are higher in the WMTC data compared to the IFPEN data.

For a more specific comparison the data for both datasets were split into 4 different vehicle classes with respect to rated power or engine capacity classes:

1. Up to 150 cm³ engine capacity,
2. > 150 cm³, rated power between 18 kW and 35 kW,
3. > 150 cm³, rated power between 40 kW and 64 kW,
4. > 150 cm³, rated power between 70 kW and 118 kW.

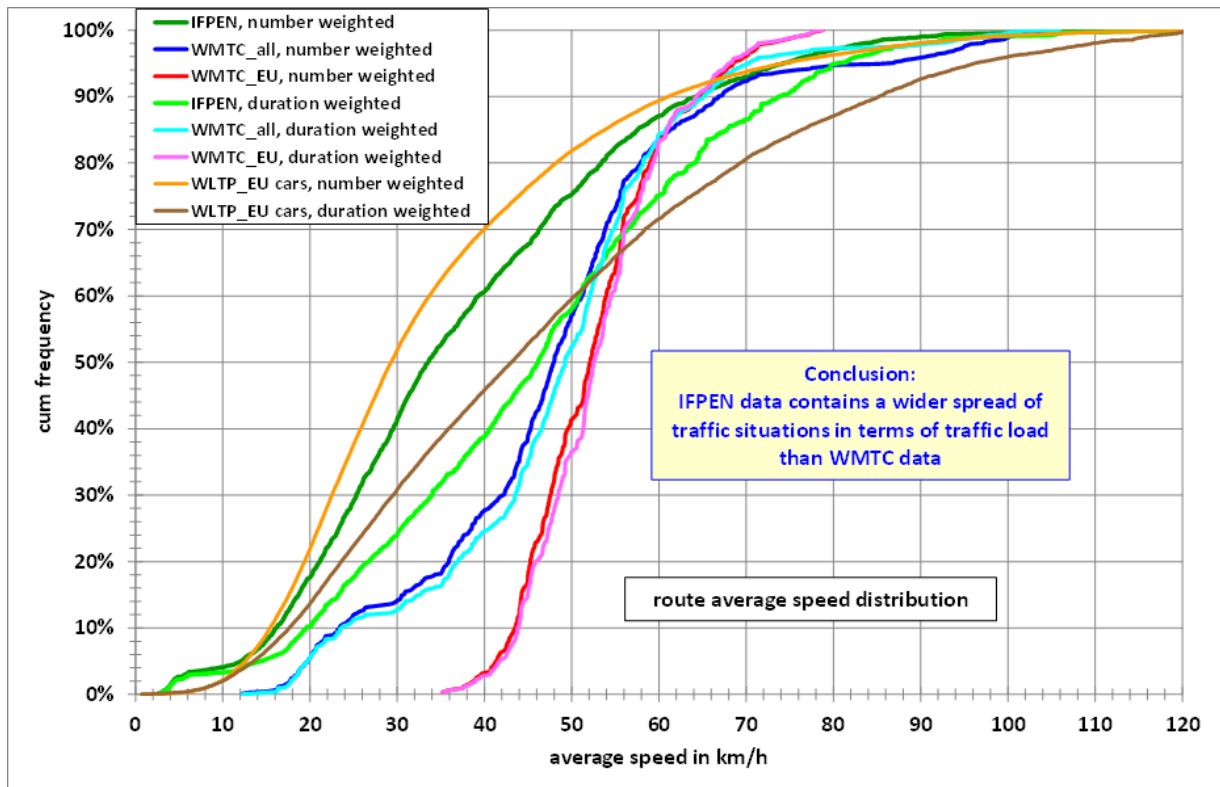

Figure 2-6: Distributions of average speed values per trip

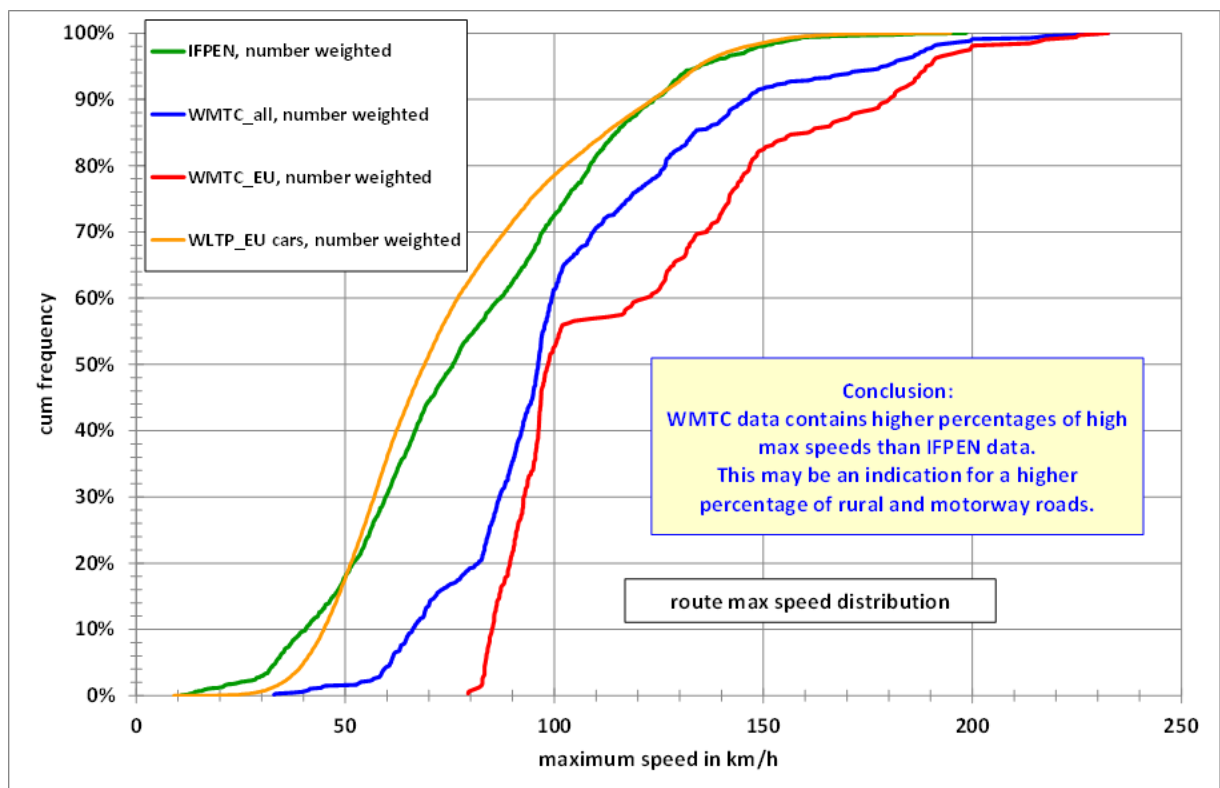

Figure 2-7: Distributions of maximum speed values per trip



Figure 2-8 shows the vehicle speed distributions for the two datasets and the four vehicle classes. The highest differences between the IFPEN and the WMTC datasets are related to scooters and low powered motorcycles.

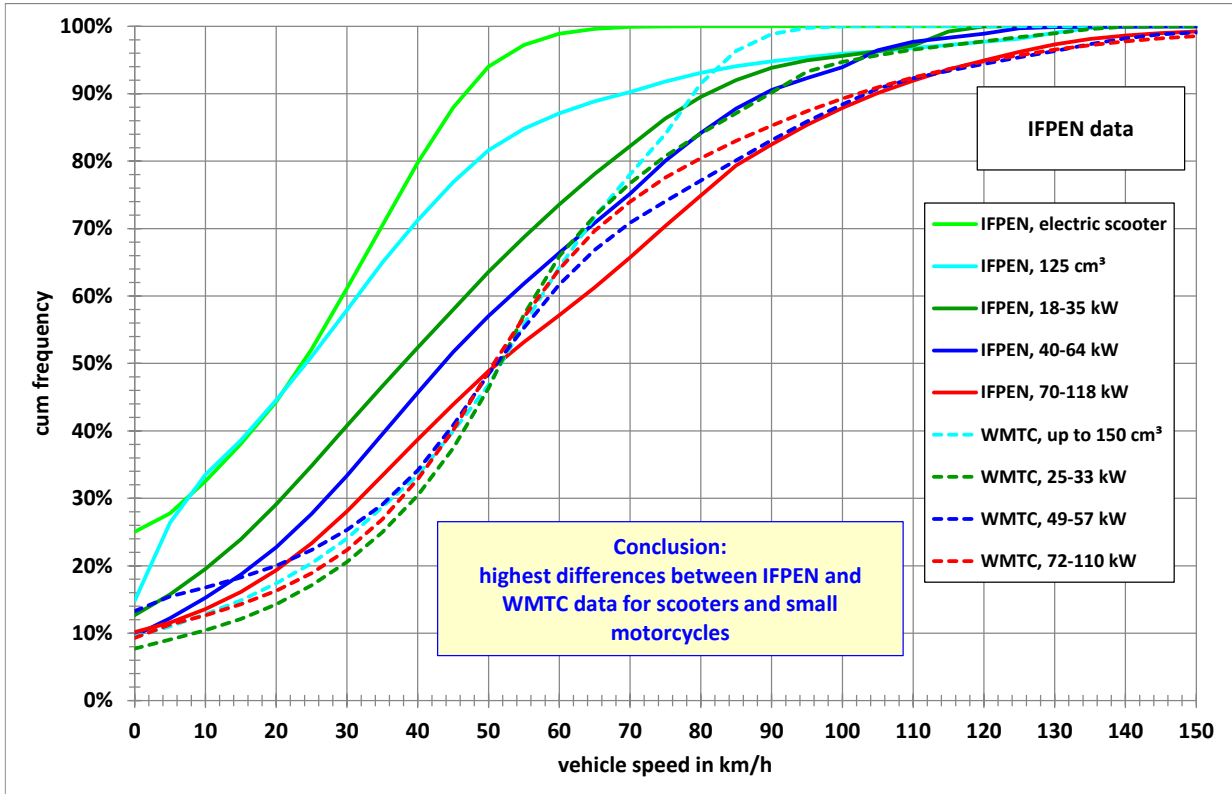

Figure 2-8: Distributions of vehicle speeds for the different vehicle classes as specified above

Figure 2-9 and Figure 2-10 show the acceleration distributions for the two datasets and the four vehicle classes for two vehicle speed bins (around 30 km/h and 70 km/h). For both vehicle speeds the WMTC vehicles were driven more dynamic than the IFPEN vehicles. This is not necessarily caused by different driving behaviour; it could more likely be caused by differences in the traffic load situations.

For the WMTC vehicles the differences between the vehicle classes are more pronounced for 70 km/h than for 30 km/h. This is caused by the higher power demand at 70 km/h compared to 30 km/h.

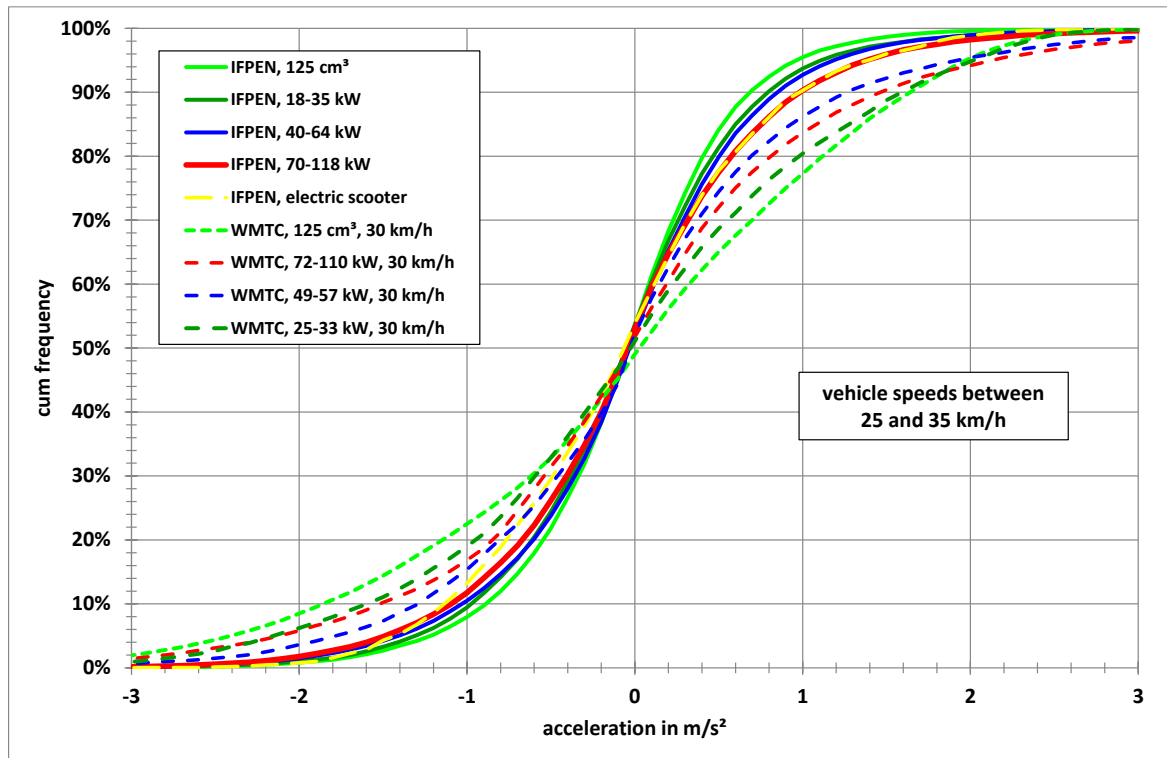

Figure 2-9: Distributions of acceleration values at vehicle speeds around 30 km/h for the different vehicle classes as specified above

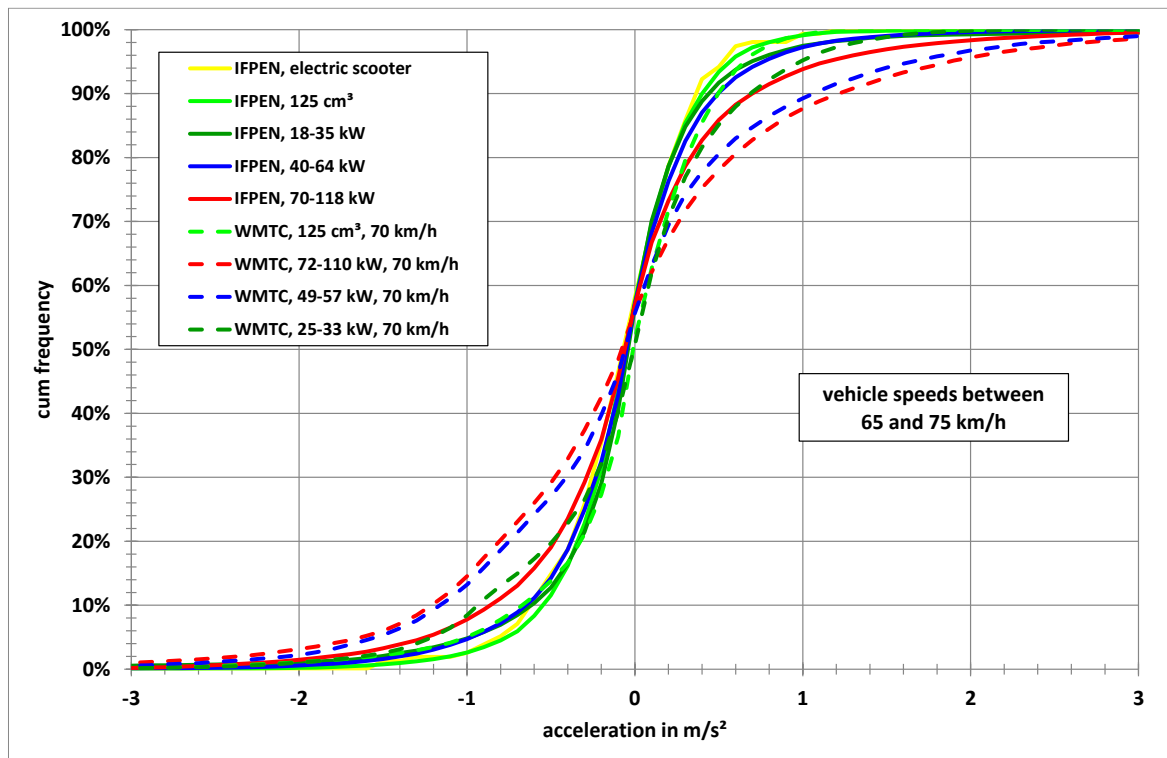

Figure 2-10: Distributions of acceleration values at vehicle speeds around 70 km/h for the different vehicle classes as specified above



The results of the comparison can be summarized as follows:

The IFPEN data has a higher variation range in terms of traffic situations than the WMTC data, but since the engine speed as the most significant noise influencing parameter is missing in the IFPEN data, both datasets are necessary for the determination of noisy driving/operation conditions as well as high exhaust emissions conditions, and their frequency shares in real world operation.

Another notable difference between the WMTC and IFPEN databases is the availability of instantaneous slope (or elevation) information, available only in the IFPEN database.

An analysis is presented below to quantify the impact of slope on driving conditions. In the absence of emission and noise measurements, this analysis is based on an estimate of the energy consumption.

It should also be noted that a pre-processing step of the raw altitude data collected by GNSS, called map-matching, is essential and is performed on the IFPEN dataset.

Influence of road slope

As the data that comprise the IFPEN database are solely gathered from drivers in real world situations, there is a multitude of routes and trips, as explained above, and thus there are varying geomorphological characteristics that may affect the driving behaviour and consequently the operating point of the vehicle's engine.

The purpose of this study on the IFPEN database is to investigate the magnitude of the effect that the slope has on the cumulated energy at the wheel and on the engine's operating points, throughout all the trips. This way, the criticality of including slope variations in the testing phase can be showcased.

To be able to provide an indication of the slope's effect, it is important to create a simple longitudinal vehicle dynamics model of the vehicle. As each vehicle's mass and nominal power are known, with a simple zero-dimension (0D) model we can derive indicating factors of the slope's overall effect in terms of energy consumption. The 0D model treats the vehicle and its payload as a singular point that concentrates all the mass, where all the efforts relative to the vehicle's motion are exercised.

The way the instantaneous and cumulated energies on the wheel are calculated can be described with the following equations:

$$F_{(wheel,N)} = m_{veh} * \alpha + C_{veh} * v^2 + A_{veh} * \cos(slope) + m_{veh} * g * \sin(slope)$$

where $C_{veh} = f(m_{veh})$

and $A_{veh} = f(m_{veh})$

$$E_{(wheel,kWh,inst)} = F_{(wheel,N)} * v * dt / 3600000$$

$$E_{(wheel, \frac{kWh}{100km}, cumulative)} = \frac{\sum_{i=1}^{total\ trips} \sum_{t=0}^{trip\ duration} E_{(wheel,kWh,inst)}}{\sum_{i=1}^{total\ trips} \sum_{t=0}^{trip\ duration} distance} * 100$$



Where m_{veh} is the mass of the vehicle adjusted by adding an additional 80 kg for the driver, a the vehicle's acceleration and v the vehicle's speed. Rolling resistance and air resistance coefficients A_{veh} and C_{veh} are calculated using the corresponding table in (Regulation (EU) No 134/2014, 2014) (Regulation (EU) No 134/2014, 2014).

Knowing the force on the wheel and the vehicle's speed the calculation of the power on the wheel can be derived as $P_{wheel,kW} = F_{wheel,N} * v/1000$. Then, by assuming a constant gearbox efficiency throughout the vehicles and trips, a notion of instantaneous power ratio can be obtained by dividing by the nominal power of the engine of each vehicle as shown below:

$$P_{(mot,kW)} = P_{(wheel,kW)}/\eta_{gearbox}$$

where $\eta_{gearbox} = 0.85$

$$PowerRatio = P_{(mot,kW)}/P_{nom} * 100$$

$$\text{if } P_{(wheel,kW)} < 0 \rightarrow PowerRatio = 0$$

As a reiteration, the above calculation does not provide the exact engine load percentage but rather an indication of how strenuous the driving conditions are on the engine as a type of power ratio against the vehicle's nominal power. In order to properly gauge the slope's effect on the energy consumption all the above calculations have been duplicated, while imposing a constant slope of 0 throughout all the trips to eliminate its effect on the resistive force calculation.

In addition to the baseline study, two complementary studies were carried out, one keeping the top 10% of trips that are most severe in terms of slope, and one considering a second passenger to add to the payload of the vehicle. The following figures summarize the findings.



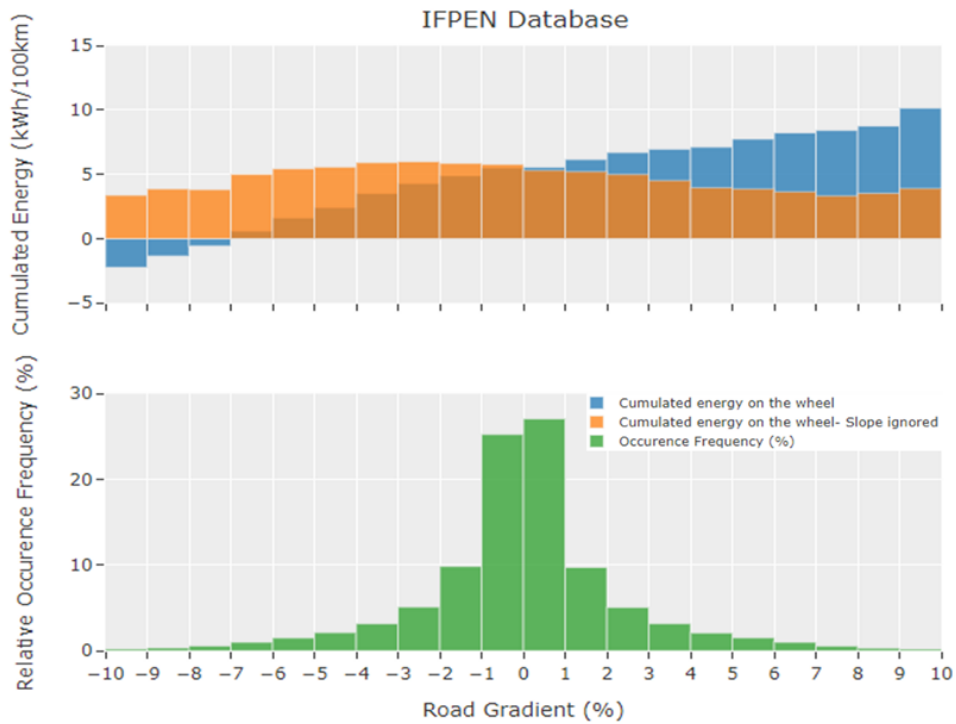

Figure 2-11: Specific cumulative energy on the wheel binned by road gradient and relative occurrence frequency of each road gradient bin – IFPEN Database

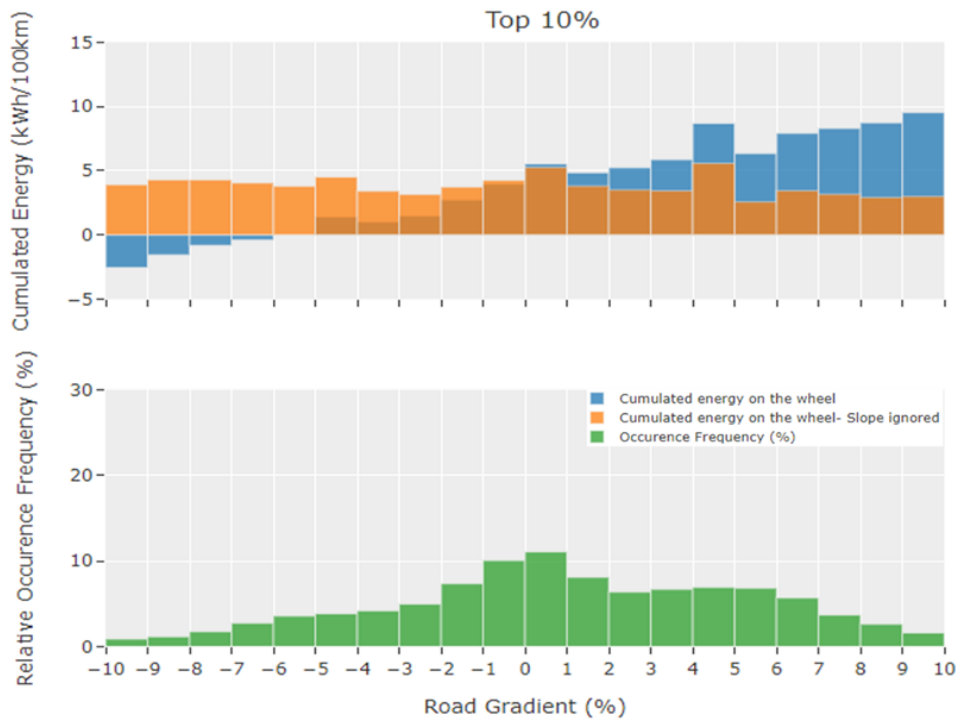

Figure 2-12: Specific cumulative energy on the wheel binned by road gradient and relative occurrence frequency of each road gradient bin – Top 10% most severe trips in terms of ascending slope



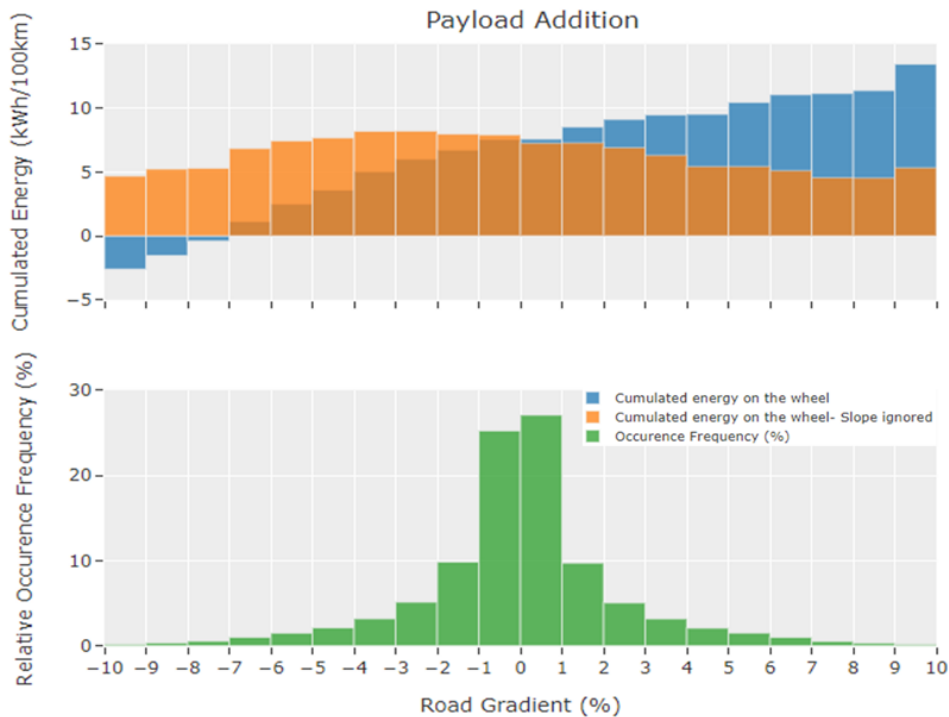

Figure 2-13: Specific cumulative energy on the wheel binned by road gradient and relative occurrence frequency of each road gradient bin – Payload addition (second passenger)

Figure 2-11, Figure 2-12 and Figure 2-13 show the specific cumulative energy distribution on the wheel binned by road gradient as well as the relative occurrence frequency of each bin, for the 3 case studies: the whole of the IFPEN database, the top 10% of most severe trips with regards to ascending slope in the database and the whole of the IFPEN database when taking into account two passengers per vehicle instead of one. By definition, Figure 2-12 that corresponds to the most severe trips shows a different distribution of road gradients compared to the other two figures. On the other hand, Figure 2-13 shows higher values of specific cumulative energy on the wheel, which is to be expected in this case when considering two passengers in our model. These figures provide an overview of the data analysed from the IFPEN database but fail to provide a straightforward answer to the effect that the slope has on the energy consumption of the vehicle. There is a pronounced absolute effect on the higher road gradient bins, but as the relative occurrence frequencies graphs show, these conditions are seldom met, particularly when looking at the whole database.

To attempt a clearer visualization of the effect of the slope, the instantaneous power ratio probability distribution is introduced in Figure 2-14. Essentially, this graph provides the probability to exceed a given value of instantaneous power ratio (IPR). For example, for the value of 20% of IPR in the Payload addition case with the slopes included (blue dotted line) there is an, approximately, 20% probability of



encountering ratios higher than this value. The interest of such a representation, complementary to the classical cumulative frequencies (or S-curve) is to focus the analysis on the critical cases, in other words the last few percentiles of the data (in particular thanks to the logarithmic scale on the ordinate). We can thus read the power ratio which is reached only in 10%, 1% or even 1‰ of the cases. This figure gives the probability $P_c(X > IPR)$ meaning that when $IPR \leq 0$ (braking and stop phases) this will translate in a vertical line at $IPR = 0\%$. For all the cases studied in the premises of this report the braking and stop phases correspond to roughly 25% of all occurrences.

This figure showcases the lack of effect of the slope when considering the whole of the database (continuous and dotted lines) and the existence of such an effect when handpicking a part of the database where this parameter is more noticeable (dashed lines). To further illustrate this point, we can assume a vertical line at 40% IPR. This line cuts the six different curves in different points. Comparing the blue and orange lines by dash type we observe that only the dashed lines have a wide gap between them. For the 40% IPR example, when ignoring the slope (orange dashed line) we find a probability of less than 2% to encounter IPR values higher than that. On the contrary, when the slope is taken into account (blue dashed line) the probability to encounter higher loads increases to almost 4%, meaning that when we ignore the slope effect the power ratios calculated are smaller and consequently the energy consumed is less. However, this effect is pronounced only for the top 10% of the trips based on the ascending slope. For the dotted and continuous lines, the differences between blue (slope included) and orange (slope ignored) lines are minimal. This leads to the conclusion that while there is an expected effect of slope in energy consumption, particularly in roads with high grade variation, when considering all the trips in the IFPEN database this effect becomes less visible as most trips in real world driving conditions occur in small road grades. When looking at the additional payload curves (dotted lines) no significant effect of the slope occurs, as is the case for the baseline study (continuous lines), but the curves are translated further to the right meaning that the power ratios encountered in this case are higher and thus the energy consumed increases as well. It has to be said that higher energy consumption is frequently associated with higher pollutant emissions and the higher power ratios could potentially lead to higher noise emissions.

To conclude, when looking at the whole of the IFPEN database it's hard to spot the effect that the slope has in energy consumption as the high gradient parts of the different registered trips represent a very small percentage overall. The effect becomes pronounced when excluding 90% of the trips and analysing only the 10% that provide the worst conditions in terms of ascending slope. Finally, adding to the payload yields no effect with regards to the slope but higher energy consumption overall is observed. The above prove the dependence of the result of the analysis on the road characteristics of the trips in the database, rather than on the assumptions made in terms of payload in the OD model.



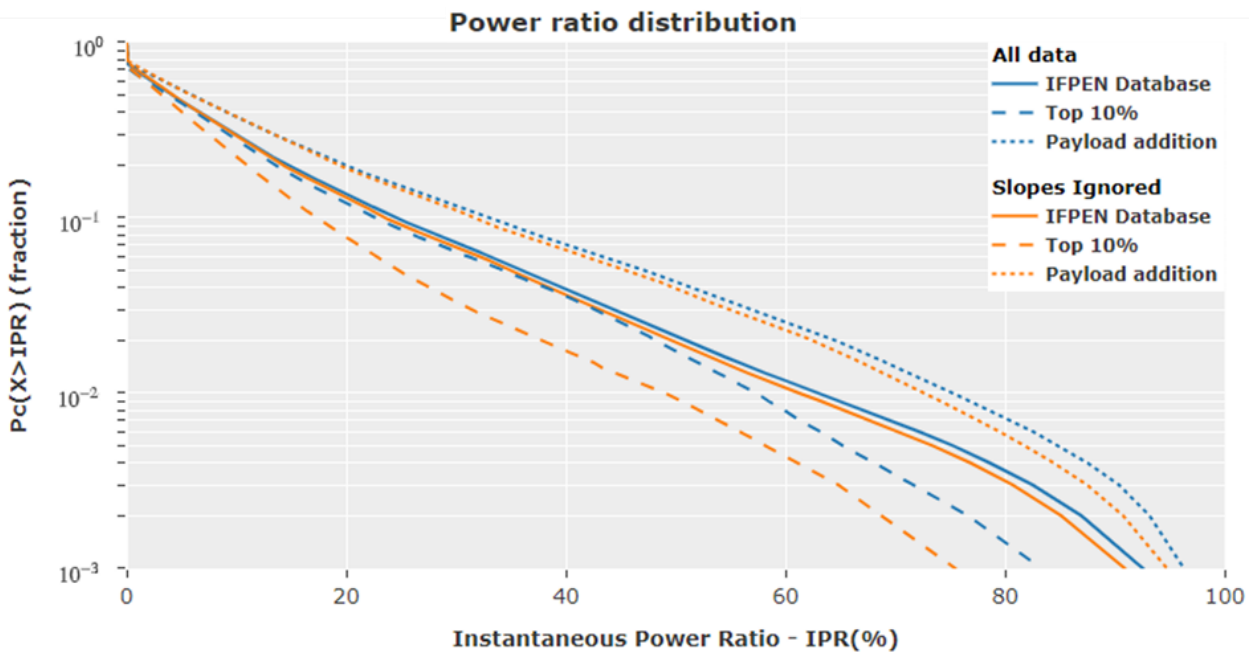

Figure 2-14: Instantaneous power ratio probability distribution

2.4 Assessment of critical driving conditions for pollutant emissions

The most relevant parameters for high noise emissions are high engine speed, vehicle- and engine speed acceleration, and increased load. Moreover, for pollutant emissions, the cold (engine) start phase and – for mopeds – driving at maximum speed is very relevant. This was shown in Table 2.1. In the following sections it is analysed in further detail whether these driving conditions which cause high noise emissions also lead to elevated pollutant emissions. For this purpose, the datasets listed in Section 2.2 was analysed.

2.4.1 Approach

The purpose of the assessment is to extract driving conditions that lead to high noise and/or pollutant emissions. In an ideal situation, data would be available containing measured emissions on the road. High emission events would be filtered out and the corresponding driving situations could be further analysed for the frequency of occurrence in real-life. However, in reality there is only scarce data available where emissions (either noise or pollutants) are measured on the road. Datasets collected for this project mainly consist of:

- Pollutant emissions measured over driving cycles in the laboratory
- Noise emissions measured in a drive-by situation on the test track
- In-use driving data of vehicles driven on the road (mostly without emissions being measured, only vehicle parameters)

A small number of PEMS tests with L-category vehicles were available. However, this was an experimental test campaign, and therefore the results can only be considered indicative.



Due to the lack of sufficient on-road emission measurements, an alternative approach had to be developed.

This alternative came from the awareness of the following aspects:

- There is a relatively good understanding of which driving conditions lead to high emissions (in particular for noise emissions and to some degree for pollutants);
- These conditions are mostly related to high vehicle speeds and accelerations, high engine load and high engine speeds and accelerations, and cold start events;
- It is assumed that the driving situations that lead to high noise emissions largely overlap with the driving situations leading to high pollutant emissions. The only exception concerns pollutant emissions for cold start events.
- By using the available test data, the above-mentioned aspects will be validated

From these points it was concluded that the best approach was to reverse the assessment: rather than analysing the data for high emission events from which the critical driving situations are extracted, the idea is to assume a set of driving conditions for which high pollutant emissions are expected and analyse the on-road driving data for the occurrence of such conditions. In parallel, the pollutant emissions measured in the laboratory need to be analysed to find out the emission levels for these driving situations. This will show to which extent these driving conditions also lead to high pollutant emissions, or if there are more driving situations that need to be included. In Section 0 this will be analysed in detail.

This approach requires that these critical driving conditions be parametrized in order to be filtered from the on-road data, which will be further addressed in Section 2.6. The set of critical conditions described in Table 2.1 is used as a basis for the assessment (including the cold engine start).

2.4.2 Analysis of pollutant emissions for critical driving situations

In order to confirm the assumptions about which driving conditions pose critical events with respect to pollutant emissions, the results of chassis dyno tests were analysed. The questions to be answered is:

- *What are the critical driving conditions, i.e., under which conditions are the pollutant emissions of L-category vehicles the highest?*
- *How big is the contribution of the emissions during critical events to the overall emissions of a vehicle?*
- *Do the high emissions events with respect to pollutants correspond to the high noise events defined in Table 2.1?*

Test results of 30 vehicles were analysed in order to examine this. Of these, 26 data sets originated from the Effect study of the environmental step Euro 5 for L-category-vehicles [31] and four were contributed by Ducati. The number of available test results per vehicle varies significantly. For some, only a single test file was available, whereas for others many driving cycles could be studied. The test types included the standard WMTC, UN ECE R 40 and UN ECE R47 tests but also tailored experimental setups like Wide-Open-Throttle tests or experiments where it was tried to reproduce real-



world driving emissions on the chassis dyno. In total, 565 result files were studied. The processing of 330 of them yielded results that were used for further

analysis in the LENS project. The reasons for excluding tests were missing information and lack of measured quantities. Also, for some tests, two result files containing the same data were available of which, of course, only one was taken into account. A few files were corrupted and could not be opened.

The results of all tests were made available in the same format as .xls files. From these files the below data was taken:

- Vehicle data:
 - Vehicle test mass; and
 - Road load factors f_0 , f_1 and f_2 .
- Measured timeseries:
 - Sample time;
 - Vehicle speed;
 - Air-fuel equivalence ratio λ ;
 - Post-catalyst concentration per pollutant in [ppm];
 - Post-catalyst mass emission per pollutant in [g/s]; and
 - Exhaust flow rate in [m³/s].
- Additional information about the test, such as driven distance, acceleration and vehicle power, was derived from this input.

Since engine operation at cold conditions ("cold start") is known to produce elevated levels of pollutant emission, the tests were split up into a cold and a warm part. For the WMTC, UN ECE R 40 and UN ECE R47 test cycles this was done based on the definition of the cold and warm phases stated in Commission Delegated Regulation (EU) No 134/2014 (as amended by Commission Delegated Regulation (EU) 2018/295). For non-standard tests, the data was split as follows:

- If the oil temperature at the beginning of the test was less than 40°C, the start of the warm phase was defined as the test time when it reached this threshold for the first time.
- In cases where the oil temperature was not measured but data on the temperature of the exhaust gas was available, a threshold of 170°C was used.
- If based on the conditions mentioned above the cold phase was less than 60 seconds, the whole test was considered as "warm" and therefore the data was not split into cold and warm phases.

The outcome of the analysis will be discussed in the following, based on two example vehicles. One is a two-wheel moped (L1e-B) with emission class Euro 2, the other is a Euro 4 two-wheel motorcycle (L3e-A3). Five different types of plots are used. There may be more than one figure per plot type if different pollutants are discussed. The plot types are:

- Overview of tests per vehicle
 - Overview of instantaneous test results plotted together for speed trace (Figure 2-15 & Figure 2-20).
- Type-approval test:
 - Emissions map of total test (Figure 2-16 & Figure 2-21);



- Emissions map of cold part (Figure 2-17 & Figure 2-22); and
- Emissions map of warm part (Figure 2-18 & Figure 2-23).
- Results of combined tests:
 - Emissions map of all test data combined (Figure 2-19).

On the abscissa of emission maps the vehicle speed in m/s is plotted whilst the ordinate shows the positive acceleration in m/s^2 . Grey contour lines refer to the parameter $v \cdot a_{\text{pos}}$ as an indicator of the driving dynamics. The coloured contour lines indicate the vehicle's power demand at a given combination of speed and (positive) acceleration. It is related to $v \cdot a_{\text{pos}}$ via the acceleration power but also takes the road load into account. Finally, the instantaneous emissions, grouped into speed/acceleration bins, are depicted as color-coded dots. The associated value of the colour levels is indicated by the colour bar at the right of the images. Every dot consists of three rings. The colour of the inner ring indicates the 10th percentile of the instantaneous emission level, the outer the 90th percentile and the middle is the mean level. The differences in colour between the rings gives an indication of the scatter of measured values in the bin. The size (area) of the dots is scaled to their contribution to the total mass emission. The dot size does not have an absolute interpretation, it can only be used to compare the mass emissions of two bins of one plot to each other.

The results in this section are only shown for nitrogen oxide emissions (NO_x). For other emission components the results can be found in Annex C and will be addressed qualitatively in this section.

Pollutant emission data of three mopeds measured with a Micro PEMS is also summarized in Annex C. Different to chassis dyno data, the data points are spread over the whole range of possible combinations of speed and acceleration. Similar to the chassis dyno results, high emissions occur at combinations of high speed and high power. However, it was an experimental test campaign, and therefore the results can only be considered indicative.

Moped results

Figure 2-15 shows the instantaneous NO_x mass emissions of nitrogen oxides of a moped together with the speed trace for three different types of test: a Wide-Open-Throttle (WOT) test, WMTC stage 1 and UN ECE R47. For all three tests, the NO_x emissions are the highest during phases of acceleration, i.e., a rising speed trace. This is in particular the case for accelerations with wide-open throttle. Deceleration and driving at constant speed yield significantly lower instantaneous emissions.



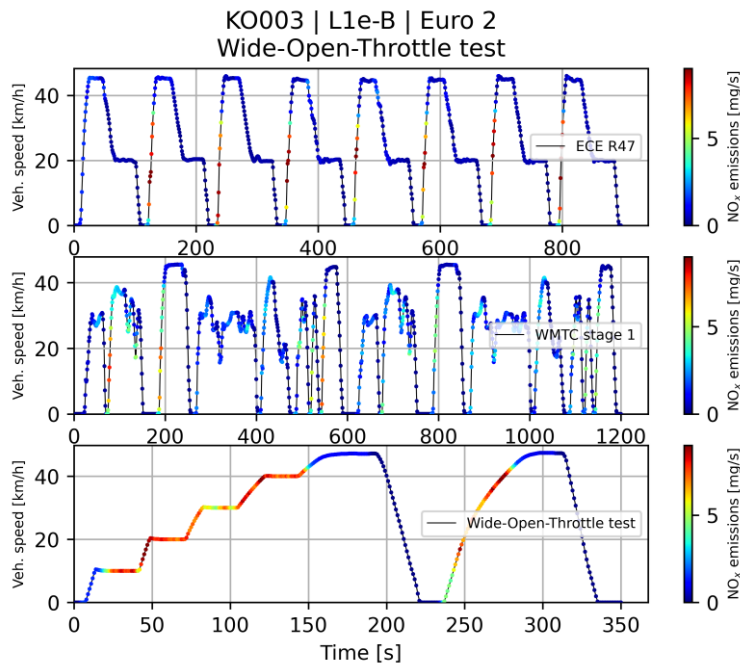

Figure 2-15: Instantaneous NO_x mass emission of different tests

In the following the results of the type-approval test of the moped, the UN ECE R47, are discussed. Figure 2-16 shows the NO_x emission map of a UN ECE R47 test cycle. The three constant speed levels of the UN ECE R47 cycle at standstill, 20 km/h (5.6 m/s) and maximum speed of approximately 45 km/h (12.5 m/s) can be clearly identified on the x-axis. Between these speeds there is acceleration with full throttle which leads to dots along the maximum power line. At high speeds the instantaneous NO_x mass emissions become lower. For lower speeds, maximum power is not available. Therefore, there are some dots in bins of low speed and varied acceleration. The emissions during acceleration are consistently high, with low spread, i.e., the colour levels of the rings of a dot are almost identical. The contribution of single bins is the highest for the constant speed bins and one bin with low speed and low acceleration. This is, however, partially caused by the large time share of these bins compared to bins which are run through very fast during acceleration. So, it could be argued if the ECE R47 driving cycle is a good representation of real-world driving behaviour.



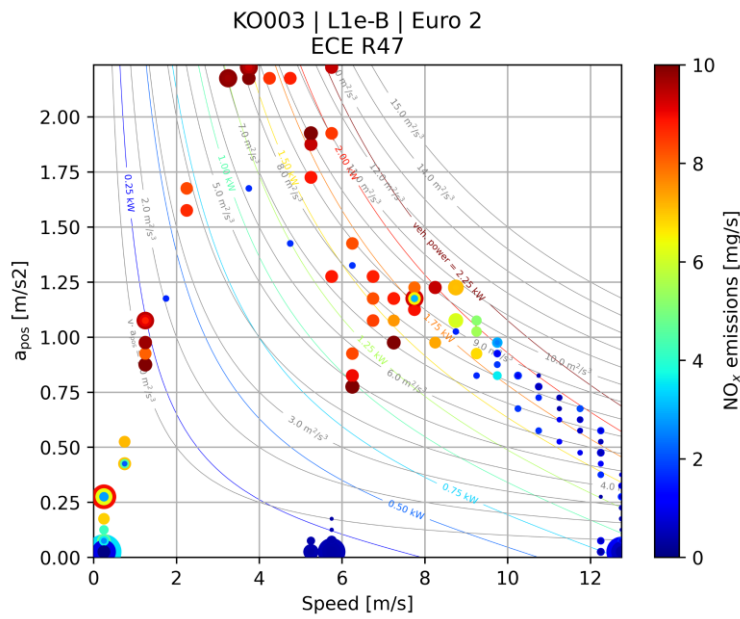

Figure 2-16: NO_x emission map of a moped on the UN ECE R47 cycle

The NO_x mass emissions in the cold phase the ECE R47 are depicted in Figure 2-17. The interpretation of the plotted data is similar to what has been said about the full test before. That is no surprise because the cold phase of the ECE R47 consists of the first four of a total of eight repetitions of the same speed pattern. An elevated level of NO_x emissions for the cold start phase is not clearly visible.

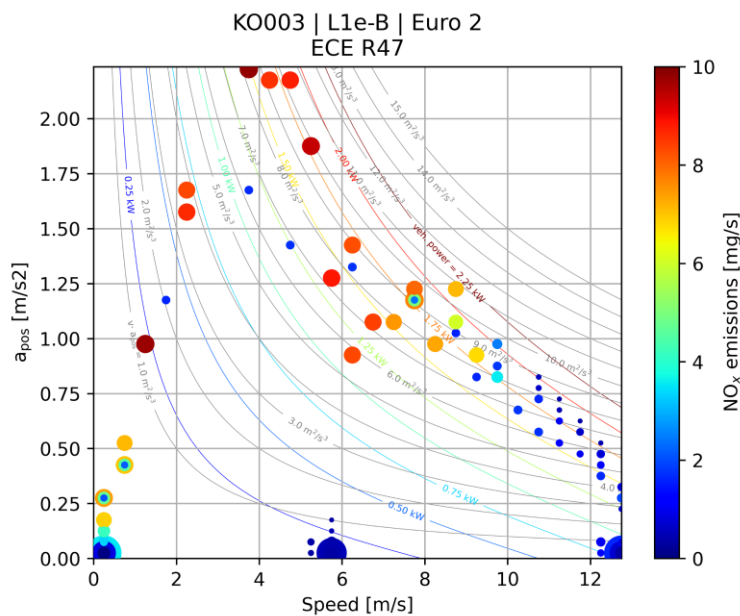

Figure 2-17: NO_x emission map of a moped on the UN ECE R47 cycle (cold start phase)



The warm phase of the ECE R47 is depicted in Figure 2-18. The plotted data covers the second half of the ECE R47 test, i.e., the 5th to the 8th repetition of the pattern. For the location and the size of the dots the same statements as already made for the total test and the cold phase apply.

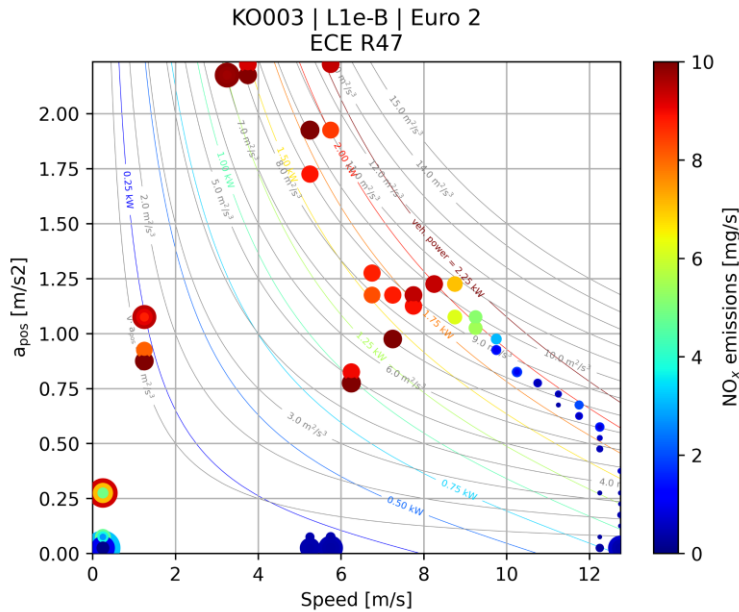

Figure 2-18: NO_x emission map of a moped on the UN ECE R47 cycle (warm start phase)

After focusing on the results of one test, the combined dataset of all available results for the moped will be discussed in the following, starting with Figure 2-19. This plot shows the NO_x emission map. As expected, the distribution of the dots is not as distinct as it is for the ECE R47 cycle. There are samples in many more bins and the only constant speed bin with a high share of total NO emissions is at standstill. High mass emissions of NO_x occur under many combinations of speed and acceleration, with significant spread in some bins. Emissions are high during acceleration from standstill and at high accelerations.



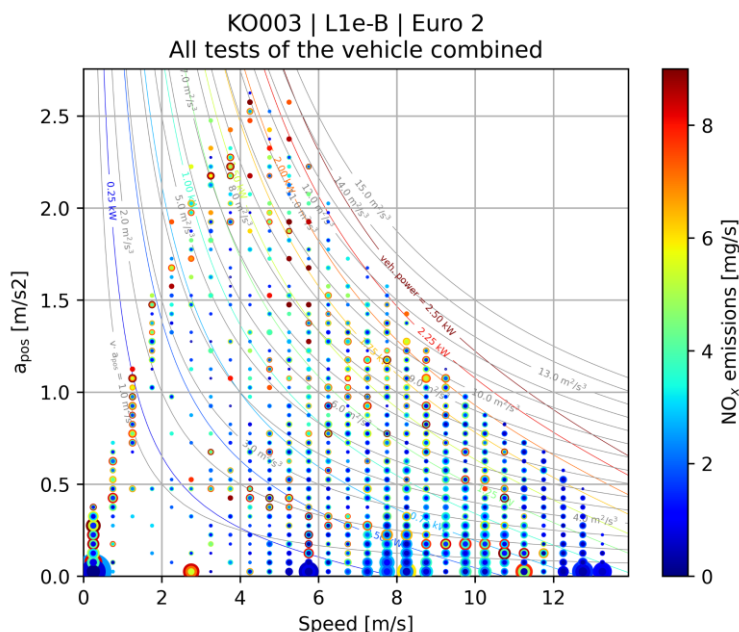

Figure 2-19: Combined NO_x emission map of a moped

Besides NO_x, also the emission of unburnt hydrocarbons, carbon monoxide and particles pose relevant threats to human health and the environment. Therefore, these have also been analysed for this study. Plots of the same kind as used for NO_x depicting the data measured for (some of) these pollutants can be found in Annex C for the moped and the motorcycle, respectively. The instantaneous mass emissions of carbon monoxide of the moped are high at high speeds, especially if the vehicle is accelerating. These bins also contribute the largest share of cumulated mass emissions of these compounds for the observed driving cycles. The levels of CO emission are higher in the cold phase of the test compared to the warm phase. The mass emissions of unburnt hydrocarbons are emitted after the throttle is released and the vehicle is decelerating. The measured levels are higher in the cold phase.

Motorcycle results

As the second representative L-category vehicle a motorcycle (L3e-A3) was selected. The discussion of the results follows the same scheme as for the moped, starting with an overview of test types in Figure 2-20. For this vehicle only data from WMTc tests are available for analysis. The mass emissions of nitrogen oxides of one example test are depicted in Figure 2-20 below. High emissions occur during the first acceleration from standstill and at speeds beyond 100 kph.



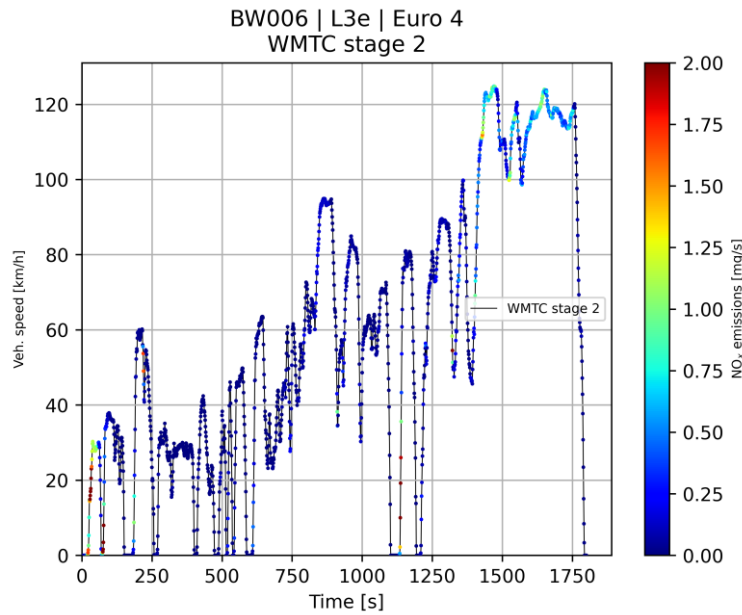

Figure 2-20: Instantaneous NO_x mass emission of the WMTC Stage 2 test

The emission map of one WMTC is plotted in Figure 2-21 below. High instantaneous NO_x emissions occur on the one hand at accelerations from standstill and at low speed. On the other hand, maximum power at maximum (test) speed yields high NO_x mass flows. The scatter of values is higher at conditions of the second type. These two operating conditions are also responsible for the bulk of total NO_x mass emissions. Medium speeds and accelerations/powers do not contribute much – also due to the short time share per bin.

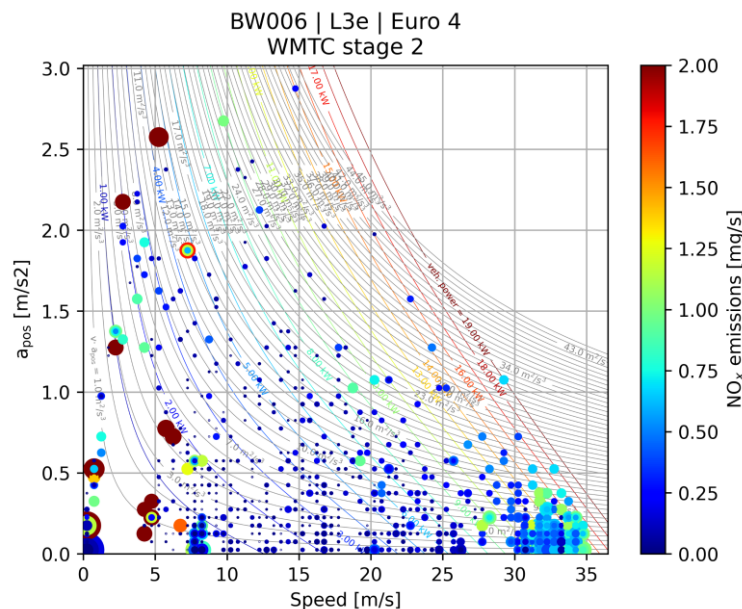

Figure 2-21: NO_x emission map of a motorcycle on the WMTC Stage 2 cycle



The contribution of the cold phase – in case of the WMTC this is the first 600 seconds of the test – is depicted in Figure 2-22. Due to the limited speed and acceleration values in this part of the test, the essential contributions to the total emission of NO_x happen at bins with lower speed/acceleration. Again, high acceleration from standstill and low speed yields high instantaneous emissions but also lower values of acceleration at medium speeds of about 4 to 8 meters per second show high NO_x mass flows.

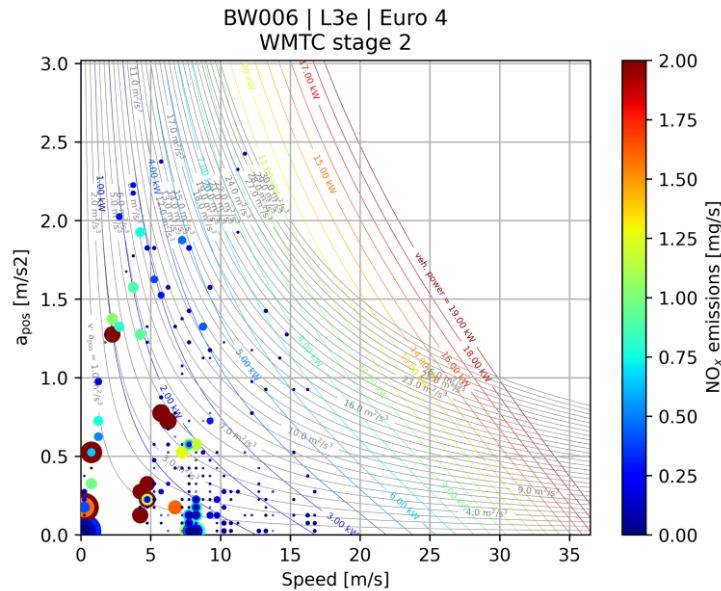

Figure 2-22: NO_x emission map of a motorcycle on the WMTC Stage 2 cycle (cold start phase)

The warm part of the WMTC is depicted in Figure 2-23 below. Here high emission events are clearly at combinations of high power and speed. In addition, acceleration at low speeds also contributes significantly to total NO_x emissions.

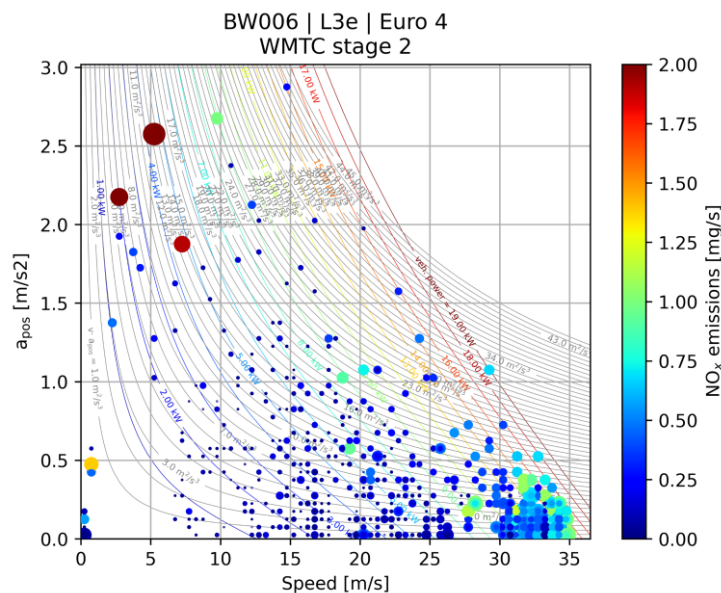

Figure 2-23: NO_x emission map of a motorcycle on the WMTC Stage 2 cycle (warm phase)



Since only WMTC tests were done with this motorcycle, no plot of the combined data of all tests is discussed at this point because the interpretation is the same. Regarding CO, the motorcycle has the highest instantaneous emissions at high speed. Acceleration during the cold phase also yielded high mass flows. For unburnt hydrocarbons the influence of the cold start is even more evident. Different to the moped, the release of the throttle does not necessarily lead to high HC emissions.

In summary, it can be stated that many of the high noise emission events stated in Table 2.1 correspond to operating conditions with high pollutant emission. An overview of the findings per operating condition is given in Table 2.2 below.

Table 2.2: LV driving conditions for which high pollutant emissions are expected

Condition	Relevant for pollutant emissions
'max' acceleration from standstill, G1, G2	Although information about gears was not available from the test data, it can be concluded that acceleration is a critical factor for emission of the three pollutants discussed in this section.
acceleration from standstill, G1, G2 Loaded + unloaded	
Acceleration at speed from 50 to 100 kmh	
max rpm esp. mopeds, scooters, sports MCs	RPM data was not available for this study. Therefore, the conclusions regarding engine speed are limited. However, given the dependency of vehicle power from engine speed, high RPM may correspond to high pollutant emissions under certain conditions.
release from constant speed or from accelerations	This condition is particularly relevant for unburnt hydrocarbons.
rpm burst	Due to missing RPM data no conclusion can be made regarding RPM burst and fluctuation.
rpm fluctuation	
backfire (occurrence, distance not critical)	The occurrence of backfiring events could not be identified in the available data. Therefore, no conclusion could be made.
Cold start (mainly for emissions)	Yes. Especially for CO and HC elevated levels of mass emission were measured under this condition.

2.5 Detection and occurrence of critical conditions in real-world data sources

2.5.1 Approach

Real-world data sources in this context are in-use data collected from L-category vehicles that were driven in real traffic. At least vehicle speed and engine speed should be measured for a series of different trips and vehicles with 1 Hz or higher resolution. Additional parameters like road gradient and speed limit of the road are highly recommended.



If the sample rate of the data is higher than 1 Hz it is recommended to compress it to 1 Hz in order to get better results for parameters that are calculated from the measured ones (e.g. acceleration).

The critical relevant driving conditions associated with critical emission events, as proposed by TNO, are shown in the Table 2.3.

Table 2.3: Critical LV driving conditions further specified

No	Condition	Vehicle operation	Roadside/ onboard	Remarks
1	'max' acceleration from standstill, G1, G2	Acceleration	Both	'rpm shortacc'
2	acceleration from standstill, G1, G2	Acceleration, late gear change	Both	'rpm longacc'
3	Acceleration at speed from 50 to 100 kmh	Acceleration, maybe varied	Both	'rpm acc at midspeed'
4	max rpm passby esp. mopeds, scooters, sports	Constant speed with max rpm	Both	'rpm conthi'
5	release from constant speed	Decelerating	Both	'rpm dropoff'
6	rpm burst	Stationary	Roadside	'rpm burst'
7	rpm fluctuation	Variable	Both	'rpm fluct'
8	backfire check	Multiple gear changing	Either	Detect any occurrence, distance not critical

In order to enable a filtering of such driving conditions from an in-use database, the data should be separated per vehicle/trip combination in different “sections” and these sections should be numbered in order to detect them in the database and collect the driving condition parameters in separate tables.

This separation or indication should be done in the following two steps:

- Step 1

Separate the data for a vehicle/trip combination into stop phases and short trips.

A stop phase is a continuous period of time with vehicle speeds below 1 km/h.

A short trip is a continuous period of time with vehicle speeds ≥ 1 km/h.

- Step 2

Separate the data within a short trip into acceleration, constant speed and deceleration phases.

The borderlines between these phases are acceleration values of ± 0.2778 m/s² (± 1 km/h/s).

These thresholds were the results of sensitivity analyses within the WMTC development.

The indication of the different driving condition phases can be done by adding “true/false” columns for the different driving conditions described before. Then sections with consecutive “true” samples should be numbered in order to allow statistical analyses like duration or distance distributions.

For the stop phases the following parameters should be collected in a separate table:

- Vehicle and trip number,



- Start and end time within the trip, stop duration,
- Minimum, average and maximum engine speed.

The latter would allow to filter the condition 6 of Table 2.3.

For the acceleration, constant speed and deceleration phases the following parameters should be collected in separate tables:

- Vehicle, trip and short trip number,
- Start and end time within the trip,
- Duration and distance,
- Minimum, average, maximum, start value and end value of
- Vehicle speed v ,
- Acceleration a ,
- $v \cdot a$,
- Engine speed.

For the vehicle speed, the minimum and maximum values should be equal to the start and the end values for acceleration and deceleration phases. But for the other parameters this is not necessarily the case. E.g., if the engine speed at the start is higher than the minimum engine speed during an acceleration phase this could indicate an upshift during the phase took place. If the engine speed at the start is lower than the maximum engine speed for a deceleration phase this could indicate a downshift during the phase.

In this context it is recommended to indicate gearshifts in the data separately. But this is only useful if the engine speed could be measured accurately enough.

For short trips the following parameters should be collected in addition to those already mentioned for the driving condition phases:

- Average negative and positive values for acceleration and $v \cdot a$,
- Relative positive and negative acceleration, (RPA, RNA).

The relative positive acceleration RPA is the sum of all $v \cdot a$ samples with positive acceleration over the whole short trip divided by the distance driven within the whole short trip. This parameter can be interpreted as acceleration but also as specific acceleration energy per vehicle mass and distance driven.

The relative negative acceleration RNA is calculated in the same way as the RPA but using $v \cdot a$ samples for negative acceleration instead of positive ones.

2.5.2 Application of the indicated approach for the conditions specified in Table 2.3 and results for the EU WMTC database

In this section, the conditions specified in in Table 2.3 are filtered from the database that was used to develop the EU WMTC, to determine the timeshare of these conditions in real-world driving data.



Conditions 1 & 2:

Conditions 1 and 2 are both dedicated to accelerations from standstill. These can be filtered out by searching for acceleration phases that have the same start time as the corresponding short trip.

It is recommended to merge conditions 1 & 2 and to not differentiate these by the duration.

The filtering of appropriate acceleration phases can be done by choosing an appropriate threshold for the ratio between n_{\max} of the acceleration phase and n_{rated} . The threshold has been put here at $\geq 80\%$.

The analysis of the EU part of the WMTC database leads to the following result in Table 2.4:

Table 2.4: Occurrence of driving conditions 1 & 2 in the EU WMTC database (timeshares).

Idveh	number of acc > 1 s	number of acc with $n_{\max} \geq 0.8 * n_{\text{rated}}$	share on total driving time	dur_min in s	dur_ave in s	dur_max in s	v_start_min in km/h	v_start_ave in km/h	v_start_max in km/h	v_end_min in km/h	v_end_ave in km/h	v_end_max in km/h
1	319	19	0.12%	4	8.5	22	1.3	6.3	14.2	55.8	88.9	141.2
2	365	12	0.07%	4	7.9	14	1.1	5.4	14.3	77.5	106.8	160.7
3	117	4	0.10%	6	11.0	17	4.0	5.8	8.9	65.0	90.7	117.0
37	443	16	0.20%	6	13.0	22	1.2	5.0	10.4	52.3	69.8	86.4
38	388	2	0.02%	7	8.0	9	1.7	4.4	7.1	91.6	101.0	110.4
39	409	0	0.00%									
40	135	1	0.02%	8	8.0	8	11.4	11.4	11.4	96.8	96.8	96.8
41	128	0	0.00%									
42	534	352	3.46%	2	11.5	27	1.0	3.8	8.0	8.9	55.8	80.3
43	416	240	1.92%	2	9.5	21	1.0	4.7	12.6	23.9	56.6	79.7
44	478	299	2.67%	3	10.4	21	1.0	4.7	13.2	20.4	55.8	79.2
mot	2304	54	0.08%									
scooters	1428	891	2.68%									

Please note that vehicles 42 to 44 are 125 cm³ scooters with a CVT transmission.

It was observed that v_{end} is higher than 60 km/h for motorcycles for most acceleration phases with n_{\max} above 80% of n_{rated} .

Condition 3 (acceleration phases with v_{start} between 30 km/h and 80 km/h):

Condition 3 is dedicated to accelerations from vehicle speeds between 50 and 100 km/h. It is recommended to modify this to a speed range from 30 and 80 km/h so that it fits the whole range of vehicles from scooters and low powered vehicles to high powered vehicles. See also Figure 2-24.

The filtering of appropriate acceleration phases can be done based on the same threshold as before for the ratio between n_{\max} of the acceleration phase and n_{rated} ($\geq 80\%$).

The analysis of the EU part of the WMTC database leads to the result as shown in the following table:



Table 2.5: Occurrence of driving condition 3 in the EU WMTC database

ldveh	number of acc > 1 s	number of acc with n_max >= 0.8*n_rated	share on total driving time	dur_min in s	dur_ave in s	dur_max in s	v_start_min in km/h	v_start_ave in km/h	v_start_max in km/h	v_end_min in km/h	v_end_ave in km/h	v_end_max in km/h
1	3420	245	1.37%	3	7.4	24	30.3	59.3	79.9	57.9	103.8	170.2
2	3624	80	0.43%	4	7.4	18	30.4	62.0	79.5	77.8	126.2	174.1
3	1144	50	0.88%	3	8.1	17	31.8	58.5	79.0	68.8	93.1	125.7
37	2524	128	0.95%	3	7.9	15	30.2	55.7	79.6	44.8	76.5	96.7
38	2154	2	0.02%	7	8.5	10	31.7	46.2	60.6	120.4	122.5	124.7
39	2654	10	0.15%	9	16.4	23	43.6	62.0	79.2	78.6	117.4	130.5
40	350	8	0.22%	4	9.9	26	30.7	55.4	78.7	70.6	112.1	142.2
41	479	3	0.09%	9	10.0	11	39.9	49.7	67.1	72.0	92.7	106.1
42	2004	1970	9.98%	3	5.9	20	30.0	48.4	78.2	35.8	60.7	84.3
43	1914	1004	4.75%	3	5.6	17	30.0	50.3	80.0	38.3	63.9	91.7
44	1777	1362	6.27%	3	5.4	20	30.0	49.7	79.8	37.7	61.5	93.2
mot	16349	526	0.59%									
scooters	5695	4336	6.99%									

v_{start_ave} is between 46 km/h and 62 km/h. So, most of these acceleration phases occur at the transition from urban to rural roads or at motorway entrance ramps.

For a more general assessment of the start speeds for acceleration phases their distributions are shown in Figure 2-24 for the EU WMTC database. This shows that the frequency of start speeds of acceleration phases depends on the vehicle class with the power to mass ratio as most important parameter, hence the use of different start speed ranges instead of one common range could be an alternative. Further discussions about this topic are foreseen.



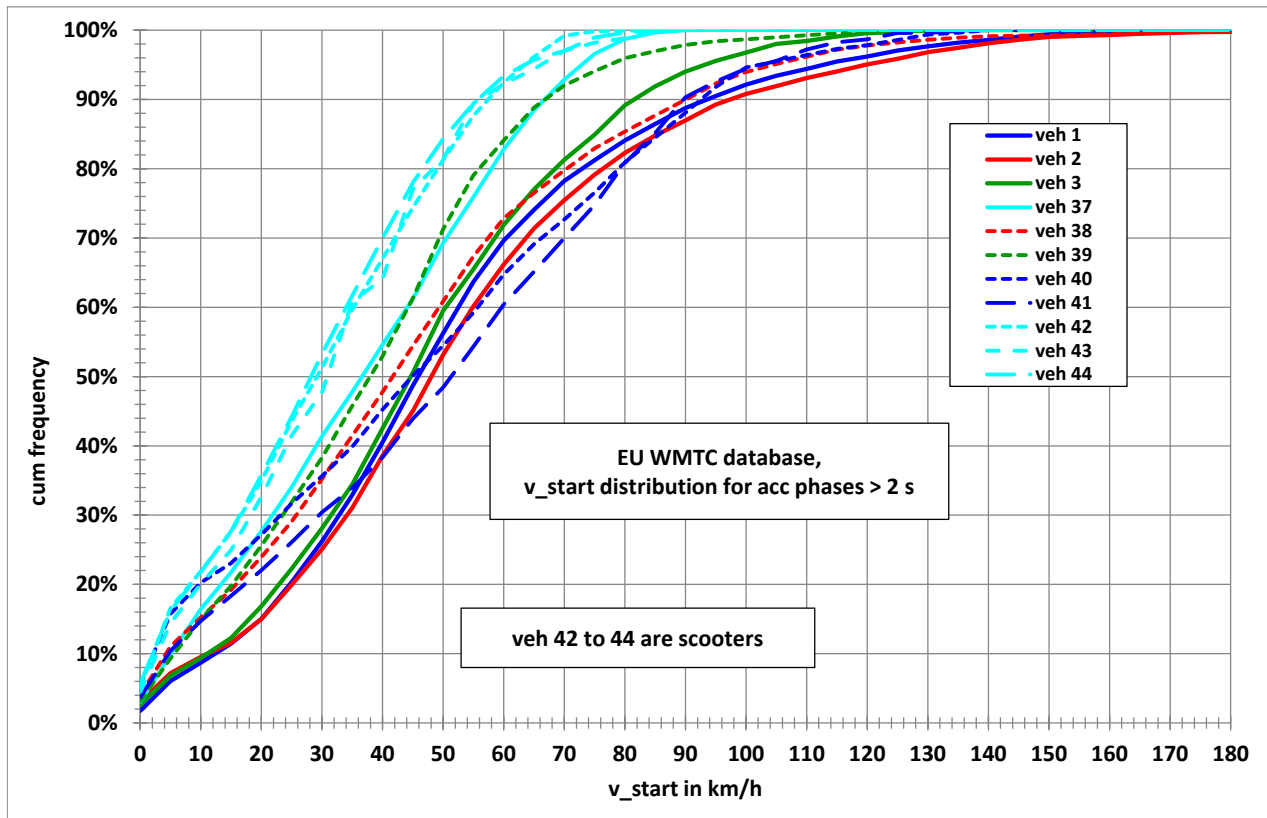

Figure 2-24: v_{start} frequency distributions for acc phases > 2 s

Condition 4

Condition 4 is dedicated to constant speed phases for high vehicle speeds.

The steps for filtering out condition 4 are as follows:

- Calculate frequency distribution of v_{ave} for cruise phases > 2 s (see Figure 2-25),
- Determine appropriate speed ranges from these distributions (in the WMTC example v_{ave} values between 80 km/h and 90 km/h were chosen),
- Determine cruise phases with $n_{ave} \geq 0.8 \cdot n_{rated}$.



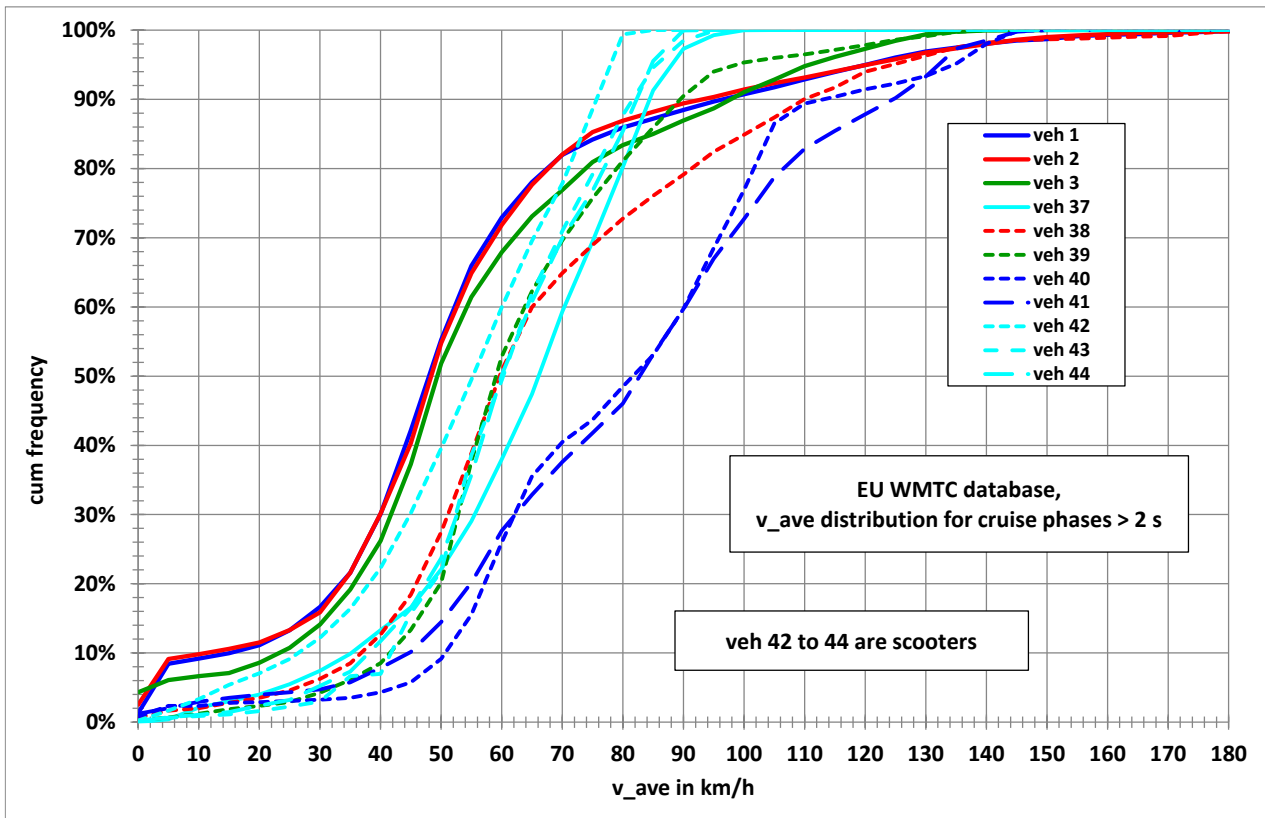

Figure 2-25: v_{ave} frequency distributions for cruise phases > 2 s

The results are shown in the following table:

Table 2.6: Occurrence of driving condition 4 (for v_{ave} values between 80 km/h and 90 km/h) in the EU WMTC database

ldveh	number of cruise phases > 2 s with v_{ave} between 80 km/h and 90 km/h	number of these cruise phases with $n_{ave} \geq 0.8 * n_{rated}$	share on total driving time	dur_min in s	dur_ave in s	dur_max in s	n_{ave_min} / n_{rated}	n_{ave_ave} / n_{rated}	n_{ave_max} / n_{rated}	v_{ave_min} in km/h	v_{ave_ave} in km/h	v_{ave_max} in km/h	v_{max_min} in km/h	v_{max_ave} in km/h	v_{max_max} in km/h
1	149	0	0.0%												
2	135	0	0.0%												
3	75	1	0.0%	4	4.0	4	80.9%	81.6%	82.3%	87.6	87.6	87.6	88.3	88.3	88.3
37	731	249	4.0%	3	17.1	121	80.1%	81.7%	83.1%	85.7	87.6	90.0	86.0	89.1	94.1
38	184	0	0.0%												
39	414	0	0.0%												
40	116	0	0.0%												
41	181	0	0.0%												
42	163	159	7.2%	3	52.6	531	1.1	1.2	1.2	80.0	81.4	85.4	80.9	82.9	86.4
43	807	805	7.4%	3	10.9	77	0.9	0.9	0.9	80.0	83.7	90.0	80.2	84.4	91.8
44	934	934	7.9%	3	9.9	108	1.0	1.0	1.1	80.0	84.7	90.0	80.4	85.4	91.9
mot wo veh 37	1254	1	0.0%												
scooters	1904	1898	7.5%												



The chosen speed range is only meaningful for scooters because it is their v_{max} range. For small, low powered motorcycles with v_{max} slightly above the speed range of 80 km/h to 90 km/h also significant percentages of condition 4 events can be found (see vehicle 37 in the above table). For the other motorcycles shares as shown in Table 2.6 can be determined for higher vehicle speed ranges close to their maximum speeds.

Condition 5

The condition 5 is dedicated to the transition from constant speed phases to deceleration phases. It is recommended to include also transitions from acceleration phases to deceleration phases. These conditions can be filtered by searching for the end time of the constant speed or acceleration phases and deceleration phases which have a start time one second later. The further filtering/analysis can be done analogous to the approach as described for the acceleration conditions (filtering dec phases with $n_{max} \geq 0.8 * n_{rated}$).

The results for deceleration phases following a cruise phase are shown in Table 2.7, the results for deceleration phases following an acceleration phase are shown in Table 2.8.

Table 2.7: Filtering results for condition 5a (deceleration phases following a cruise phase) for the EU WMTC database

ldveh	number of dec phases > 2 s following a cruise phase	number of these dec phases with $n_{max} \geq 0.8 * n_{rated}$	share on total driving time	dur_min in s	dur_ave in s	dur_max in s	v_start_min in km/h	v_start_ave in km/h	v_start_max in km/h	v_end_min in km/h	v_end_ave in km/h	v_end_max in km/h	n_max_min in min-1	n_max_ave in min-1	n_max_max in min-1
1	3905	234	1.13%	3	6.4	21	38.7	145.5	198.4	2.3	120.8	182.4	80.3%	92.5%	135.8%
2	3828	64	0.30%	3	6.6	22	104.7	174.3	232.8	54.6	133.9	205.9	80.7%	91.6%	117.1%
3	1266	29	0.44%	3	6.9	15	74.0	119.6	152.4	3.9	86.9	132.3	80.5%	86.0%	99.9%
37	3119	260	1.66%	3	6.8	27	50.4	88.9	103.0	1.6	63.9	97.4	80.0%	85.2%	139.9%
38	2656	0	0.00%												
39	3157	84	0.49%	3	6.5	21	108.3	124.0	145.0	1.2	102.4	141.7	80.4%	91.9%	107.5%
40	653	16	0.23%	3	5.3	12	139.4	143.0	153.6	93.2	129.3	144.7	80.4%	82.5%	88.5%
41	820	0	0.00%												
42	3023	1900	10.66%	3	6.6	29	13.6	66.8	87.1	1.1	41.6	79.8	80.6%	98.9%	125.1%
43	2696	391	2.20%	3	6.7	22	57.3	80.2	99.1	1.1	53.6	92.3	80.0%	85.8%	108.0%
44	2799	981	5.72%	3	6.8	19	32.9	69.5	91.7	1.0	41.9	86.8	80.0%	91.9%	145.3%
mot	27922	3959	0.65%												
scooters	8518	6.96	6.17%												

Table 2.8: Filtering results for condition 5b (deceleration phases following an acceleration phase) for the EU WMTC database

ldveh	number of dec phases > 2 s following an acc phase	number of these dec phases with $n_{max} \geq 0.8 * n_{rated}$	share on total driving time	dur_min in s	dur_ave in s	dur_max in s	v_start_min in km/h	v_start_ave in km/h	v_start_max in km/h	v_end_min in km/h	v_end_ave in km/h	v_end_max in km/h	n_max_min in min-1	n_max_ave in min-1	n_max_max in min-1
1	1896	300	1.53%	3	6.7	30	62.8	130.0	189.3	3.5	95.1	169.8	80.0%	90.2%	122.5%
2	2772	201	0.97%	3	6.7	22	100.6	154.3	226.9	2.8	106.1	200.8	80.1%	91.9%	114.6%
3	525	43	0.51%	3	5.5	20	69.9	99.7	135.0	10.6	73.7	121.2	80.2%	88.2%	100.4%
37	659	17	0.08%	3	5.1	10	58.7	74.3	90.5	17.1	52.8	86.4	80.2%	90.3%	149.1%
38	1238	3	0.02%	5	6.0	8	121.0	176.6	207.0	46.9	134.1	179.2	82.2%	84.8%	89.0%
39	744	2	0.01%	3	3.5	4	105.4	109.9	114.5	101.7	102.4	103.2	85.4%	90.5%	95.7%
40	130	3	0.04%	3	4.3	7	75.8	122.8	148.2	51.5	109.6	144.2	83.3%	85.0%	85.9%
41	203	0	0.00%												
42	799	478	2.42%	3	5.9	22	11.5	58.2	87.5	1.2	34.8	72.2	80.6%	94.0%	127.7%
43	547	46	0.24%	3	6.6	17	46.7	71.5	90.9	1.1	43.8	83.5	80.0%	83.4%	92.9%
44	609	167	0.90%	3	6.2	23	20.0	65.5	114.1	1.2	40.8	95.6	80.1%	89.6%	196.4%
mot	8167	569	0.54%												
scooters	1955	691	1.18%												

The average start speeds for condition 5 events are between 100 km/h and 177 km/h for medium and high powered motorcycles and between 58 km/h and 89 km/h for low powered motorcycles and scooters, which is significantly lower.

Condition 6 (engine speed bursts at standstill)

The condition 6 is dedicated to the stationary vehicle and thus to stop phases. The steps for filtering out condition 6 are as follows:

- Calculate n_{start} , n_{min} , n_{ave} , n and n_{end} for stop phases > 2 s,
- Determine n_{max}/n_{end} and n_{max}/n_{rated} ,
- Determine number of stop phases > 2 s and out of these the number of phases with $n_{max} > n_{end}$ and $n_{max} > 0.5 * n_{rated}$.

The results are shown in the following table:

Table 2.9: Filtering results for condition 6 (engine speed bursts at standstill) for the EU WMTC database

stops > 2 s		n_burst: n_max > 0.5*n_rated	
ldveh	number of stops	number of stops with n_burst	share
1	349	4	1.1%
2	395	1	0.3%
3	131	0	0.0%
37	462	14	3.0%
38	444	1	0.2%
39	412	0	0.0%
40	171	1	0.6%
41	239	1	0.4%
42	563	205	36.4%
43	494	13	2.6%
44	534	33	6.2%
sum	4194	273	6.5%

Please note that vehicles 42 to 44 are scooters, vehicle 37 is the smallest motorcycle.

Such bursts were found for scooters and the smallest motorcycle but were not significant for the other vehicles.

Condition 7

The condition 7 is described as “rpm fluctuations for variable vehicle operation”.

It is currently not possible to filter these conditions from an in-use database where the engine speed is missing. And even when the engine speed was measured it is difficult to differentiate between gearshifts and condition 7 events. This condition needs to be further elaborated.

Condition 8

The condition 8 is the detection of backfire conditions.

This condition cannot be detected based on the parameters that were measured during in-use data acquisition campaigns.



2.6 Detection and occurrence of critical conditions in type approval cycles

In order to find out to what extent the critical conditions specified in in Table 2.3 occur in the WMTC type-approval cycle, the filtering algorithm has also been applied to determine the timeshare of these conditions in the WMTC, similarly to what was done in subsection 0. The result of this analysis was that none of the indicated critical conditions for high noise emissions occur in the WMTC. Only the cold start, which is seen as critical for pollutant emissions, is included in the WMTC. A further discussion and analysis to find out why these conditions are not included will be provided in section 3.3.

2.7 Evaluation and validation for noise emissions

In May, June and July 2023, noise and vehicle driving profile measurements were performed by TNO at three locations in Utrecht (the Netherlands), to evaluate and validate the critical conditions and driving parameters.

These measurements were mainly performed for the municipality to gain insight into the loudest vehicles, causes and potential remedies [40]. Within LENS, further validation of the proposed driving conditions was undertaken.

The locations were residential urban streets with 50 km/h speed limit and known complaints on loud vehicles including both L-vehicles and cars. Pictures of the locations are shown in Figure 2-26 below.



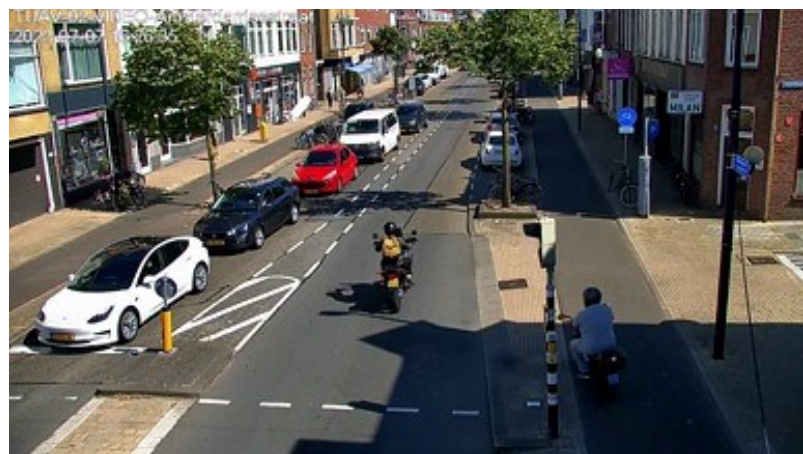

Figure 2-26: Three urban measurement locations in Utrecht for roadside monitoring of loud vehicles, indicated with WD (top), TK (middle) and AS (bottom).



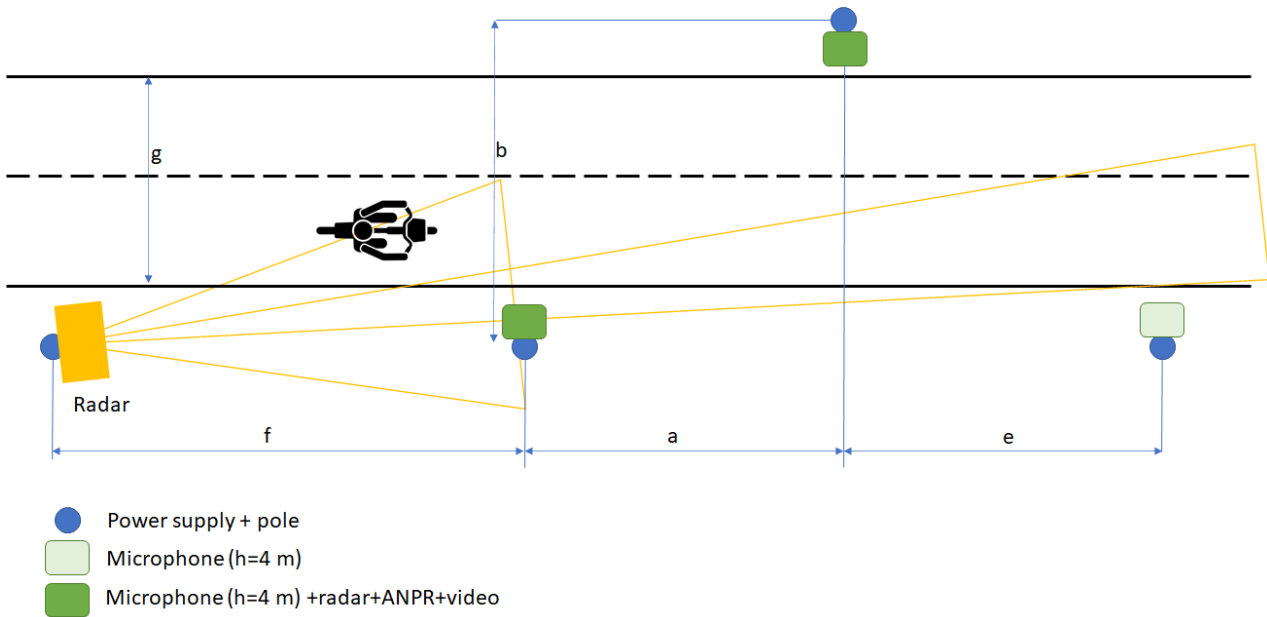

Figure 2-27: Measurement configuration. The dimensions a-g are different for each site, listed in Annex B.

The measurement configuration was as set out in Figure 2-27, where the dimensions for each site are different due to the road situation. These are listed for the Utrecht sites in Annex B. In addition to previous measurements in other cities [37][38][39], for the purpose of LENS, an extra microphone and a separate speed radar were added, capable of tracking the vehicle over the whole road stretch of interest. This was intended to obtain a speed-acceleration profile of the vehicles. Vehicle type and properties were determined with license plate recognition cameras (ANPR) and video, both anonymised for data privacy reasons. The measurements were performed during seven days at each location, resulting in around 1500 loud events of vehicles above 80 dB(A) at the roadside (based on two positions). These include all types of L-vehicle and cars. The loud events were identified by selecting the L_{pAFmax} sound level in a signal sample of 20 seconds. The exact position of this event is normally near the microphone, although it may differ in the case of strong variation in speed or acceleration. In those cases however, the sound level would only be higher, if measured at the loudest position along the road. But for recognising the driving condition, the exact sound level is less relevant.

In Figure 2-28, a histogram of vehicle sound labels is shown for all the selected loud vehicles measured in Utrecht. This shows that the driving conditions *rpmshortacc*, *rpmburst* and *rpmconthi* followed by *rpm longacc* are the most frequent. It should be noted that the uncertainty in these numbers strongly depends on the algorithm applied, and some driving conditions can be mixed with others. In addition, the sound label is based on the moment of maximum sound during the pass-by, whereas some sounds occur further away from the measurement position, in particular backfire bangs.

Figure 2-29 shows the roadside L_{pAFmax} sound levels of loud vehicles in a histogram for each vehicle type including cars, motorcycles, mopeds, trikes and quads.

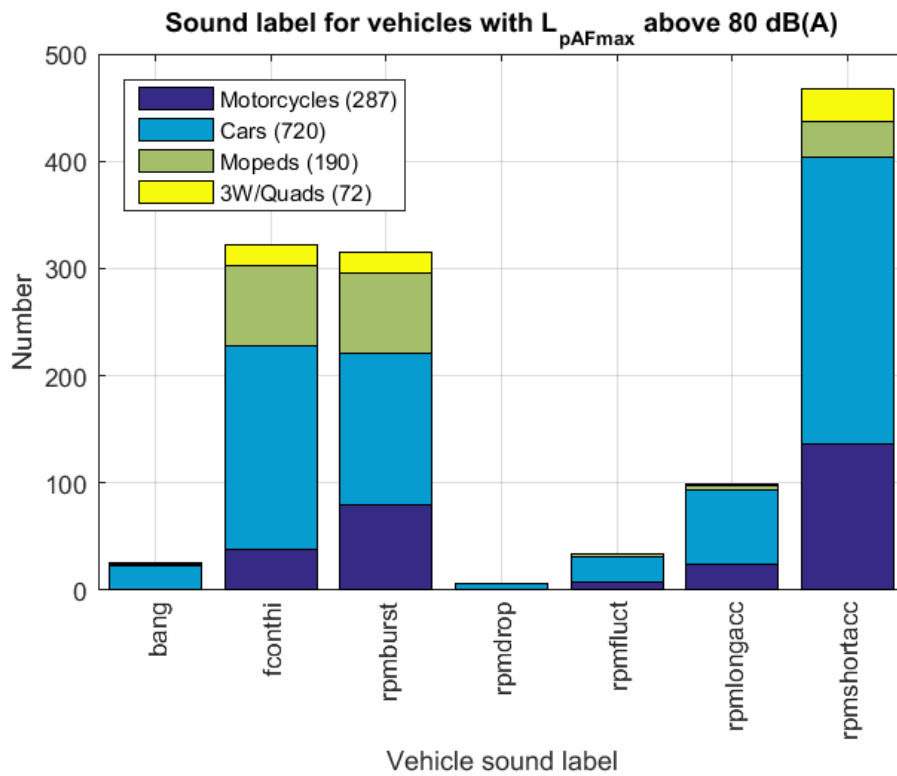

Figure 2-28: Histogram of vehicle sound labels for loud vehicles at 3 sites in Utrecht

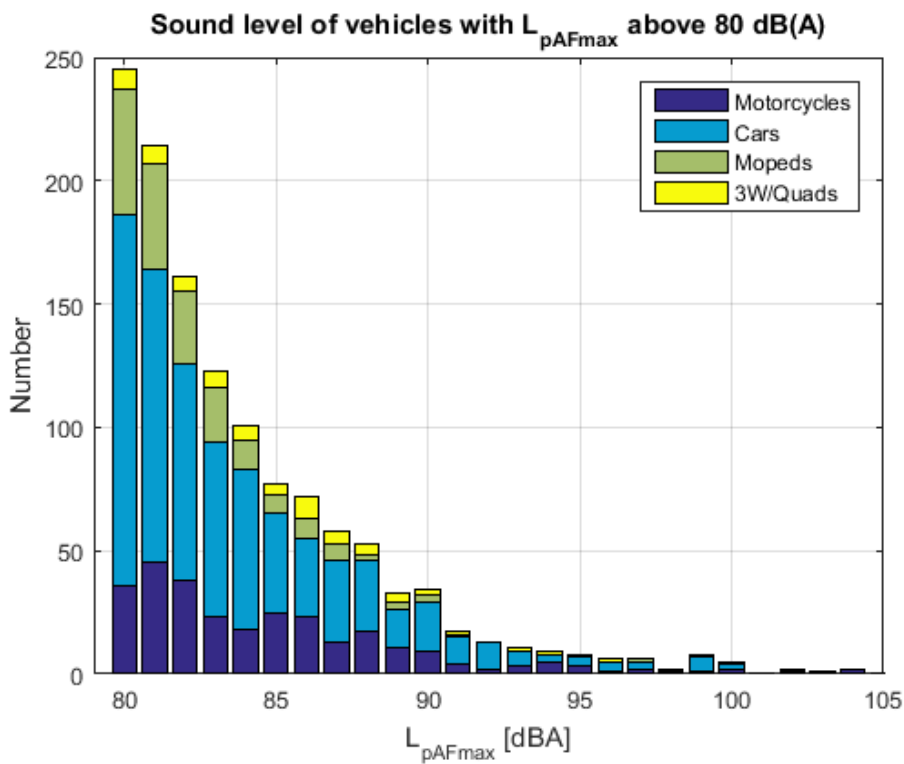

Figure 2-29: Histogram of vehicle sound levels per vehicle type for loud vehicles at 3 sites in Utrecht for 7 days each



The sound levels of the loud passbys measured at two positions are set out as a function of time and in Figure 2-30, both per vehicle type (top) and per vehicle sound label.

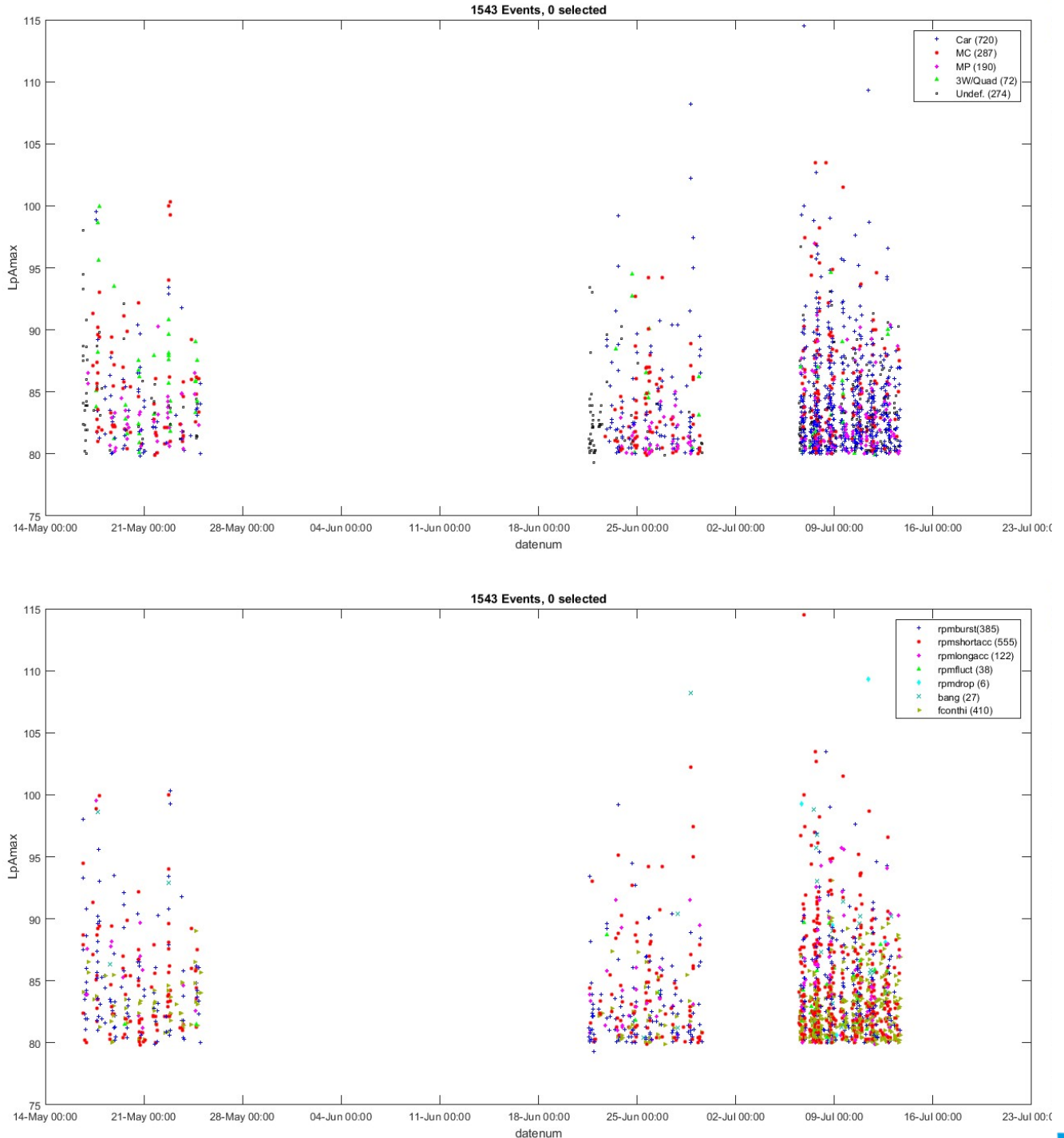

Figure 2-30: Vehicle pass-by sound levels $L_{pA_{max}}$ above 80 dB(A) for three locations measured at two roadside positions. Top: showing vehicle type where identified; bottom: same data but indicating the vehicle sound label.



The proposed driving conditions were again found at the Utrecht measurement sites, with conditions `rpmshortacc`, `rpmburst` and `rpmconthi` followed by `rpmlongacc` being most frequent. These are generally easily recognised audibly. Some are less easily identified if they occur further away from the measurement position. They can also occur in combination, for example in the case of engine revving before acceleration from standstill, during gear changing or during deceleration, or driving above the speed limit at the location concerned. Further refinement of algorithms to determine the driving condition from sound is recommended.

The detailed sound features of selected loud events illustrative of particular driving conditions are included in Annex B. These show that most of the loud pass-bys contain strong dynamic content, with the exception of the `rpmconthi` condition, which is most common for mopeds.

Results from the Utrecht locations are shown in figures B-13 -Figure B-26, followed by spectrograms for a series of loud events measured at three positions along the road. These show how the driving conditions vary over a distance of around 50 m.

2.8 Evaluation and validation for pollutant emissions

As indicated in Section 2.1.1, one of the main influencing parameters for exhaust emissions are vehicle speed and acceleration, which translate into engine load and engine speed via the gearbox. To evaluate the occurrence of these parameters in real-world circumstances, a vehicle radar system was added to the measurement locations. Unfortunately, it was not possible to combine the vehicle radar with the license plate recognition data. For that reason there was no opportunity to connect the vehicle category to the speed and acceleration profiles, making it impossible to evaluate these for individual vehicle categories.

Nevertheless, the maximum acceleration distribution for all vehicles is shown in Figure 2-31. This contains only L-category vehicles -ranging from mopeds to high powered two-wheelers- and shows the highest acceleration value over the short distance that the vehicle was traced. The first two bins with very low accelerations up to 0.5 m/s^2 are left out from this figure as their dominance would reduce the scale of the higher acceleration bins.



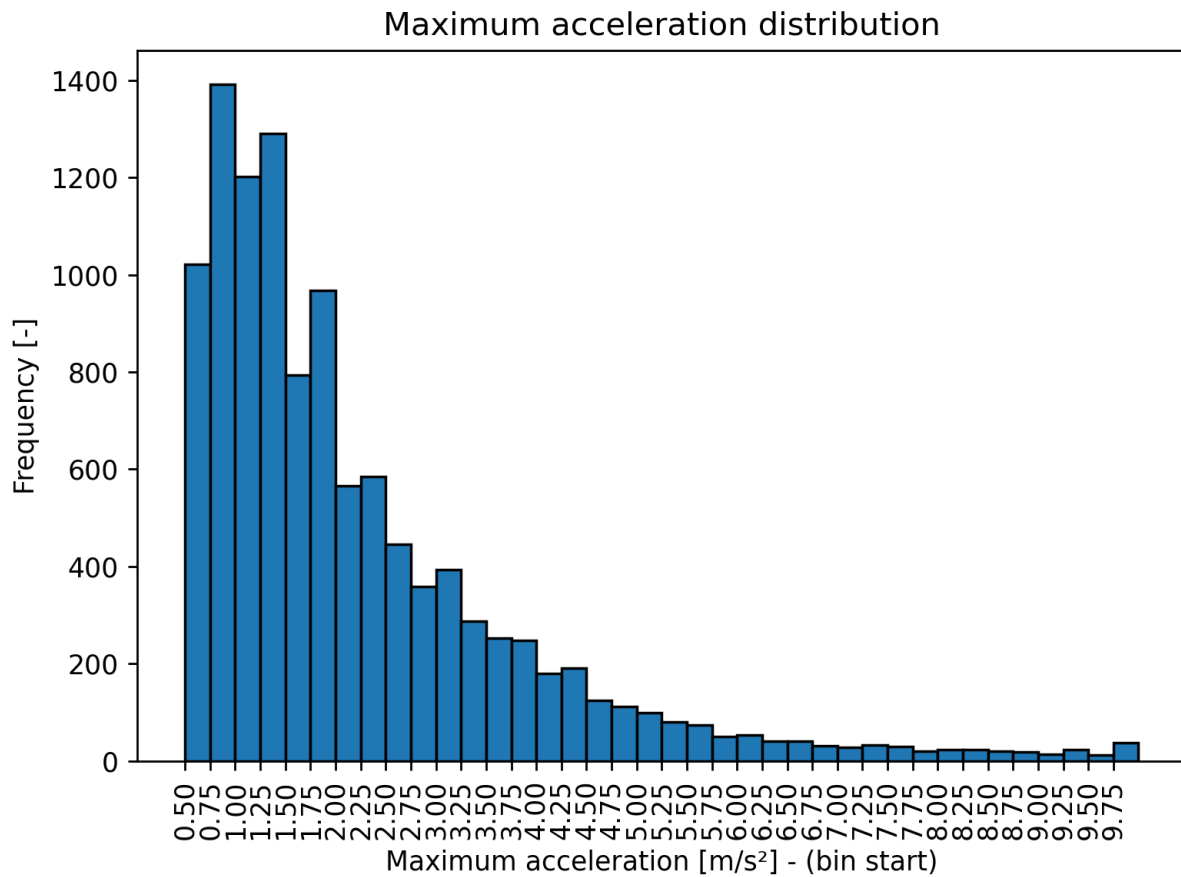

Figure 2-31: Maximum acceleration distribution for radar measurements at the first two locations in Utrecht

It can be seen that the majority of (maximum) accelerations are fairly low. It has to be noted here that these accelerations are just a snapshot of normal on-road driving behaviour, and are highly influenced by the location where they are measured. Moreover, as the data includes all L-categories, also mopeds and quads are included. In the Netherlands, different moped categories exist which have a maximum speed of either 25 or 45 km/h. The largest share of the mopeds in the Netherlands have a maximum (construction) speed of 25 km/h. Clearly, these vehicles have accelerations which are substantially lower than motorcycles, and will therefore dominate the lower acceleration bins. Radar data was only available for the first two locations shown in Figure 2-26. As can be seen, both are in urban areas with a main road that has two lanes and a maximum speed of 50 km/h. The first location may have variable speeds due to the presence of a side junction while the second is a long straight road which may be tempting to overspeed. On these road stretches one would not expect to see high accelerations since there are no external triggers for acceleration². Nevertheless, the observed maximum accelerations go up to 10 m/s². With such high acceleration, a speed of 100 km/h would be reached within a few seconds.

² The third location is directly after a traffic light, where higher accelerations would be expected as the vehicles may have been waiting for a red light. Unfortunately, the acceleration data was not available for this location.



This acceleration distribution can be compared to the that of the WMTC, the testcycle used to determine exhaust gas emission levels of L-category vehicles. For this comparison, WMTC class 3-2 is used. This is the cycle for L-category vehicles with a design speed which is higher than 140 km/h. This cycle was chosen as this speed trace includes the highest accelerations, while it is not known which vehicle categories are included in the radar data.

In order to make a fair comparison, the acceleration distribution shown in Figure 2-32 is restricted to only the urban part of WMTC (0 to 600 seconds) since the radar locations are in an urban environment. Also here, the first two bins with very low accelerations up to 0.5 m/s² are left out of this figure. So as to allow a good comparison to the radar data, the same bins are used for the x-axis.

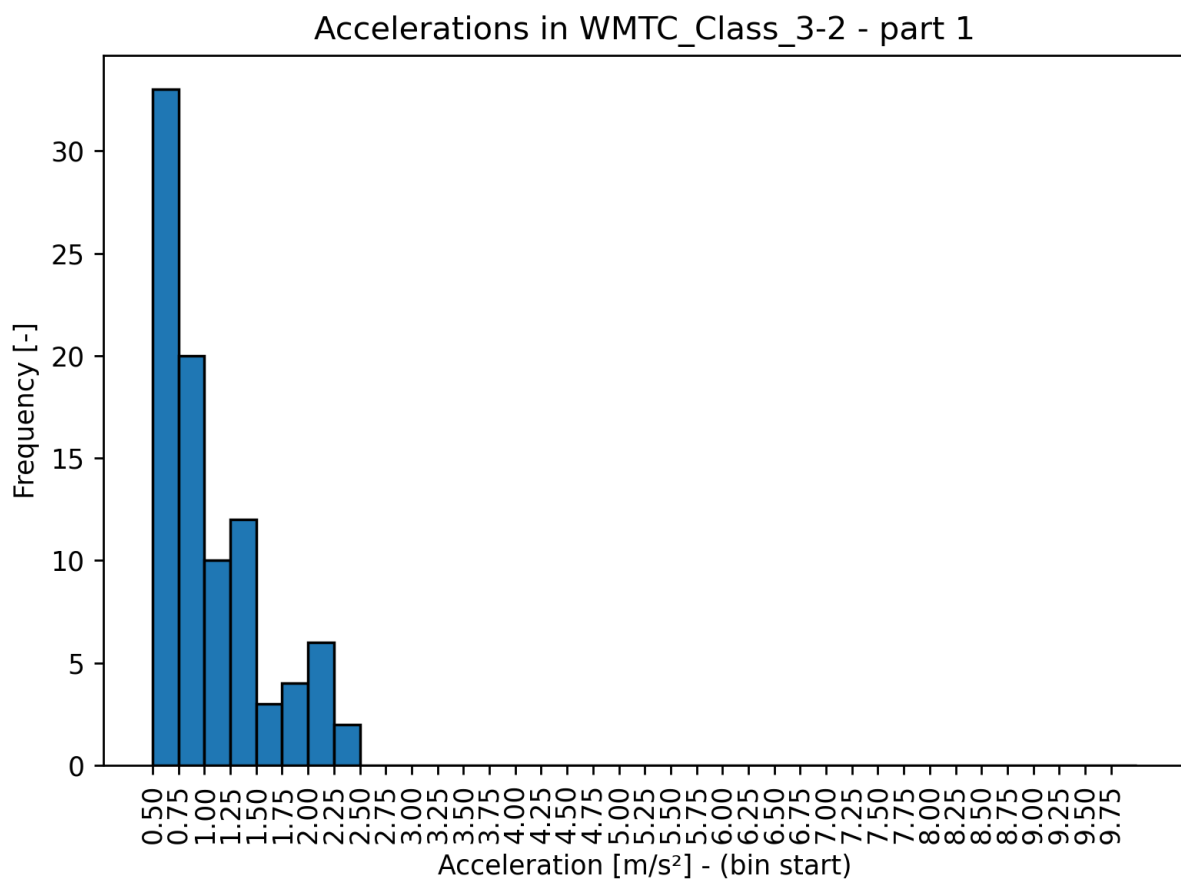

Figure 2-32: Maximum acceleration distribution for WMTC part I (urban part)

When comparing Figure 2-32 to Figure 2-31 it is clear that the maximum accelerations measured on the road are much higher than those of the WMTC class 3-2, which do not exceed a maximum of 2.5 m/s² (about 4 times less). Considering that acceleration is an important influencing parameter for exhaust emissions, the WMTC seems to reproduce only emissions during mild accelerations, while the real-world circumstances clearly show more severe accelerations. Of course, the evidence from this measurement campaign is anecdotal and should be verified by gathering more detailed data, but still provides a good indication for further research. Nevertheless, it is recommended that more severe



accelerations are included in the measurement campaign, either during on-road testing and/or on the chassis dynamometer.

A similar evaluation based on the speed distributions has been performed, but in the absence of information on the vehicle category, no clear conclusions could be drawn from this.

2.9 Fleet composition

The L-category vehicle fleet composition in the EU27 member states in 2020 has been analysed based on "COPERT data" [45], provided by EMISIA. The main factors considered are the vehicle type, engine capacity, fleet numbers per country and Euro number, which is indicative of age.

In Figure 2-33, the numbers of L-vehicles per country are set out. They are grouped as follows:

- MP2= 2-stroke moped < 50 cc, (L1,L2)
- MP4=4-stroke moped < 50 cc, (L1,L2)
- MC2=2-stroke motorcycle > 50 cc (L3,L4,L5)
- MC4-1=4-stroke motorcycle < 250 cc (L3,L4,L5)
- MC4-2=4-stroke motorcycle 250-750 cc (L3,L4,L5)
- MC4-3=4-stroke motorcycle > 750 cc (L3,L4,L5)
- QA= ATV/Quad/Buggy (L7)
- MI= Microcar (L6)
- MPE = electric moped (L1,L2)
- MCE = electric motorcycle (L3,L4,L5)
- MIE = electric microcar (L6)

This shows that motorcycles are by far the largest part of the fleet, followed by mopeds.

Within the motorcycles, those with lower engine displacement are most numerous. This may be because this segment also includes the larger scooters. This dataset does not distinguish two-wheeled vehicles from three-wheeled vehicles.

Figure 2-34 shows the LV fleet numbers in individual EU27 member states, indicating that the countries with the largest LV fleets, 5% or more, are Italy, Germany, Spain, France, Greece, Poland and the Netherlands. For these countries, the fleet numbers per category are set out in Figure 2-35.

The Euro class of L-vehicles in the whole EU27 fleet are shown in Figure 2-36. This shows that most of the LV fleet in the EU27 are Euro 3 or older.



EU-27 L-vehicle fleet size

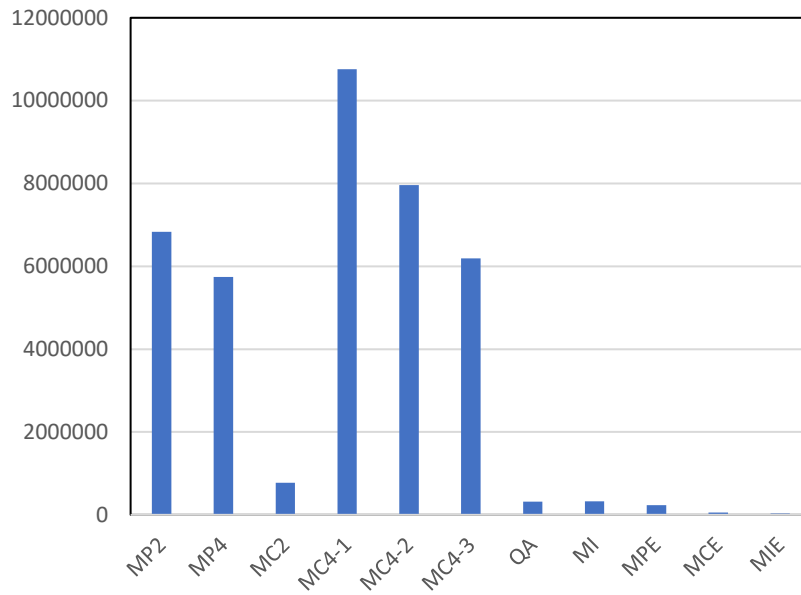

Figure 2-33: Fleet numbers of L-vehicles in whole EU27 in 2020

Percentage of L-vehicles of EU27 fleet

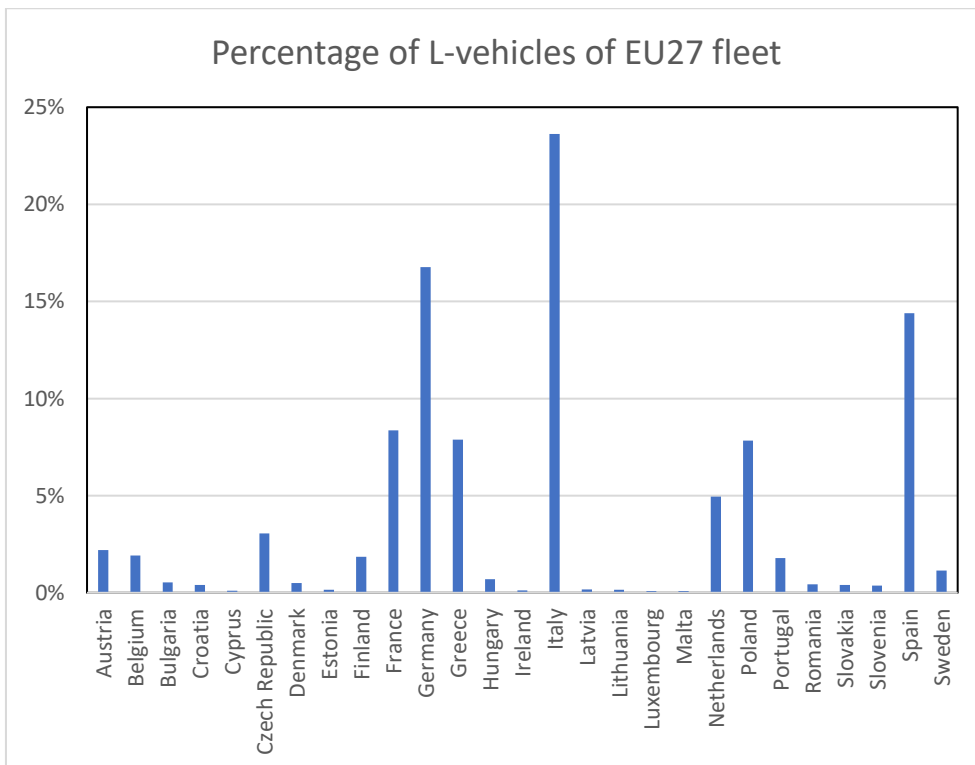

Figure 2-34: Percentage of EU27 L-vehicle fleet in individual member states in 2020



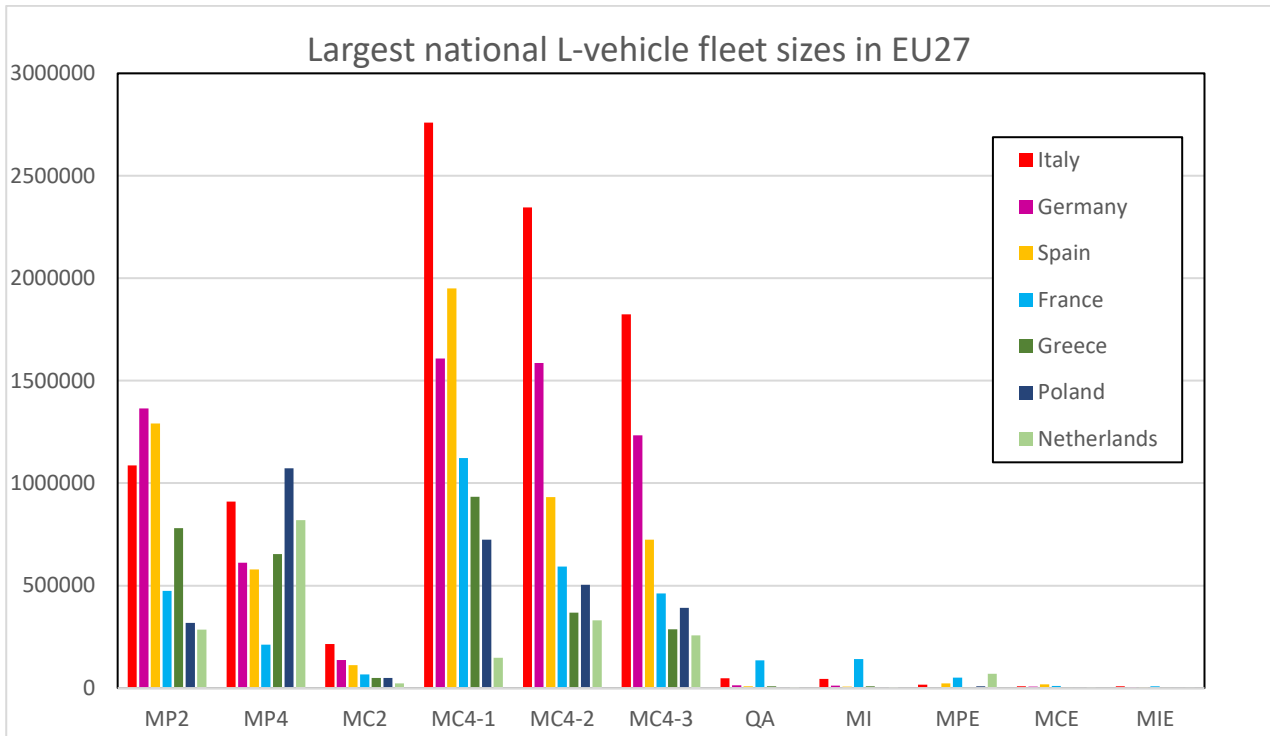

Figure 2-35: Fleet numbers of L-vehicles in EU27 member states with the largest fleets (>5% of EU27 fleet) in 2020

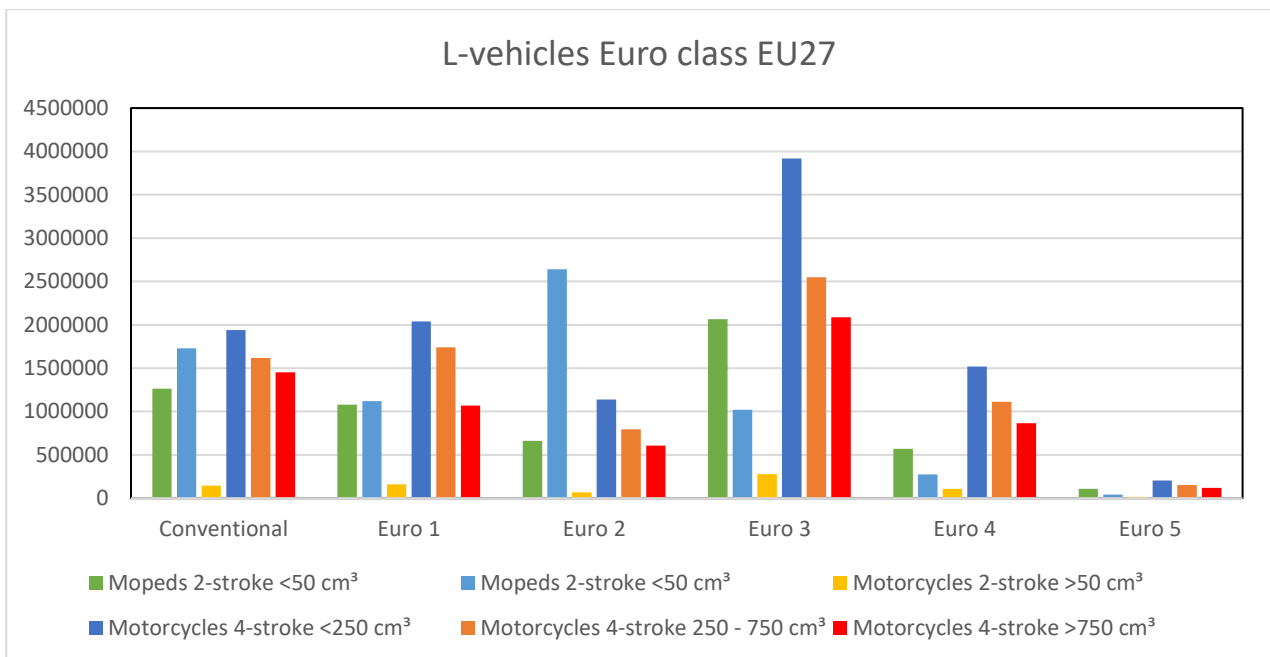

Figure 2-36: Figure 4: Euro class of L-vehicles in the EU27 fleet in 2020. 'Conventional' refer to vehicles without Euro class number, which are from before its introduction



3 Occurance of critical conditions in legislative test cycles

One of the aims of the LENS project is to determine to what extent the current type approval (TA) test protocols for noise and emissions are representative for critical driving conditions and parameters for high noise and emission events.

Noise and emissions are measured differently for type approval: noise is evaluated on a test site with an acceleration test, constant speed test and a stationary constant rpm test, whereas emissions are measured on a chassis dynamometer following a prescribed driving cycle.

The current TA procedures are described below for noise and emissions, followed by a comparison with the identified conditions for high noise and emission events.

3.1 TA Regulations for noise

The type approval regulations in the EU are covered by EU regulation 168/2013 [5] and its amendment 134/2014 [6], which specifies the prevailing UNECE regulations, as set out in Table 3.1. These stipulate test methods and sound limits for L_{pAFmax} for vehicle pass-by measured at 7,5 m distance, with the vehicle accelerating at full throttle, known as L_{WOT} . The measurement setup is shown in Figure 3-1. Also a stationary test is specified for the purpose of roadside checks of in-use compliance by police or vehicle authorities, measuring the L_{pAFmax} sound level at 50 cm at 45 degrees angle behind the exhaust outlet, with the engine running at a constant specified speed and releasing the throttle. The setup is shown in Figure 3-2. The limit for this test is shown on a plate fixed to the vehicle. Due to the smaller distance, this level is much higher than the pass-by level.

From 2012, the UN Regulation 41 (rev2, 04 series of amendments) for motorcycles (L3 category vehicles) [9] also specified a constant speed pass-by test resulting in sound level L_{cs} , whereby the sound limits were then applied to the L_{urban} level, which is a weighted average of L_{WOT} and the constant speed level L_{cs} . This effectively created a margin in the sound limits and allowed higher L_{WOT} levels, given that at the same time, a target acceleration was introduced. In order to close this gap, it is specified in subsection 6.2.3 of the regulation that L_{wot} shall not exceed the limit value for L_{urban} by more than 5 dB. Furthermore, "Additional sound emission provisions" (ASEP) were added to the sound emission requirements. The aim of these provisions is to ensure that the sound emission of the vehicle in real world driving conditions, that are not covered by the type approval test, is in line with the sound emission of the type approval test. See [GRB-47-11e \(unece.org\)](#) [12] and ASEP Overview 2017 [12].



The ASEP for UN R41 is currently under revision, see [‘real world’ coverage of the R41 ASEP proposal \(unece.org\)](https://www.unece.org) [14] and UN Regulation 41 (05 series of amendments) which will become applicable in the EU for new types of L3 category vehicles as of 01.01.2024 and for all types as of 01.01.2025 (aligned with the mandatory application of the “Euro5+” emission step).

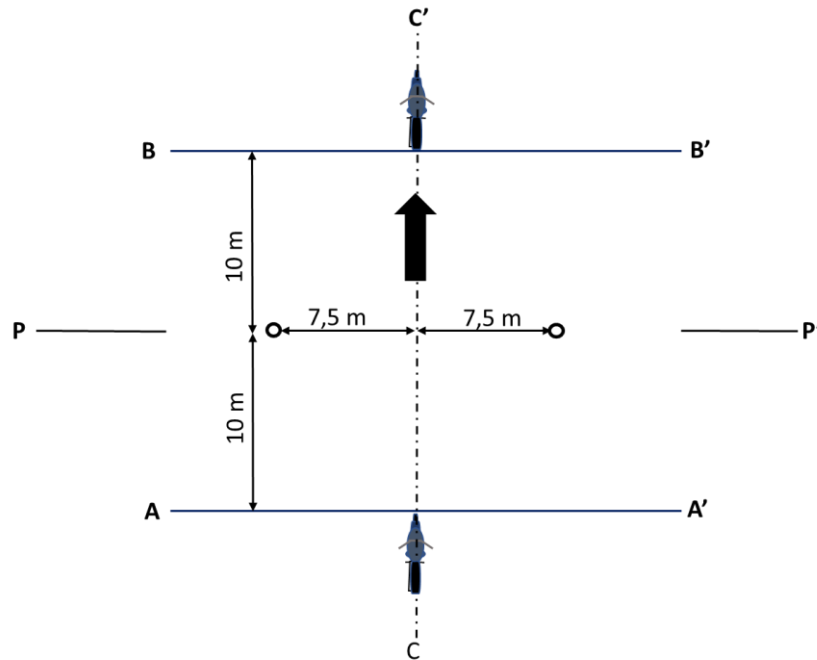

Figure 3-1: Test setup for pass-by sound measurement for L-vehicles. The vehicle approaches AA' and proceeds with wide open throttle, which is released at BB'.

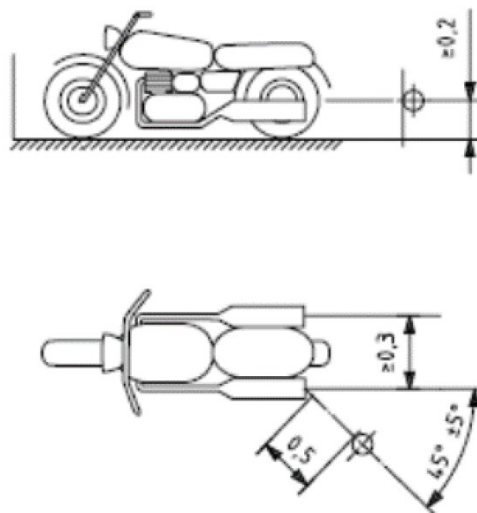

Figure 3-2: Test setup for stationary sound measurement of L-vehicles for roadside checks. The engine runs at constant specified speed, and the throttle is released.

The ASEP requires testing at additional engine speeds and vehicle speeds within the ASEP range, which must result in L_{WOT} levels below a derived curve relative to the reference measured L_{WOT} sound level.

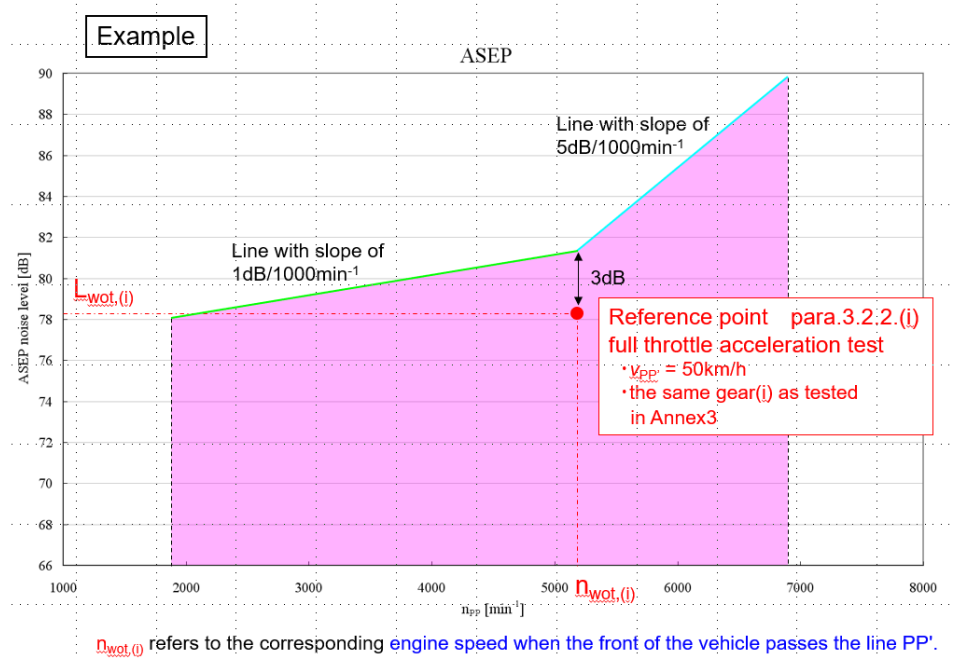

Figure 3-3: Example of ASEP test range showing the ASEP sound limit line based on the reference point from the normal WOT test. Any points measured for ASEP must be below the limit line. Taken from IMMA presentation at GRB ASEP meeting 11-13 July 2017 [12].

Table 3.1: Applicable UNECE Regulations for sound type approval of L-category vehicles as set out in EU Regulation 134/2014.

Vehicle (sub-)category	Vehicle category name	Applicable test procedure
L1e-A	Powered cycle	UNECE regulation No 63
L1e-B	Two-wheel moped $v_{\max} \leq 25$ km/h	
	Two-wheel moped $v_{\max} \leq 45$ km/h	
L2e	Three-wheel moped	UNECE regulation No 9
L3e	Two-wheel motorcycle Engine capacity ≤ 80 cm ³	UNECE regulation No 41
	Two-wheel motorcycle 80 cm ³ < Engine capacity \leq 175 cm ³	
	Two-wheel motorcycle Engine capacity > 175 cm ³	
L4e	Two-wheel motorcycle with side-car	
L5e-A	Tricycle	UNECE regulation No 9
L5e-B	Commercial tricycle	
L6e-A	Light quad	UNECE regulation No 63
L6e-B	Light mini-car	UNECE regulation No 9
L7e-A	On-road quad	
L7e-B	All-terrain vehicles	
L7e-C	Heavy mini-car	

Additional UNECE Regulations address noise control for more vehicle types, including three-wheel mopeds, tricycles, and quadricycles (Regulation 9) [10], two-wheel mopeds (Regulation 63) [8], and replacement silencers (Regulation 92) [11]. Amendments to these three UN Regulations have been developed in the framework of the project “Study on enhanced sound requirements for mopeds, quads and replacement silencers of L-category vehicles related to enhanced sound requirements for L-category vehicles” (Papadimitriou et al., 2016) [41] and have been presented at the 64th GRB meeting, 5-7 September 2016. The aim was to perform due diligence on these regulations,



before considering their accession into the EU regulatory context. The focus was on improvements in the testing procedure and provisions for better market surveillance and enforcement, anti-tampering measures, and replacement exhaust silencing systems.

With Amendment 1 to revision 4 of Regulation 9 (category L₂, L₄ and L₅ vehicles) additional sound emission provisions were added to the regulation and will become mandatory in the future.

Table 3.2: Summary of UNECE TA sound test methods for L-vehicles

UN Regulation	TA Test method moving vehicle, sound limits	TA Test method stationary vehicle (for enforcement)	Approach speed
UN R9	L _{WOT} pass-by at 7,5m distance	L _{pAFmax} at 50 cm / 45° behind exhaust at specified engine speed + throttle release	minimum of: 50 km/h or the vehicle speed belonging to an engine speed of 3/4 of rated engine speed
UN R63	L _{WOT} pass-by at 7,5m distance	L _{pAFmax} at 50 cm / 45° behind exhaust at specified engine speed + throttle release	30 km/h or the max. vehicle speed if this is below 30 km/h
UN R41	L _{urban} , weighted average of L _{WOT} and L _{es} pass-by at 7,5m distance Also ASEP	L _{pAFmax} at 50 cm / 45° behind exhaust at specified engine speed + throttle release	40 km/h if PMR ≤ 50 50 km/h if PMR > 50

Recently the ASEP provisions have been revised in UNECE R41, 05 series of amendments. The differences with the current ASEP in R41-04 are set out in Table 3.3.

Table 3.3: Changes for new revision of ASEP for motorcycles, from GRBP ASEP 16th session June 2020

Changes compared to R41/04	R41-04 (current)	R41-05 (ASEP revision)
Speed range	20 – 80 km/h	10 – 100km/h (for PMR ≥ 150)
Max Rpm	3.4 * PMR-0.33 * (S – nidle) +nidle	0,8 x S (= increased)
Gears tested	Fixed gear (not including 1st)	Any gear (including 1st)
Throttle operation (between AA' & BB')	WOT only	Any constant throttle
Acceleration	WOT only	Any acceleration
Approach (pre AA')	Constant speed	Any approach (constant speed, acceleration, deceleration)
Number of test points	Reference points + 2 additional operating conditions	Reference points + [3 additional operating conditions / gear]
CVT	Exemption if requirements of §1.2 of Annex 7 are met.	No exemption



Regulation (EU) 134/2014 stipulates that the applicability of these UN Regulations is currently under revision, aiming to reference to the most recent versions of these UN Regulations and to align the mandatory application for EU type approval with the “Euro 5+” emission step.

3.2 TA Regulations for pollutant emissions

Emission standards for new mopeds and motorcycles have been in force since mid-1999, as outlined in Directive 97/24/EC. This directive initially established the Euro 1 standard, which was subsequently tightened twice for mopeds with the introduction of the Euro 2 (2002) and Euro 3 (2014) standards. For motorcycles, Euro 2 and Euro 3 were introduced in 2003 and 2006, respectively, as described in Directive 2002/51/EC. The emission legislation has been completely revised for the entire L-category, as detailed in Regulation (EU) 168/2013 and Delegated Regulation (EU) 134/2014. The updated legislation sets forth Euro 4 emission limits and procedures, which took effect in 2017, and Euro 5 limits, which became effective in 2020. The main developments of European emission regulations are summarized in Table 3.4.

Table 3.4: Key changes to emissions legislation L-category vehicles

Condition	Vehicle operation
Euro 2	- Mopeds and motorcycles: Lower emission limits compared to Euro 1.
Euro 3	- Mopeds: Emissions after cold start included in test results. - Motorcycles: Lower emission limits compared to Euro 2
Euro 4	- All L-category vehicles: o Lower emission limits compared to Euro 3 o Test procedure to control emissions from the crankcase. o Provision for evaporative emissions. o Lifetime requirements on emissions performance. o Test procedure to determine and report (electrical) energy consumption and CO2 emissions. o On-Board-Diagnostics (OBD) emission thresholds.
Euro 5	- All L-category vehicles: o Lower emission limits compared to Euro 4. o Emission limits the same for entire L-category, also largely the same as Euro 6 passenger cars. o Particulate matter standard also for direct-injection vehicles. o Heavier weighting of cold start emissions compared to Euro 4 o WMTC test cycle for all L-category vehicles. o Stricter OBD emission thresholds + focus on monitoring catalyst condition.



Emission limits are – just as the test procedure - an important part of emissions legislation. The table below lists the Euro 1 to 5 emission limits. For reference, the current Euro 6 emission standards for passenger cars are also included in the table. The upcoming Euro 5 emission limits for L-category vehicles have many similarities with the Euro 6 emission limits currently in place for passenger cars.

Table 3.5: Emission limits L-category vehicles relative to M1 vehicles

Stage	Category	Date	CO [mg/km]	HC [mg/km]	NO _x [mg/km]	HC + NO _x [mg/km]	PM [mg/km]	PN [#/km]
Euro 1	Mopeds	1999	6.000	-	-	3.000	-	-
	Motorcycles*	1999	13.000	3.000	300	-	-	-
Euro 2	Mopeds	2002	1.000	-	-	1.200	-	-
	Motorcycles**	2003	5.500	1000	300	-	-	-
Euro 3	Mopeds ³	2014	1.000	-	-	1.200	-	-
	Motorcycles	2006	2.000	300	150	-	-	-
Euro 4	Mopeds	2017	1.000	630	170	-	-	-
	Motorcycles***	2016	1.140	170	90	-	-	-
Euro 5	Complete L-category	2020	PI ⁴ : 1.000 CI ⁵ : 500	PI/CI: 100	PI: 60 CI: 90	-	PI****/CI: 4,5	-
Euro 6	Passenger cars	2014	PI: 1.000 CI: 500	PI: 100	PI: 60 CI: 80	CI: 170	PI****/CI: 4,5	PI/CI: 6,0*E11

* 4-stroke motorcycles | ** Displacement of ≥ 150 cm³ | *** Maximum speed of ≥ 130 km/h | **** Direct injection

Type approval driving cycles

As stated in Regulation (EU) No 168/2013, the revised Worldwide Harmonized Motorcycle Test Cycle (WMTC Stage 3) is to be used for type approval in accordance with Test Type I at the Euro 5 stage. At the Euro 4 stage, different driving cycles were used for certain categories, such as the ECE R40 and ECE R47 driving cycles (see Table 3.6). The revised WMTC, or WMTC Stage 3, is based on the original WMTC outlined in the UNECE Global Technical Regulation No 2 (GTR 2) and has been adapted for vehicles with a low maximum design speed, in compliance with Regulation (EU) No 134/2014. Different versions of the WMTC are therefore utilized for different vehicle categories, as shown in

³ The emission limit is the same as for Euro 2, however, for Euro 3, cold start emissions are also included.

⁴ PI: Positive Ignition, mainly gasoline engines.

⁵ CI: Compression Ignition, mainly diesel engines.



Table 3.7. According to Annex II, Appendix 6, Section (4), Paragraph 1 of Regulation (EU) No 134/2014, the same driving cycle at the Euro 5 stage applies to L4e, L5e-A, L7e-A, L7e-B, and L7e-C vehicles. The adapted WMTC has been introduced in the same regulation for L1e-A, L1e-B, L2e, L5e-B, L6e-A, and L6e-B subcategories, based on the reduced WMTC Part 1, where the speed profile of the cycle is further truncated to either 25 km/h or 45 km/h, depending on the maximum speed of each vehicle subcategory.

Table 3.6: Applicable driving cycle per vehicle category and Euro class [31]

Euro class	Test cycle	Vehicle category
Euro 4	ECE R47	L1e-A L1e_B L2e L6e-A L6e-B
	ECE R40	L5e-B L7e-B L7e-C
	WMTC, stage 2	L3e L4e L5e-A L7e-A
Euro 5	Revised WMTC	L1e - L7e

Table 3.7: WMTC vehicle classification per vehicle type [31]

WMTC class	Vehicle maximum design speed		Vehicle engine capacity		WMTC cycle
	min	max	min	max	
Class 1	-	< 100 km/h	-	< 150 cm ³	Part 1_R (2x)
Class 2-1	≥ 100 km/h	< 115 km/h	-	< 150 cm ³	Part 1_R + Part 2_R
	-	< 115 km/h	≥ 150 cm ³	≤ 1500 cm ³	
Class 2-2	≥ 115 km/h	< 130 km/h	-	≤ 1500 cm ³	Part 1 + Part 2
Class 3-1	≥ 130 km/h	< 140 km/h	-	≤ 1500 cm ³	Part 1 + Part 2 + Part 3_R
Class 3-2	≥ 140 km/h	-	-	> 1500 cm ³	Part 1 + Part 2 + Part 3

* 'R' = reduced

Table 3.8 summarizes the specifications of the driving cycles.



Table 3.8: Summary of the specifications of the cycles [31]

Cycle		Time	Expected distance	Average speed	Max speed	Idling	Constant speed	v*a positive	RPA	
		[sec]	[km]	[km/h]	[km/h]	[%]	[%]	[m2/s3]	[m/s2]	
Type I	WMTC	Class_1_reduced_25	1200	5.9	18	25	20	57	3.40	0.80
		Class_1_reduced_45	1200	7.6	23	45	19	27	3.72	0.60
		Class_1	1200	7.7	23	50	19	22	3.67	0.58
		Class_2_1	1200	12.3	37	83	13	24	5.23	0.54
		Class_2_2	1200	13.2	40	95	13	23	6.22	0.59
		Class_3_1	1800	27.6	55	111	9	30	6.73	0.54
		Class_3_2	1800	28.9	58	125	9	30	6.88	0.53
	ECE	R47_25	895	4.4	18	25	13	72	2.65	0.69
		R47_45	895	6.3	25	45	13	55	8.59	1.25
		R40_UDC	1169	6.0	19	50	32	29	3.66	0.64

Possible improvements after Euro 5

Lifetime emissions

To ensure low emissions over the entire lifetime of a vehicle, lifetime requirements have been included in the legislation since Euro 4. This means that the vehicle's emissions have to meet the Euro 4 or Euro 5 standard over the entire theoretical lifetime of the vehicle. Physical testing on the chassis dynamometer is one way to meet this requirement. The tests are carried out using a manufacturer-owned vehicle, which then drives the complete theoretical life cycle of the vehicle according to a durability drive cycle on the chassis dynamometer. Another option is to drive half this distance and extrapolate the emission results to the complete distance. A third option is to apply so-called "ageing factors", which range between 1.0 and 1.3 depending on the emission component. In practice, however, much larger deviations are measured [31]. Therefore, there is no guarantee of low lifetime emissions with this method. The study carried out investigated whether the physical tests are being performed. Up to now, it was found that manufacturers always opt for the ageing factors instead of the physical test. Based on the recommendations of the Euro 5 study [31] the ageing factors option had been removed from the legislation as of 2025.

For mopeds, the theoretical lifespan in legislation is set at 11,000 km, while the Euro 5 study estimated the actual lifespan to be 31,900 km. This means that if the test is carried out on the chassis dynamometer, it reflects only a limited part of the average life of a moped. For some motorcycle categories, the life expectancy in legislation also is on the low side, but this difference is not as substantial as for mopeds.

Testing with used vehicles from the market

Another way to ensure low emissions over the lifetime of the vehicle is to add In-Service-Conformity (ISC) testing to the type approval requirements. The aim of ISC is to test in-use vehicles by the same method as during initial type approval. Emissions should then still be below the limit, otherwise this could have consequences for the type approval certificate. For example, the Euro 5 study describes that mopeds in the market are often modified, which can worsen emissions performance. With current regulations (including Euro 5), such modifications are not detected. Applying ISC could reveal such modifications.

Testing on public roads



The implementation of new emissions directives requires significantly stricter exhaust emission requirements. The technology to make vehicles comply with these new requirements becomes more complex, and low emission levels will only be achieved if the advanced technology works well in real-world settings. While cars and trucks are already required to undergo on-road testing, emission measurements of L-vehicles still take place in the laboratory. Anecdotal evidence from the measurement campaign in Utrecht (the Netherlands) seems to suggest that maximum accelerations on the road are much higher than tested by the WMTC cycle, see Section 2.8. Therefore, it is recommended that more severe accelerations are include in future testing.

Measuring real-world emissions from L-vehicles on public roads can be an important method to validate this. For passenger cars and trucks, such measurements already take place, and equipment to measure L-vehicles on the road is currently being developed for wider deployment. Ideally, on-road testing should be carried out with used vehicles from the market, which would then be ISC road tests.

Tightening particulate emission requirements

Euro 5 introduces a particulate mass standard for L-category vehicles with direct injection or diesel engines. The Euro 5 study recommends the inclusion of a particulate matter standard for vehicles with a two-stroke engine as well, even though it is unlikely that any vehicles with two-stroke engines will meet the Euro 5 emission limits.

3.3 Comparison of TA with RW driving conditions assessment

3.3.1 Noise

As mentioned previously in section 2.1.2, the identified high noise events were observed at urban locations where resident complaints occur. In urban areas, there are typically many crossings, obstacles and dynamic vehicle conditions. For individual residents a limited set of conditions may occur. For example, near traffic lights, fast acceleration, engine revving and rpm drop-off and fluctuation may be the most noticeable conditions. In residential streets, engine startup and acceleration from standstill may be more common. Where the speed limit increases, such as entry to motorways or from smaller roads to trunk roads, noise from longer acceleration may be predominant. In rural areas, the predominant conditions may differ again, depending on the particular situation, such as winding roads, long straight roads or alpine passes and vehicle groups.

Around recreational locations such as tourist spots or entertainment venues, the extent and mix of the types of high noise events may also differ, for example including more engine revving, engine backfire and others associated with either driving behaviour, vehicle tampering or both.

One local survey was performed in parallel with the Dutch measurements in Amsterdam [37]. On the question of which noises are most disturbing, the following was indicated for three urban locations:

- suddenly increasing noise (engine speed)
- fluctuating noise (irregular revving and acceleration)
- fast acceleration at junctions
- revving during standstill



- high rpm die to late gear change
- rumbling noise.

Most of these identified high noise conditions are not covered by the UNECE regulations. R41 for motorcycles comes closest but only for acceleration conditions and within ASEP (UNECE R41.04) or RD-ASEP (UNECE R41.05). ASEP is restricted to 20-80 km/h and RD-ASEP is restricted to 10-100 km/h; engine speed is restricted in both. Maximum rpm, burst rpm, rpm drop-off or fluctuation are not included, neither are start from standstill conditions.

In addition, the WMTC cycle does not cover the high engine speeds that are characteristic for high noise conditions. According to UNECE GTR 2 the gear use and thus the engine speeds are determined following the gearshift prescriptions of the GTR. For a particular vehicle the upshift speed is a unique value for all gears higher than the first gear which has a slightly lower upshift speed. The upshift speed value is depending on the power to mass ratio of the vehicle as shown in the following figure.

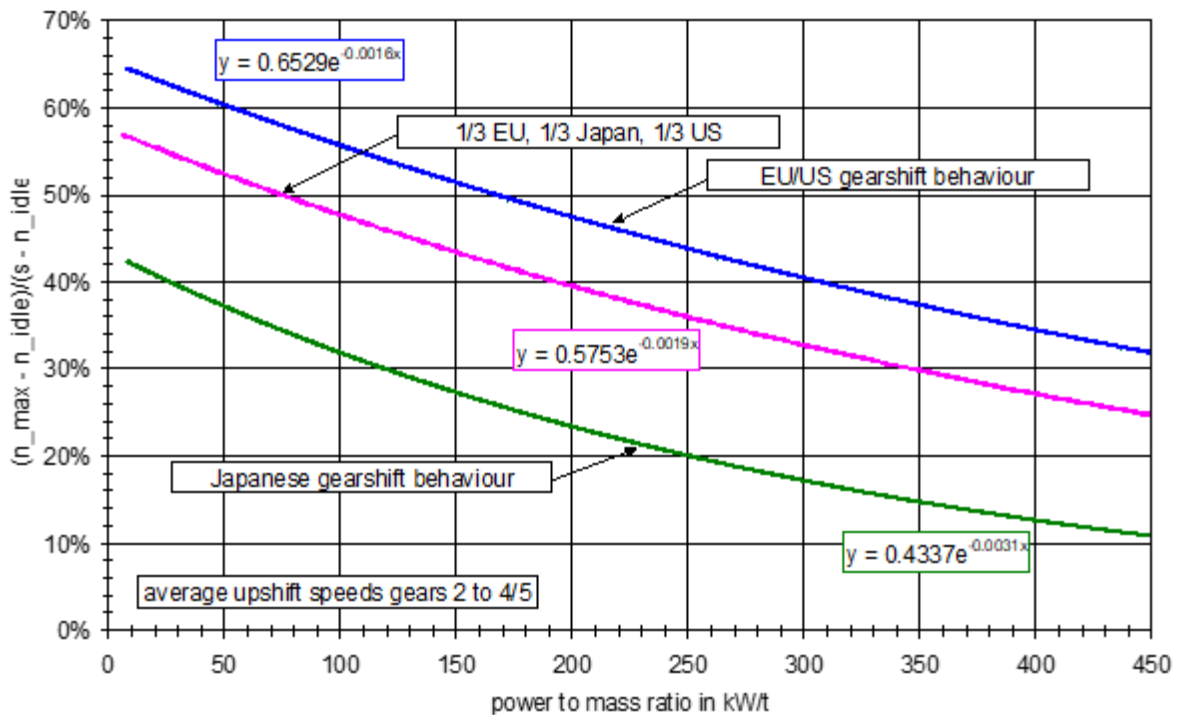

Figure 3-4: The final approximation function for upshift speeds in gears higher than 1 (1/3 Europe, 1/3 Japan, 1/3 USA). From ECE/TRANS/180/Add.2/Appendix 1 (Technical Report to GTR 2), s means rated engine speed

As one can see in Figure 3-4 the upshift speed approximation curve as function of the power to mass ratio was determined as compromise between the gear use in the regions Europe, Japan and the US based on in-use data from these regions. The approximation curves represent the upshift speeds in dependence of the power to mass ratio, normalised to the speed range between idling speed and rated speed. The upshift curve for Europe has about 8% higher normalised engine speed values than the WMTC curve.



On the UNECE website for GTR 2 an Excel calculation tool is provided that calculates the gear use and thus the engine speed for the WMTC cycle depending on the following input data for a particular vehicle:

- rated power
- kerb mass
- rated engine speed
- idling speed
- gear ratios in terms of engine speed in min⁻¹ divided by vehicle speed in km/h

The EU WMTC in-use database contains 7 vehicles of WMTC class 3-2, 2 vehicles of WMTC class 2-1 and 2 vehicles of class 1-3. The WMTC class 1-3 vehicles and one of the WMTC class 2-1 vehicle are scooters with CVT transmission whose engine speed values cannot be tested using the above mentioned calculation tool.

For the others this tool was used to calculate the engine speeds. For WMTC class 3-2 the vehicle with the lowest power to mass ratio in the EU WMTC in-use database (vehicle 3) was chosen. The results are

shown in the following figure. For WMTC class 3 vehicles all 3 parts of the WMTC cycle (low, medium, and high) are driven.

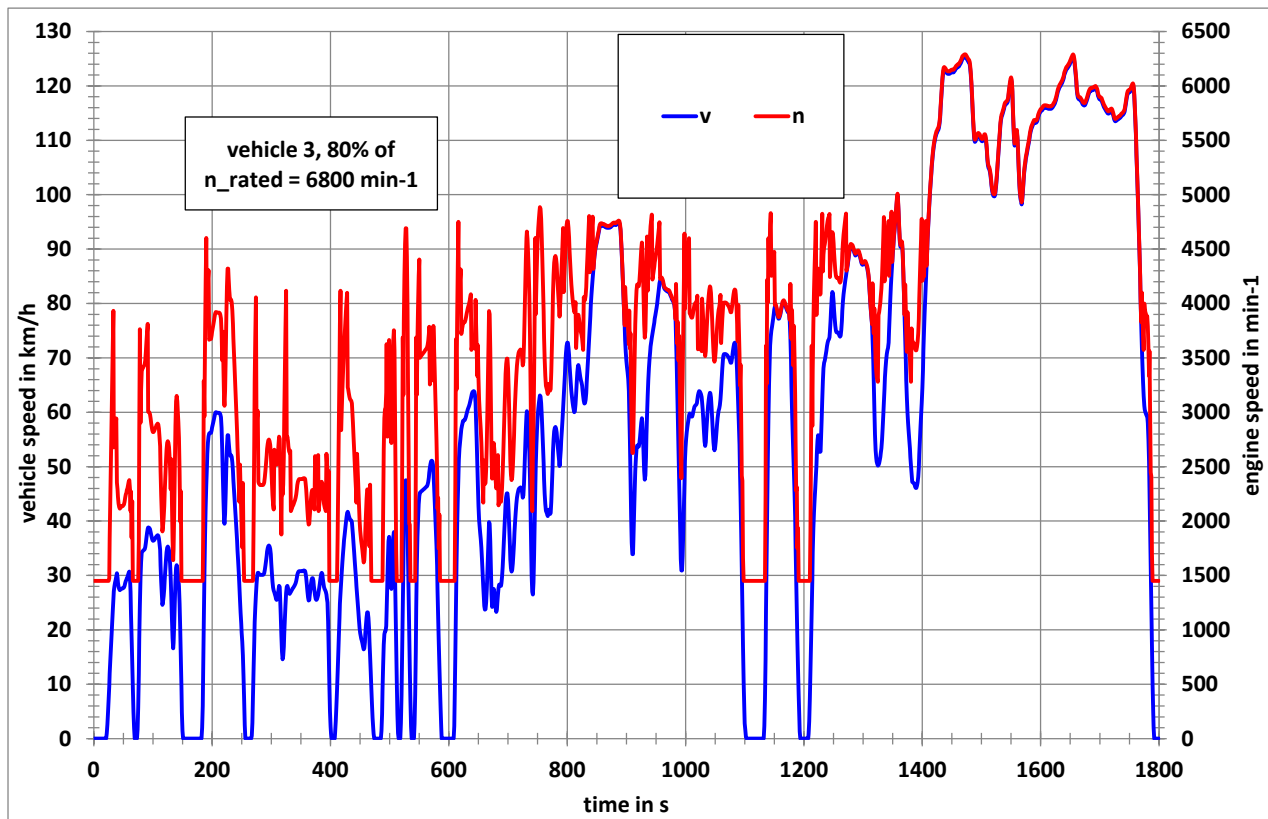

Figure 3-5: Vehicle and engine speed time series of the WMTC cycle for vehicle 3 of the EU WMTC in use database



As one can see in Figure 3-5, 80% of rated engine speed (6800 min⁻¹) -which was defined as threshold for noisy driving conditions- is never reached, even at maximum vehicle speed. And since the upshift speeds decrease with increasing power to mass ratio according to Figure , this will also be the case for the other vehicles in the EU WMTC in-use database.

Figure 3-6 shows engine speed versus vehicle speed plots for the WMTC cycle and WMTC in-use data for vehicle 3. In the in-use data the threshold of 6800 min⁻¹ is exceeded in gears 2 to 4 up to the maximum vehicle speed of the WMTC class 3-2 cycle (125.3 km/h). But this is related to the vehicle speed range between 70 km/h and the maximum speed of the WMTC cycle and thus to rural roads and motorways. In the speed range for urban streets the threshold is also not reached in the in-use data even if the vehicle would be driven in first and second gear only. That means noisy driving conditions are related to rural roads and motorways rather than urban streets.

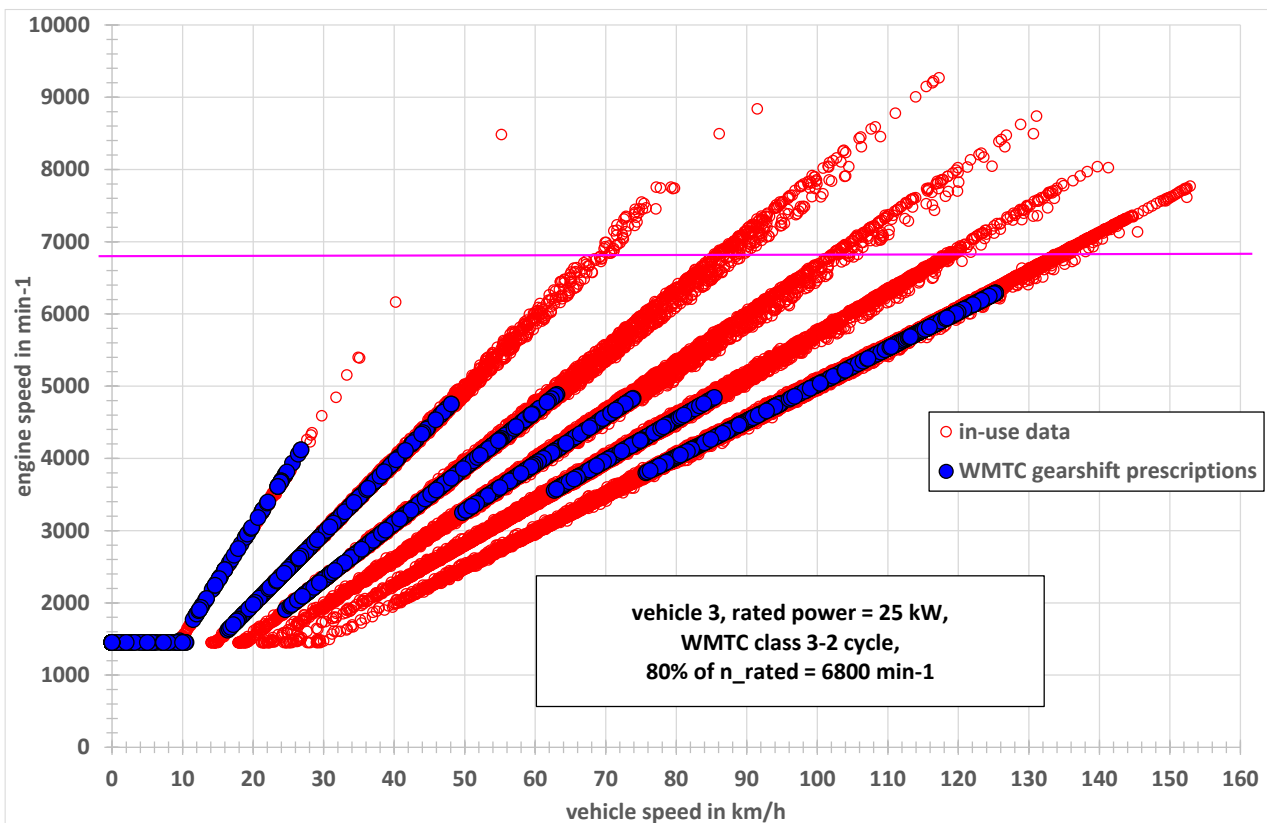

Figure 3-6: Engine speed versus vehicle speed plots for the WMTC cycle and WMTC in-use data for vehicle 3

Vehicle 37 from the EU in-use Database (engine capacity 150 cm³, rated power 11 kW and v_{max} 105 km/h) is a WMTC class 2-1 vehicle with manual transmission (Engine capacity ≥ 150 cm³ and $v_{max} < 115$ km/h). For this vehicle only the low and medium speed parts of the WMTC cycle is driven. The maximum speed of this cycle is 82.5 km/h.

The gear use and engine speed calculation results are shown in Figure 3-7.



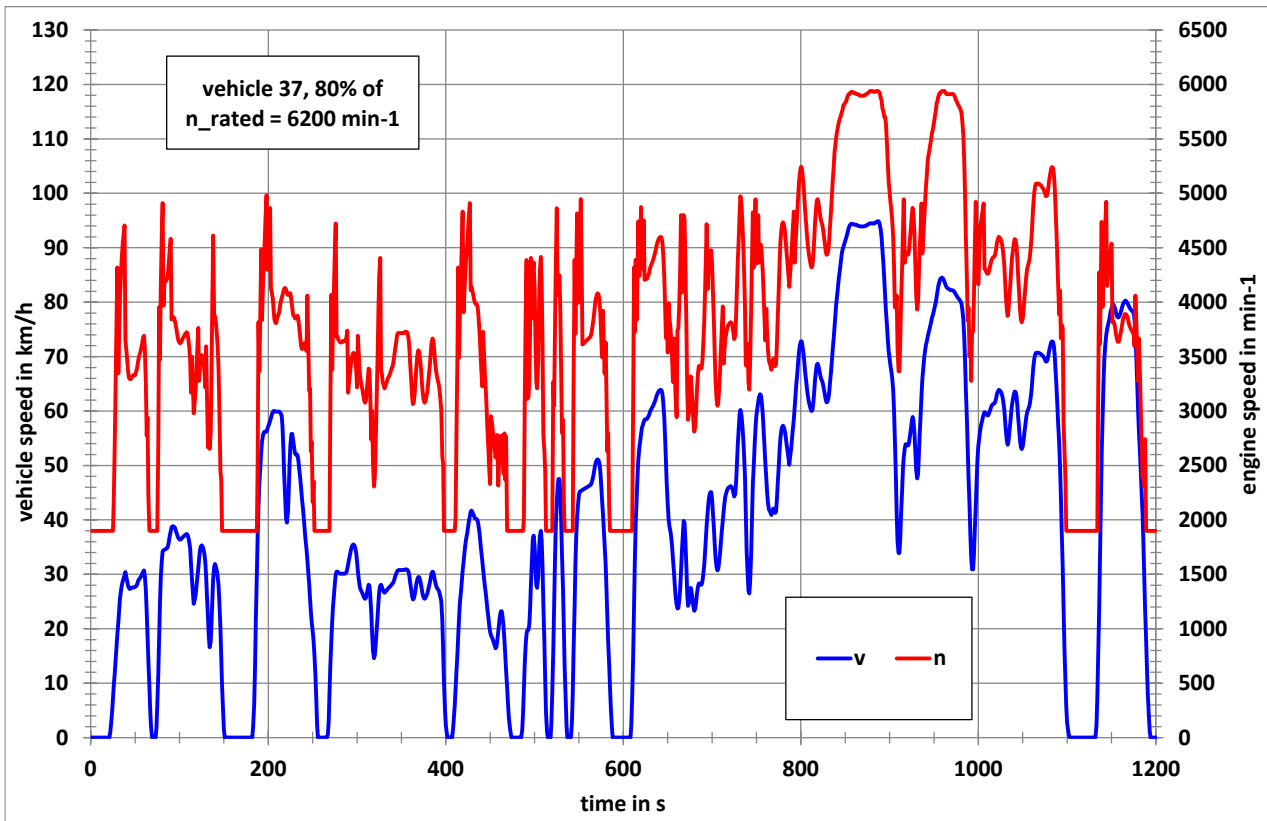

Figure 3-7: Vehicle speed and engine speed time series of the WMTC cycle for vehicle 37 of the EU WMTC in use database

Also, in this case the 80% rated engine speed threshold is never reached. But at high vehicle speeds the engine speed comes close to the threshold so that it cannot be excluded that the threshold will be exceeded for similar vehicles with lower rated power values.

Figure 3-8 shows engine speed versus vehicle speed plots for the WMTC cycle and WMTC in-use data for vehicle 37. In the in-use data the threshold of 6200 min^{-1} is exceeded in gears 2 to 4 up to the maximum vehicle speed of the WMTC class 2-1 cycle (82.5 km/h). The exceedance is related to the vehicle speed range between 40 km/h and the maximum speed of the WMTC cycle and thus includes also urban streets. That means the probability for noisy driving conditions in urban streets is higher for low powered motorcycles (including scooters) than for high powered motorcycles.



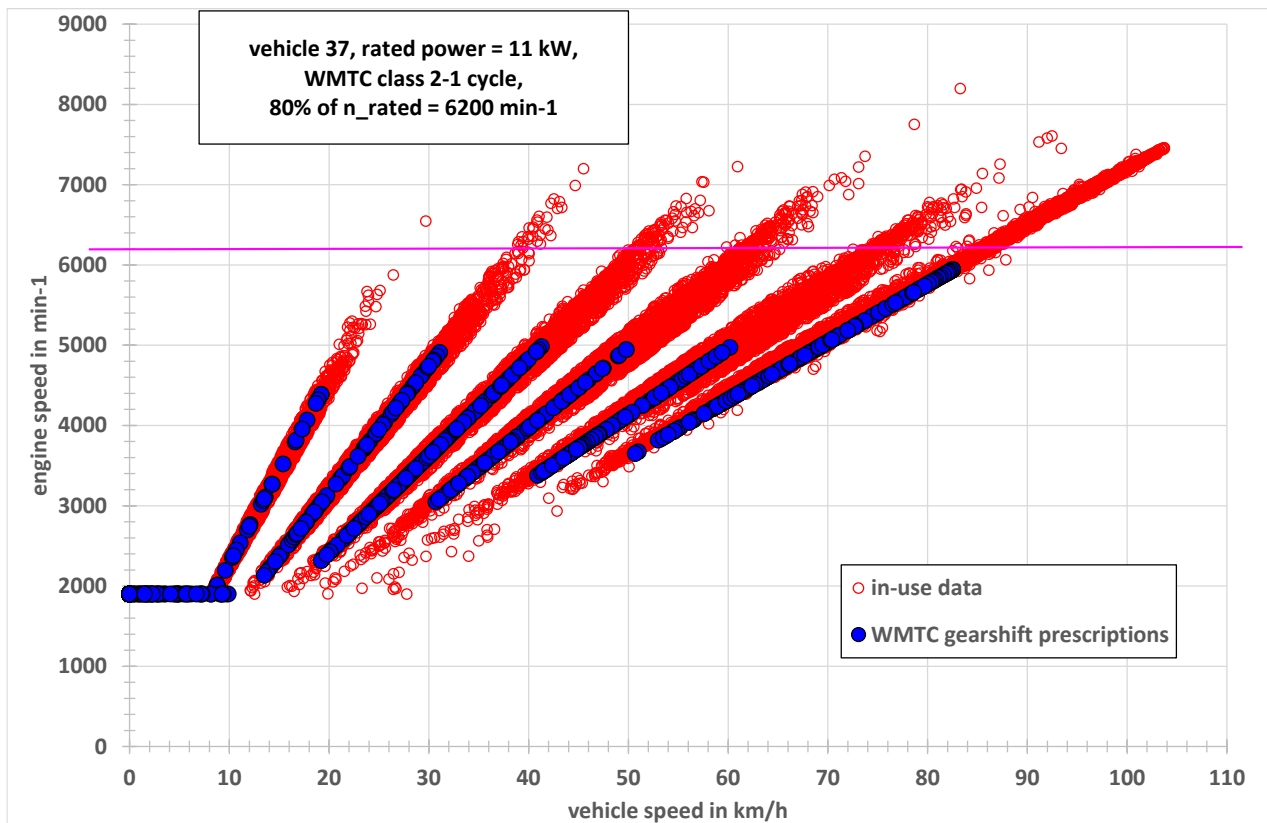

Figure 3-8: Engine speed versus vehicle speed plots for the WMTC cycle and WMTC in-use data for vehicle 37

A corresponding calculation for the three scooters in the EU WMTC in-use database cannot be performed because they have CVT transmissions. But also for these vehicles could be expected that the engine speed threshold of 80% of rated engine speed is not so often reached because the WMTC cycles have no high acceleration phases compared to the acceleration potential of the vehicles

3.3.2 Emissions

Cold start

Driving with a cold engine, leads to increased emissions compared to driving with a warm engine, as described in Chapter 2. The Euro 5 standard addresses this by weighting the emissions results of each part of the Worldwide Motorcycle Test Cycle (WMTC) separately. For mopeds and light L-category vehicles (speed <130 km/h), part 1 is weighted 50/50, which is the same as the average over the complete trip. (The weighing factors were different for Euro 4.) However, the total trip length is 1200 seconds, and the impact of the cold start is mainly felt in the first few seconds. Thus, the effect of the cold start is averaged out over a relatively large period. Further investigation is needed to determine the average trip length of L-category vehicles (relevant for the impact of cold start). For faster motorcycles (>130 km/h), the weighing factors are different, and part 1 of the test accounts for only 25% of the result, while its contribution in time is 1/3.



For the testing program it is recommended to assess the cold start impact separately from the rest of the test. The approach taken in the proposed Euro 7 legislation for passenger cars can be used as a basis for this. A possible solution to assess cold start emissions is by introducing an emission budget, like in Euro 7 is proposed for the first 10 km of the trip.

Driving at maximum speed

Driving a moped at maximum construction speed with full throttle may lead to elevated emissions and increased fuel consumption. This was found to be the case for mopeds with a carburetor, but it is not clear what the impact is for mopeds with electronic fuel injection. However, in real-world circumstances, wide open throttle operation is not uncommon for mopeds. The WMTC test cycle include little or no driving at maximum configuration speed for mopeds, as shown in Figure 3-9. This is also true for motorcycles, but clearly this is often not possible on public roads.

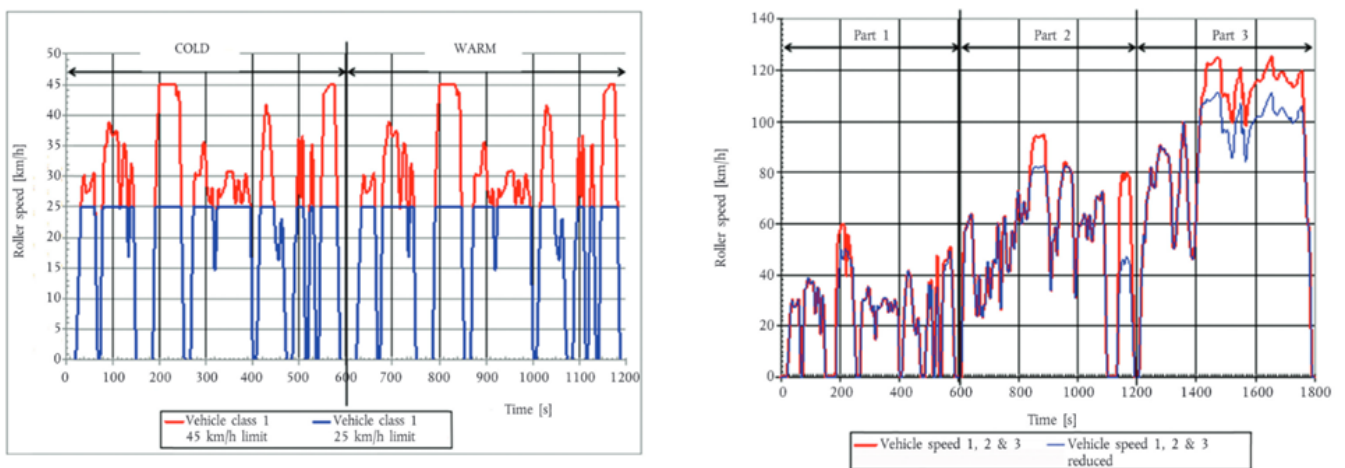

Figure 3-9: Vehicle speed time series of the WMTC cycle (left figure is for class 1 vehicles only)

Accelerations

As shown and described in Chapter 2, studies have shown that both mopeds and motorcycles produce elevated emissions during accelerations. The accelerations in the WMTC are not very demanding for most motorcycles. The R47 – for mopeds – included wide open throttle accelerations, in the WMTC wide open throttle is not prescribed and are such not necessarily included (only if the vehicle needs wide open throttle to follow the speed trace). The same is true for motorcycles, which may not be representative for real-world driving conditions. The anecdotal evidence from the measurement campaign in Utrecht seem to confirm this, see Section 2.8.

Reving and re-starting

During the WMTC, revving (increasing engine speed) and re-starting of the engine are not taken into account, even though these are conditions that may occur in real-world. The impact of these actions on emissions is not directly known, but it is important to consider them in the test program to get an accurate representation of real-world emissions. For example, some drivers may increase the engine

speed before take-off or after at a traffic light. Additionally, if the engine is turned off during a ride, the driver will need to restart it.

In-service vehicles

Chapter 2 highlights that some vehicles demonstrated high levels of emissions despite the engine being warm, indicating potential problems with the emission control system. During the type approval procedure, vehicles with a limited number of kilometres are usually tested, which may not accurately reflect their performance in real-world conditions. To obtain a more accurate understanding of a vehicle's emission performance, testing of in-service vehicles with higher mileage would be preferable.

Other conditions

A further evaluation is still required to cover missing conditions, for example:

- Testing at maximum technically permissible mass
- Stop and go testing simulating traffic congestion (idling and cold aftertreatment).



4 Conclusions and recommendations on requirements for the test programme

Considering the findings in the literature and the data analysis, and the evidence of the relevance of conditions critical for high noise and emission events, it is recommended to include these in the LENS test programme for both noise and pollutant emissions. For the on-road running tests and for testing on the test track or on a chassis dynamometer it should be straightforward to add these to a driving cycle. For controlled testing at the roadside or at a test facility, microphone positioning requires further specification. Both the conditions and measurement setup need to be clearly defined to provide comparable data.

4.1 Test vehicles

Based on the fleet data presented in this report, the test programme can be compared to evaluate how well the EU27 fleet is represented in the test programme. Moreover, it is recommended to use in-service vehicles from the market. In Regulation (EU) 2017/1151 for light-duty vehicles the minimum run-in mileage is 3.000 km. For “In-service-conformity” checks the mileage of light-duty vehicles should be between 15.000 and 100.000 km. For the test programme in this study, it is recommended that the in-service vehicles have a mileage of at least 3.000 km. For new vehicles, a mileage of at least 1.000 km is recommended, in line with Regulation 134/2014.

4.2 Critical events for noise measurement

Critical conditions

A list of critical conditions for noise has been identified, based on earlier roadside measurements of normal traffic at several urban locations, and validated in a new set of measurements in the city of Utrecht. These conditions have been shown to be mostly also relevant for emissions.

For the main test programme in LENS, it is recommended to include the proposed conditions where possible in the on road, test track and/or lab measurements. These can be combined in a succession in any of these three types of measurement. A suggestion for a series of these conditions is given in the following section.

As part of the test programme, it is recommended to include the identified relevant conditions in the tests for a certain number of vehicles. These are listed in Table 4.1. Most of these relevant conditions are not covered by the current TA regulations, mainly because those are focused on average driving conditions. Based on the results of the test programme, it will then be possible to evaluate how these could be used to improve the type approval regulations, and for some conditions potentially for the enforcement test.



Parameters to be measured

Engine speed is the predominant influence parameter for noise, followed by engine load.

Any test procedure intended to identify high noise events should therefore take these parameters into account. The following parameters are recommended to be measured in addition to the normal set, where possible in the test programme:

- engine speed as a function of time
- gear setting as a function of time
- weight of vehicle+driver (test mass).

Table 4.1: Recommended driving conditions for the noise test programme, ordered in possible test sequence

Condition	Vehicle operation	Short name	Already in noise TA?	Remarks
(1) Cold start (mainly for emissions)	Engine start	'coldstart'	No	
(2) rpm burst	Stationary, short activation and release of accelerator	'rpmburst'	No	From idling, 3x 50% max rpm
(3) Acceleration from standstill, G1, G2 Loaded + unloaded	Acceleration, late gear change	'rpmlongacc'	No	
(4) Max rpm passby esp. mopeds, scooters, sports MCs	Constant speed with max rpm	'rpmconthi'	No	
(5) Transition from constant speed or acceleration phases to deceleration phases	Deceleration	'rpmdropoff'	No	
(6) 'Max' acceleration from standstill, G1, G2	Acceleration	'rpmshortacc'	No	
(7) Acceleration at speed, from 50 to 100 kmh	Acceleration, may be varied	'rpmmidspeedacc'	MC: ASEP no, RD-ASEP yes	
(8) rpm fluctuation	Variable speed	'rpmfluct'	No	Accelerator intermittent
(9) Backfire (occurrence, distance not critical)	Multiple gear changing or manual operation	'bang'	No for R41.04. R41.05 measurement covers deceleration phase	Condition at which backfire would be most likely

4.3 Critical events for pollutant emission measurements

As part of the LENS test programme, it is recommended to include the identified high emission conditions in the tests for a certain number of vehicles, ideally during on-road measurements by using SEMS or PEMS equipment. Most of the conditions are not covered by the current TA test procedures. There is an overlap with the conditions for noise. However, for emissions it is recommended to implement these conditions in the driving cycle (ideally on the road), not in a road side measurement.

The most important conditions with potential elevated emissions are listed in [Table 4.2](#). In addition, some elements could not be evaluated due to a lack of data, but may lead to increased emissions, these are:

- Restarting during the test;
- Testing at maximum technically permissible mass;
- Stop and go testing simulating traffic congestion (idling and cold aftertreatment).

It is recommended to include these conditions in the LENS test programme. For emission measurements, these conditions can be integrated in the on-road measurement campaign.

Parameters to be measured

Important parameters (in addition to the emissions) which should be measured during the test programme are:

- Weight of vehicle+driver (Test mass)
- Vehicle speed as a function of time
- Engine speed as a function of time
- Gear setting as a function of time
- Exhaust gas temperature as a function of time

For the testing program it is recommended to assess the cold start impact separately from the rest of the test. The approach taken in Euro 7 legislation proposal can be used as a basis for this. A possible solution to assess cold start emissions is by introducing an emission budget, like proposed in Euro 7 for the first 10 km of the trip.



Table 4.2: Recommended driving conditions for the tailpipe emissions programme, ordered in possible test sequence.

Condition	Vehicle operation	Short name	Already in emission TA?	Remarks
(1) Cold start (mainly for emissions)	Engine start	'coldstart'	Yes	Emission budget?
(2) rpm burst (revving)	Stationary, short activation and release of accelerator	'rpmburst'	No	From idling, 3x 50% max rpm
(3) Acceleration from standstill, G1, G2 Loaded + unloaded	Acceleration, late gear change	'rpm longacc'	Partly	
(4) Max rpm; esp. mopeds, scooters, sports MCs	Constant speed with max rpm	'rpmconthi'	No	Mopeds: Wide Open Throttle
(5) Transition from constant speed or acceleration phases to deceleration phases	Deceleration	'rpm dropoff'	Partly	
(6) 'Max' acceleration from standstill, G1, G2	Acceleration	'rpm shortacc'	No	Sportive and dynamic driving
(7) (Strong) Acceleration at speed, from 50 to 100 km/h	Acceleration, may be varied	'rpm midspeedacc'	No	
(8) rpm fluctuation	Variable speed	'rpmfluct'	No	Accelerator intermittent – dynamic driving
(9) Backfire (occurrence, distance not critical)	Multiple gear changing or manual operation	'bang'	No	Condition at which backfire would be most likely



5 References

- [1] UNECE R40, 1979. *Regulation No. 40, Uniform Provisions Concerning the Approval of Motorcycles Equipped with a Positive -Ignition Engine with Regard to the Emission of Gaseous Pollutants by the Engine*. <https://www.unece.org/fileadmin/DAM/trans/main/wp29/wp29regs/r040e.pdf>: s.n.
- [2] UNECE R47, 1981. *Regulation No. 47, Uniform Provisions Concerning the Approval of Mopeds Equipped with a Positive -Ignition Engine with Regard to the Emission of Gaseous Pollutants by the Engine*. <https://www.unece.org/fileadmin/DAM/trans/main/wp29/wp29regs/r047e.pdf>: s.n.
- [3] UN GTR No. 2 - *Measurement procedure for two-wheeled motorcycles equipped with a positive or compression ignition engine with regard to the emission of gaseous pollutants, CO2 emissions and fuel consumption* (ECE/TRANS/180/Add.2) - Technical report describing the data analysis and the development work for UN GTR No.2
- [4] Appendix to UN GTR No. 2 - *Proposal to develop a UN Global Technical Regulation concerning worldwide motorcycle emissions test cycle and Report on the development of a global technical regulation concerning worldwide harmonized motorcycle emissions certification procedure* (ECE/TRANS/180/Add.2/Appendix 1)
- [5] Regulation (EU) no 168/2013 of the European Parliament and of the Council of 15 January 2013 on the *approval and market surveillance of two- or three-wheel vehicles and quadricycles* (Refers to WMTC and revised WMTC, and ECE R47 + ECE R40)
- [6] Regulation (EU) 134/2014, amendment to 168/2013.
- [7] Commission Delegated Regulation (EU) 2018/295 of 15 December 2017 amending Delegated Regulation (EU) No 44/2014, as regards vehicle construction and general requirements, and Delegated Regulation (EU) No 134/2014, as regards environmental and propulsion unit performance requirements for the approval of two- or three-wheel vehicles and quadricycles
- [8] UNECE Regulation 63 rev 2, *Uniform provisions concerning the approval of two-wheeled mopeds with regard to noise*, November 2013
<https://unece.org/fileadmin/DAM/trans/main/wp29/wp29regs/2013/R063r1e.pdf>
- [9] UNECE Regulation 41 rev2 04 series of amendments, *Uniform provisions concerning the approval of motorcycles with regard to noise*
<https://unece.org/fileadmin/DAM/trans/main/wp29/wp29regs/R041r2e.pdf>
- [10] UNECE Regulation 9 rev2 07 series of amendments
Uniform provisions concerning the approval of category L2, L4 and L5 vehicles with regard to noise, 3 November 2013 <https://unece.org/DAM/trans/main/wp29/wp29regs/2015/R009r3e.pdf>
- [11] UNECE Regulation No. 92 Rev1 - Amendment 3, 02 series of amendments
Replacement exhaust silencing systems for motorcycles, 15 October 2019
<https://unece.org/sites/default/files/2021-05/R092r1am3e.pdf>
- [12] IMMA, *ECE R41 Revision, Outline of main modules with reference to draft amending text*, Informal document no. GRB-47-11, Presentation by Draft Expert Group to R41WG, 19 February 2008, Agenda item 2.
<https://unece.org/DAM/trans/doc/2008/wp29grb/ECE-TRANS-WP29-GRB-47-inf11e.pdf>
- [13] IMMA, *UN-R41.04 ASEP Overview*, R51 ASEP IWG, 11-13 July 2017
- [14] IMMA, *R41 ASEP Revision*, Informal document GRBP-71-19-Rev.1, 71st GRBP, 28-31 January 2020, agenda item 2 <https://unece.org/DAM/trans/doc/2020/wp29grb/GRBP-71-19e-Rev.1.pdf>
- [15] Informal group on motorcycle noise emissions (Regulation No. 41), development of draft Proposal for draft 04 series of amendments to Regulation No. 41 (Noise of motorcycles, including ASEP requirements) - UNECE GRBP IWG R41
- [16] German Environment Agency, *Determination of Noise Emission Values from Motorcycles on the Basis of Practical Driving Collectives (In-use driving behaviour data collection including noise emission)*, Heintz Steven, FIGE GmbH, 1984



- [17] German Environment Agency, *Minderung der Lärmemission von motorisierten Zweirädern*, Brendicke et.al., 1998
- [18] German Environment Agency, *Development of a new driving cycle for the type approval test concerning exhaust emissions for motorcycles and calculation of emission factors of motorcycles as well as the development of a noise test procedure under load as a part of the future periodical exhaust and noise emission*, Heinz Steven, TÜV Automotive, 2000
- [19] German Environment Agency, *Determination of Noise Emission Levels for a Selection of Replacement Silencers for Motorcycles*, Heinz Steven, TÜV Nord Mobilität, 2006
- [20] UNECE GRPE IWG WMTC, *Technical report for the development of the WMTC*, Heinz Steven, 2004
- [21] H. Steven, *Worldwide Harmonised Motorcycle Emissions Certification Procedure*
UN/ECE-WP 29 – GRPE, WMTC Working Group, 2003
<https://unece.org/DAM/trans/doc/2003/wp29grpe/TRANS-WP29-GRPE-45-inf09e.pdf>
- [22] B.Giechaskiel, A.Zardini & G.Martini, *Particle Emission Measurements from L-Category Vehicles*, s.l.: SAE International, 2015.
- [23] Giechaskiel, B., Vanhanen, J., Väkevä, M. & Martini, G., 2017. Investigation of vehicle exhaust sub-23 nm particle emissions. *Aerosol Science and Technology*.
- [24] Giechaskiel, B., Zardini, A. & Martini, G., 2015. Particle Emission Measurements from L-Category Vehicles. *SAE Int. J. Engines*, doi: 10.4271/2015-24-2512, 8(5), p. 2322–2337
- [25] Hensema, A., Mensch, P. v. & Vermeulen, R., 2013. *Tail-pipe emissions and fuel consumption of standard and tampered mopeds*, Delft: TNO.
- [26] Stephan van Zyl, Pim van Mensch, Norbert Ligterink, Rianne Dröge, Gerrit Kadijk, 2015. *Update emission model for two-wheeled mopeds*, Utrecht, The Netherlands: TNO Report 2014 R11088.
- [27] Vasic, A.-M. & Weilenmann, M., 2006. *Comparison of Real-World Emissions from Two-Wheelers and Passenger Cars*. *Environmental Science and Technology*, 40(1), pp. 149-154.
- [28] Emissions of two-wheeled vehicles, TNO report, TNO-060-UT-2011-01556, Rianne Dröge, Amber Hensema, Harm ten Broeke, Jan Hulskotte
- [29] Arjan Eijk, Pim van Mensch, Mitch Elstgeest, *Tailpipe emissions of mopeds in the Dutch fleet*, TNO report, 8 December 2017.
- [30] T.J. Barlow et al, *A reference book of driving cycles for use in the measurement of road vehicle emissions*, TRL report, 2009
https://assets.publishing.service.gov.uk/government/uploads/system/uploads/attachment_data/file/42471/ppr-354.pdf
- [31] Ntziachristos, L., Vonk, W., Papadopoulos, G., van Mensch, P., Geivanidis, S., Mellios, G., Papadimitriou, G., Elstgeest, M., Ligterink, N., Kontses, A., 2017. *Effect study of the environmental step Euro 5 for L-category vehicles*. Final report of EC DG GROWTH project 060.18277, May 2017.
- [32] ASEP-16-03 (Germany) *Resolution of the Federal Council 125-20 about Motorcycle Noise*, 15 May 2020
- [33] C. Lechner, D. Schnaiter, U. Siebert, S. Böse-O'Reilly, *Effects of Motorcycle Noise on Annoyance—A Cross-Sectional Study in the Alps*, *International Journal of Environmental Research and Public Health*, 29 February 2020.
- [34] C. Lechner, D. Schnaiter, *Motorradlärmmstudie Außerfern 2019 Gesamtbericht*
<https://www.tirol.gv.at/arbeit-wirtschaft/esa/laerm/motorradlaermstudie-2019/>
- [35] Paviotti, M., Vogiatzis, K., *On the outdoor annoyance from scooter and motorbike noise in the urban environment*. *Science of the Total Environment*, vol. 430, 2012, pp. 223-230.
- [36] M.G. Dittrich, P.J.G. van Beek, E.Salomons,
Beleidsopties voor de aanpak van geluidhinder door gemotoriseerde tweewielers (Policy options for reducing noise annoyance due to motorcycles, mopeds and scooters)
TNO Report TNO 2020 R11995, December 2020
<https://www.tweedekamer.nl/downloads/document?id=2023D11440>
- [37] M.G. Dittrich, P. Wessels, F. Staats, *Monitoring luide voertuigen in Amsterdam (Monitoring of loud vehicles in Amsterdam, in Dutch)*, TNO report ref. TNO 2022 R10053, January 2022
<https://openresearch.amsterdam/en/page/84173/rapport-tno-monitoring-luide-voertuigen-in-amsterdam>



- [38] M.G. Dittrich, P. Wessels, F. Staats, *Monitoring luide voertuigen in Rotterdam (Monitoring of loud vehicles in Rotterdam, in Dutch)*, TNO report ref. TNO 2023 R10157, March 2023
- [39] M.G. Dittrich, P. Wessels, F. Staats, *Monitoring luide voertuigen in Den Haag (Monitoring of loud vehicles in The Hague, in Dutch)*, TNO report ref. TNO 2023 R10459, May 2023.
- [40] M.G. Dittrich, P. Wessels, F. Staats, *Monitoring luide voertuigen in Utrecht (Monitoring of loud vehicles in Utrecht, in Dutch)*, TNO report, October 2023
- [41] Papadimitriou, G., Ntziachristos, L., Steven, H., Dittrich, M., *Study on enhanced sound requirements for mopeds, quads and replacement silencers of L-category vehicles*. Final report of EC DG GROW project 2015.5724, Oct. 2016. doi: 10.2873/054474.
- [42] Papadimitriou, G., Ntziachristos, L., Durampart, M., Dittrich, M., Steven, H., *Study on Euro 5 sound level limits of L-category vehicles*, Final Report for European Commission, November 2017, ISBN 978-92-79-70064-4.
- [43] C. Huth, G. Eberlei, M. Liepert, *Überprüfung der Geräuschemissionen von Motorrädern im realen Verkehr*, Abschlussbericht, Möhler + Partner Ingenieure AG, 86153 Augsburg, September 2020.
<https://www.umweltbundesamt.de/publikationen>
- [44] Alessandro A. Zardini, Stephen M. Platt, Michael Clairotte, Imad El Haddad, Brice Temime-Roussel, Nicolas Marchand, Irena Ježek, Luka Drinovec, Griša Močnik, Jay G. Slowik, Urbano Manfredi, André S.H. Prévôt, Urs Baltensperger, Covadonga Astorga, *Effects of alkylate fuel on exhaust emissions and secondary aerosol formation of a 2-stroke and a 4-stroke scooter*, Atmospheric Environment, Volume 94, 2014, Pages 307-315
- [45] <https://www.emisia.com/utilities/copert-data/>
- [46] <https://www.gecoair.fr/en/>



Annex A Overview of L-category vehicles

Vehicle categorisation	Typical Photos of Models			Key specifications
L1e - A Powered cycle				≤50 cc (PI), ≤25 km/h, ≤1 kW
L1e - B Two-wheel moped				≤50 cc (PI), ≤45 km/h, ≤4 kW
L2e Three-wheel moped	 L2e-P	 L2e-U		≤50 cc (PI) / ≤500 cc (CI), ≤45 km/h, <4 kW, ≤270 kg
L3e Two-wheel motorcycle	 L3e-A1	 L3e-A2	 L3e-A3	A1: ≤125 cc, ≤11 kW, ≤0.1 kW/kg A2: ≤35 kW, ≤0.2 kW/kg A3: >35 kW, >0.2 kW/kg
L4e Two-wheel motorcycle with side-car				Equivalent to the corresponding L3e
L5e - A Tricycle				3 wheels, ≤1000 kg, max 5 seats
L5e - B Commercial tricycle				3 wheels, ≤1000 kg, max 2 seats, loading volume ≥ 0.6m ³
L6e - A Light on-road quad				≤50 cc (PI) / ≤500 cc (CI), ≤45 km/h, ≤4 kW, ≤425 kg
L6e - B Light quadri-mobile	 L6e-BP	 L6e-BU		≤50 cc (PI) / ≤500 cc (CI), ≤45 km/h, ≤6 kW, ≤425 kg
L7e - A Heavy on-road quad	 L7e-A1	 L7e-A2		≤15kW, ≤450 kg
L7e - B Heavy all terrain quad	 L7e-B1	 L7e-B2		B1: ≤90 km/h, ≤450 kg B2: ≤15kW, ≤450 kg
L7e - C Heavy quadri-mobile	 L7e-CU	 L7e-CP		CU: ≤90 km/h, ≤15kW ≤600 kg CP: ≤90 km/h, ≤15kW ≤450 kg

Figure A-1: L-vehicle types Source: [31]



Annex B Examples of sound characteristics

B1 Examples of sound characteristics of high noise events of several L-vehicles

The vehicle sound data shown in the following are from roadside traffic monitoring performed by TNO in Amsterdam, Rotterdam, and The Hague in 2021-2022, and in Utrecht in 2023. For more details see refs [37][38][39][40]. The measurements from Utrecht also included an additional microphone and radar for LENS shown in part B2 of this annex.

The sound label type is included in the figure captions, being based on the change of engine harmonics in time, best visible in the narrowband spectrogram upto 1000 Hz. Although a single sound label is attributed, more than one may be applicable in some cases.

Key to the figures:

- Top left: time signal of the sound pressure at the roadside for 20 second interval.
- Centre left: A-weighted and unweighted sound level history for 20 second interval.
- Top centre: one third octave spectrum and octave spectrum of the maximum sound pressure level and of the equivalent sound pressure level over 4 seconds.
- Centre: narrowband spectrum of maximum and average spectrum over 4 seconds.
- Top right: spectrogram in one third octave bands for 20 seconds.
- Centre right: narrowband spectrogram upto 1000 Hz for 20 seconds.
- Bottom left: Acoustic parameters and features.
- Bottom centre: vehicle data derived from registration number.
- Bottom right: anonymised image of vehicle.



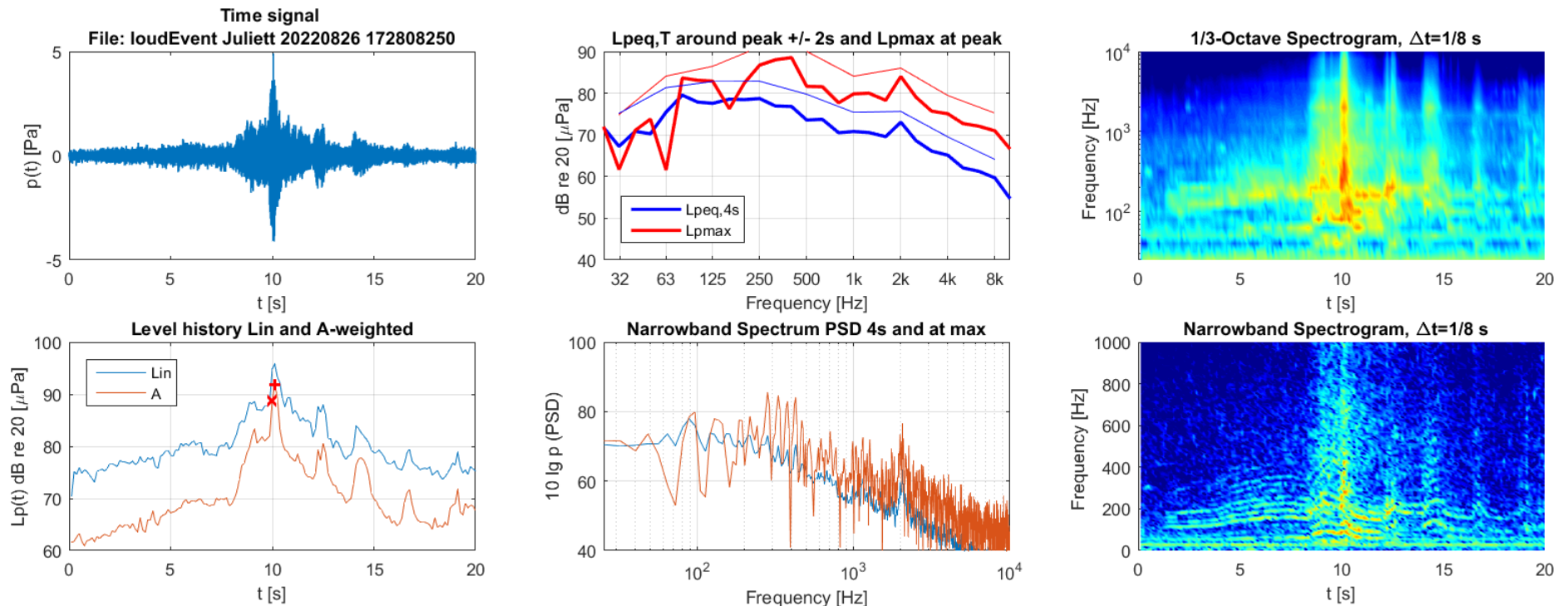

Sound characteristics

LpAmax= 92 dBA Lpmax= 96dB tamax10=0.75s
 Llin-LA= 4dB(max) Llin-LA= 6dB(eq) dLpAmaxeq= 10dB
 SELA(4s)= 88dBA LpAeq4s= 82dBA maxpeakprom= 6
 Prom20= 24dB Prom4s= 17dB Max risetime= 54dB/s
 Peak freqs @ 50 80 2000
 Levels at peak freqs= 74 84 84
 Strongest freq peak @2000Hz dLpmaxLMH= -7 -2 -9 dB
 Sound indicator= engine v bangs
 Sound label= rpmburst

Vehicle data

2022-08-26 19:28:08.250 locWW Dir:West
 3W
 POLARIS SCRAMBLER XP 850 H.O
 Petrol 850cc 2 cyl 415 kg 15 kW 4 wheels
 40 km/h First reg. 05/2013
 PB level: 80dBA ST level: 91dBA
 Event#663(mid#108) Reg#3067



Figure B-1: Sound characteristics of a quad, example of 'rpmburst'



This project has received funding from the European Union's Horizon Europe research and innovation programme under grant agreement No 101056777

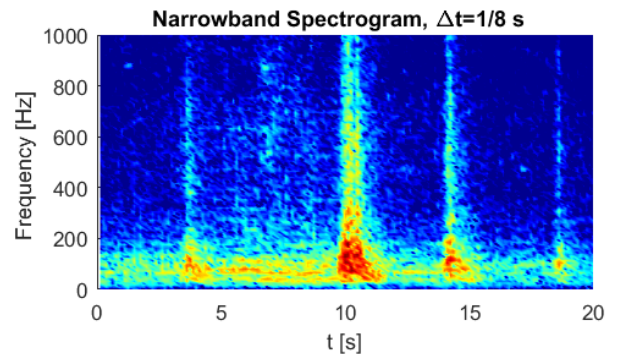
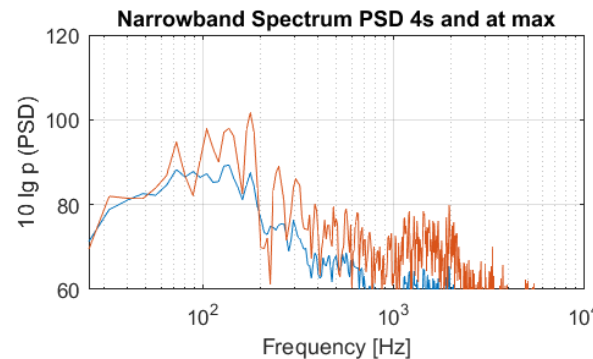
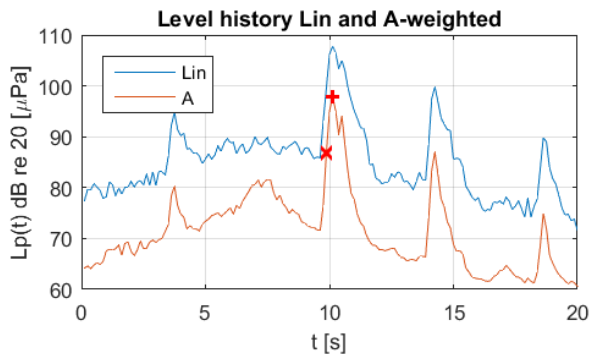
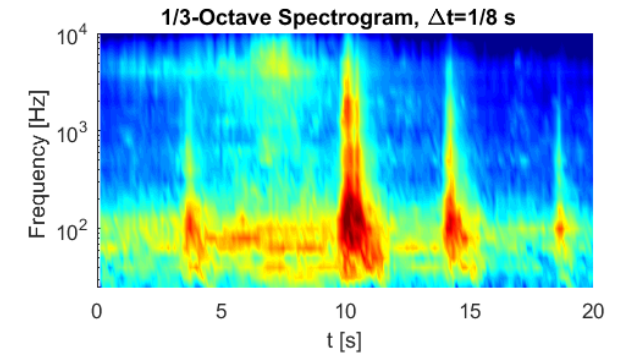
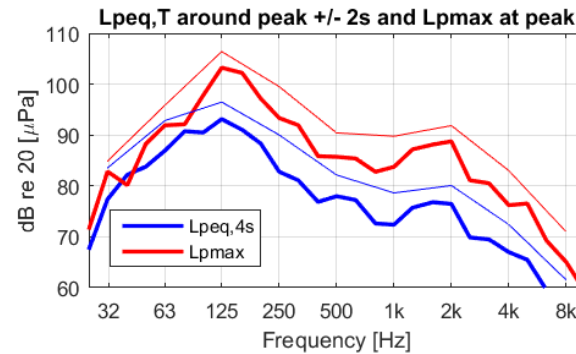
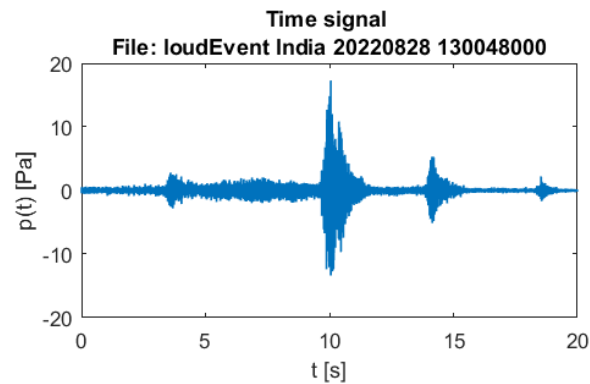

Sound characteristics

LpAmax= 98 dBA Lpmax=108dB tamax10=0.75s
 Llin-LA= 10dB(max) Llin-LA= 12dB(eq) dLpAmaxeq= 10dB
 SELA(4s)= 94dBA LpAeq4s= 87dBA maxpeakprom= 32
 Prom20= 26dB Prom4s= 17dB Max risetime= 82dB/s
 Peak freqs @125 2000
 Levels at peak freqs=103 89
 Strongest freq peak @125Hz dLpmaxLMH= -1 -7 -15 dB
 Sound indicator= engineL
 Sound label= rpmburst

Vehicle data

2022-08-28 15:00:48.000 locWW Dir:West
 Motorcycle
 HARLEY DAVIDSON CVO ULTRA LIMITED
 Petrol 1923cc 2 cyl 428 kg 78 kW 2 wheels
 30 km/h First reg. 09/2021

PB level: 76dBA ST level: 92dBA
 Event#325(mid#866) Reg#17161



Figure B-2: Sound characteristics of a motorcycle, example of 'rpmburst'



This project has received funding from the European Union's Horizon Europe research and innovation programme under grant agreement No 101056777

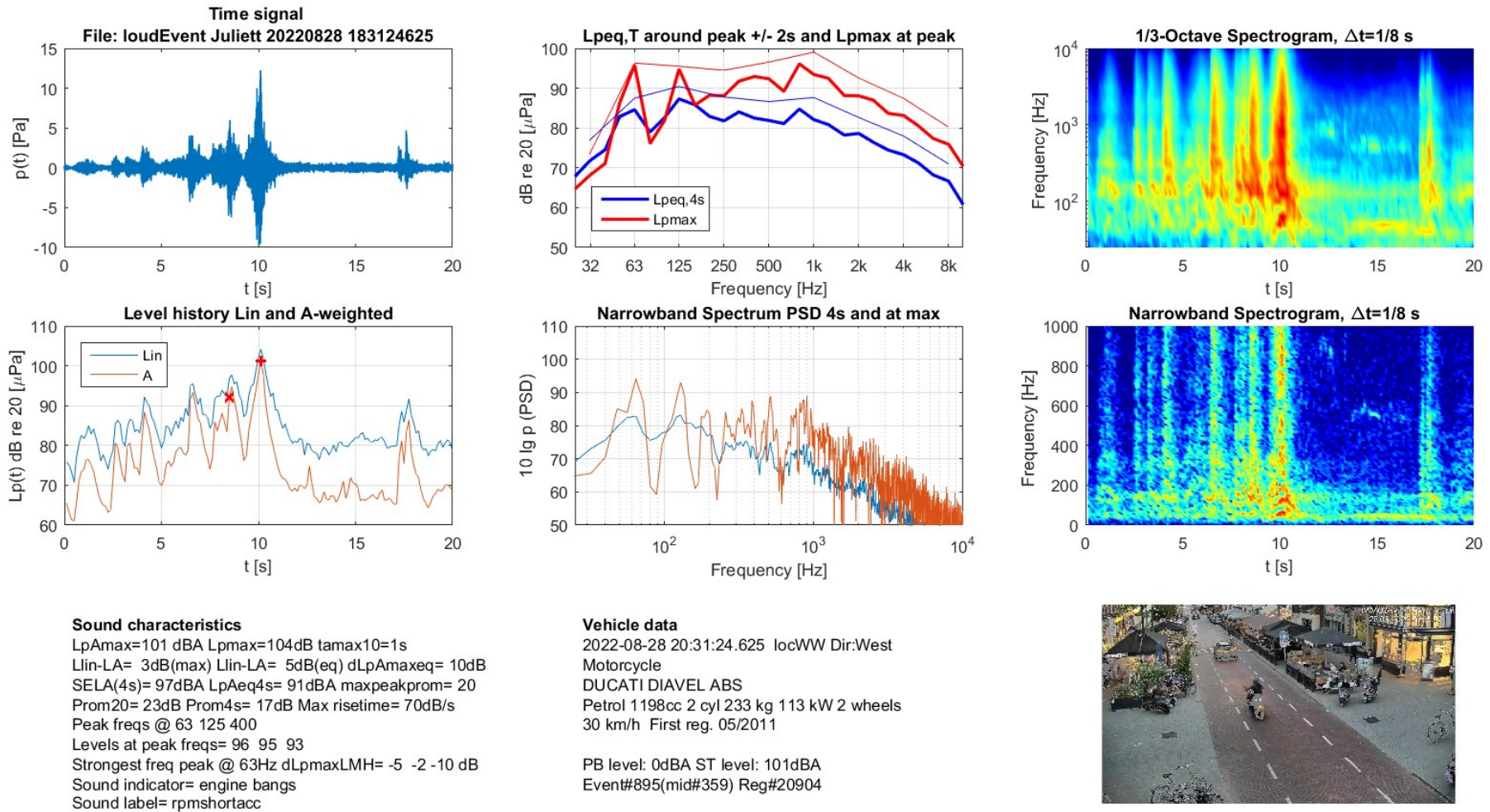

This project has received funding from the European Union's Horizon Europe research and innovation programme under grant agreement No 101056777

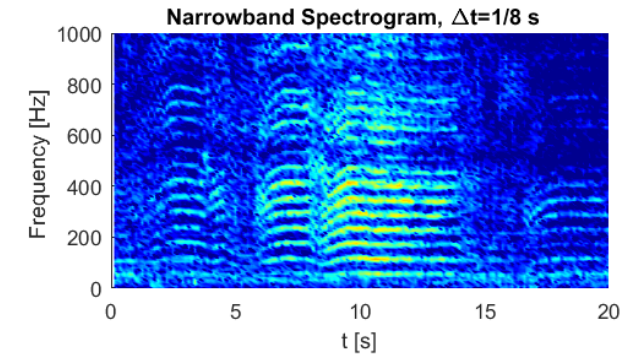
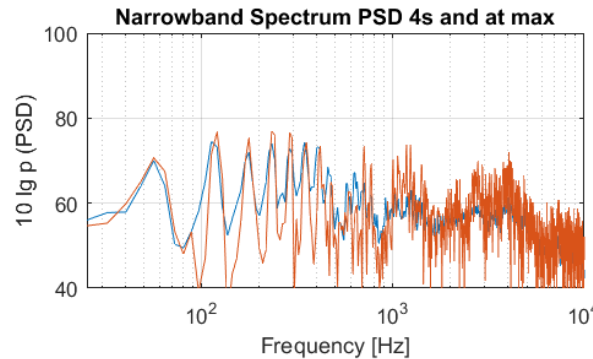
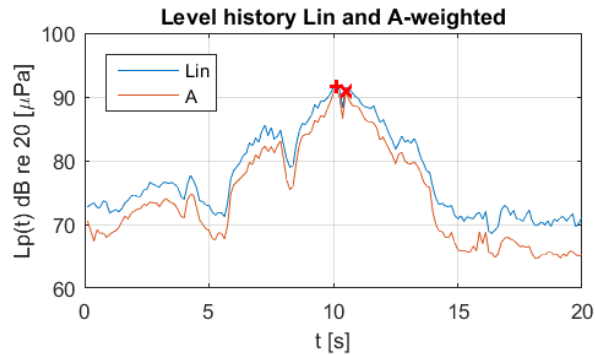
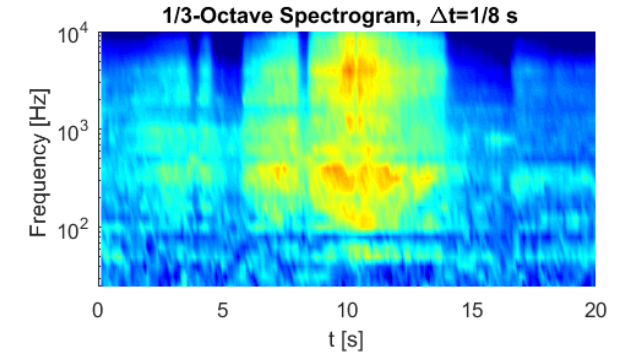
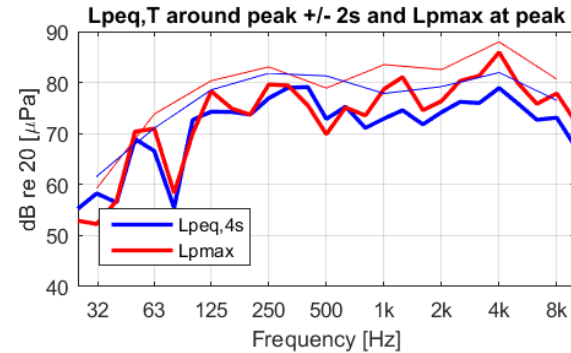
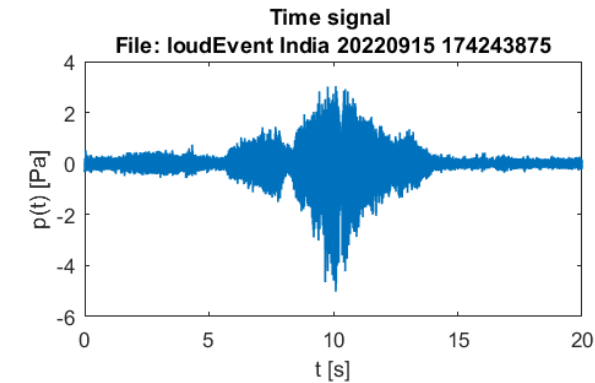

Sound characteristics

LpAmax= 92 dBA Lpmax= 92dB tamax10=4.375s
 Llin-LA= 0dB(max) Llin-LA= 2dB(eq) dLpAmaxeq= 5dB
 SELA(4s)= 93dBA LpAeq4s= 87dBA maxpeakprom= 14
 Prom20= 20dB Prom4s= 13dB Max risetime= 34dB/s
 Peak freqs @ 63 125 250 1250 4000
 Levels at peak freqs= 71 78 80 81 86
 Strongest freq peak @4000Hz dLpmaxLMH=-11 -5 -2 dB
 Sound indicator= engine fconthi screech
 Sound label= rpmshortacc

Vehicle data

2022-09-15 19:42:43.875 locWK Dir:East
 Moped
 PIAGGIO VESPA SPRINT 50
 Petrol 49cc 1 cyl 115 kg 1.5 kW 2 wheels
 20 km/h First reg. 05/2021
 PB level: 65dBA ST level: 78dBA
 Event#3104 Reg#99501



Figure B-4: Sound characteristics of a scooter, example of 'rpmshortacc'



This project has received funding from the European Union's Horizon Europe research and innovation programme under grant agreement No 101056777

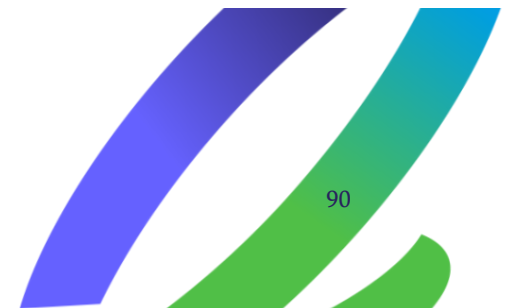

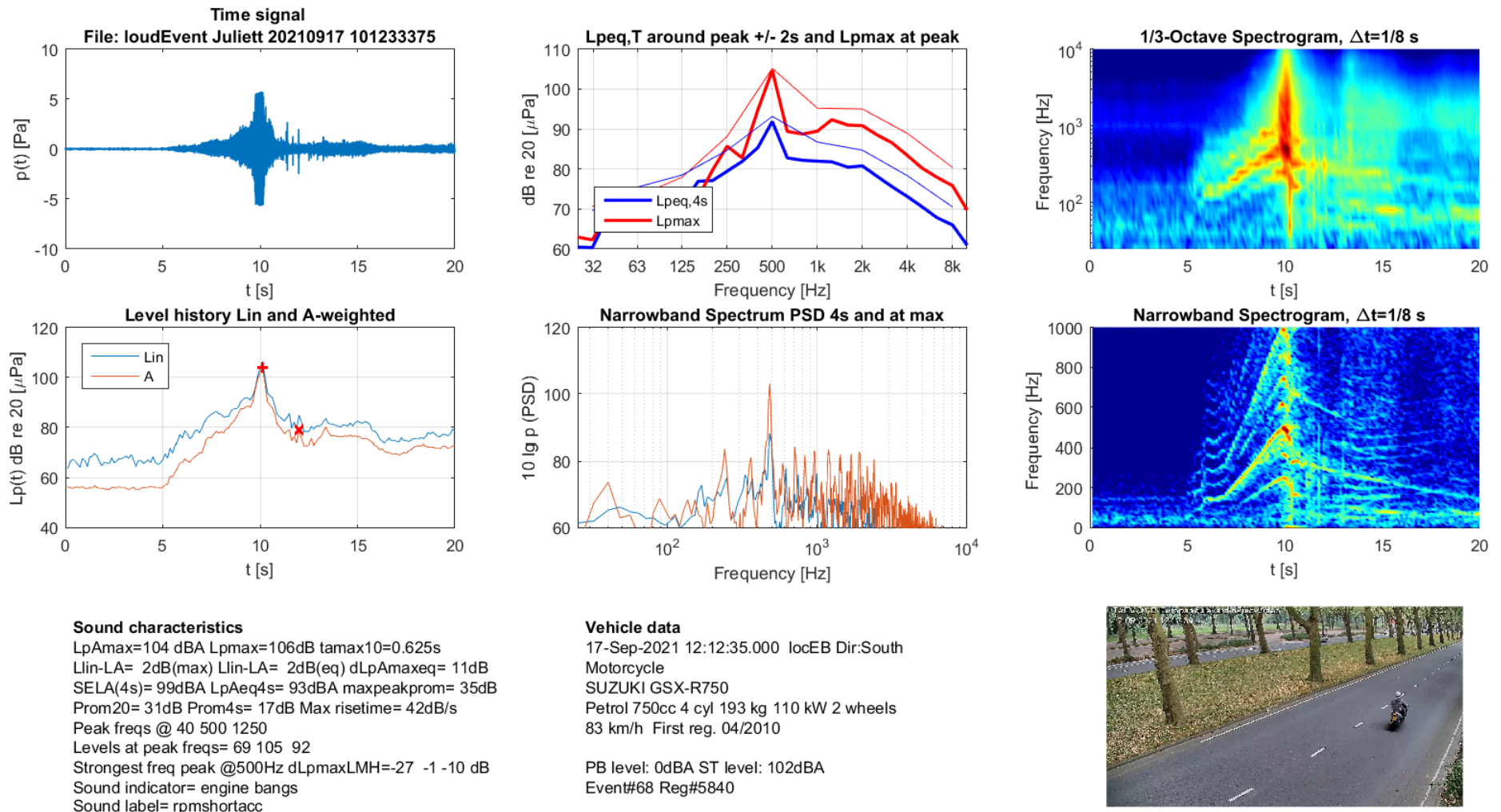

Figure B-5: Sound characteristics of a motorcycle, example of 'rpmshortacc'



This project has received funding from the European Union's Horizon Europe research and innovation programme under grant agreement No 101056777



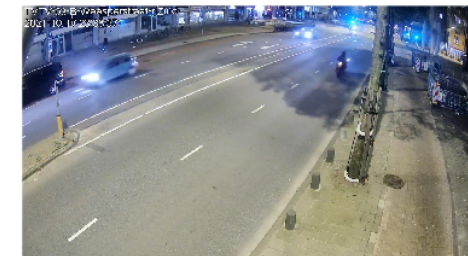
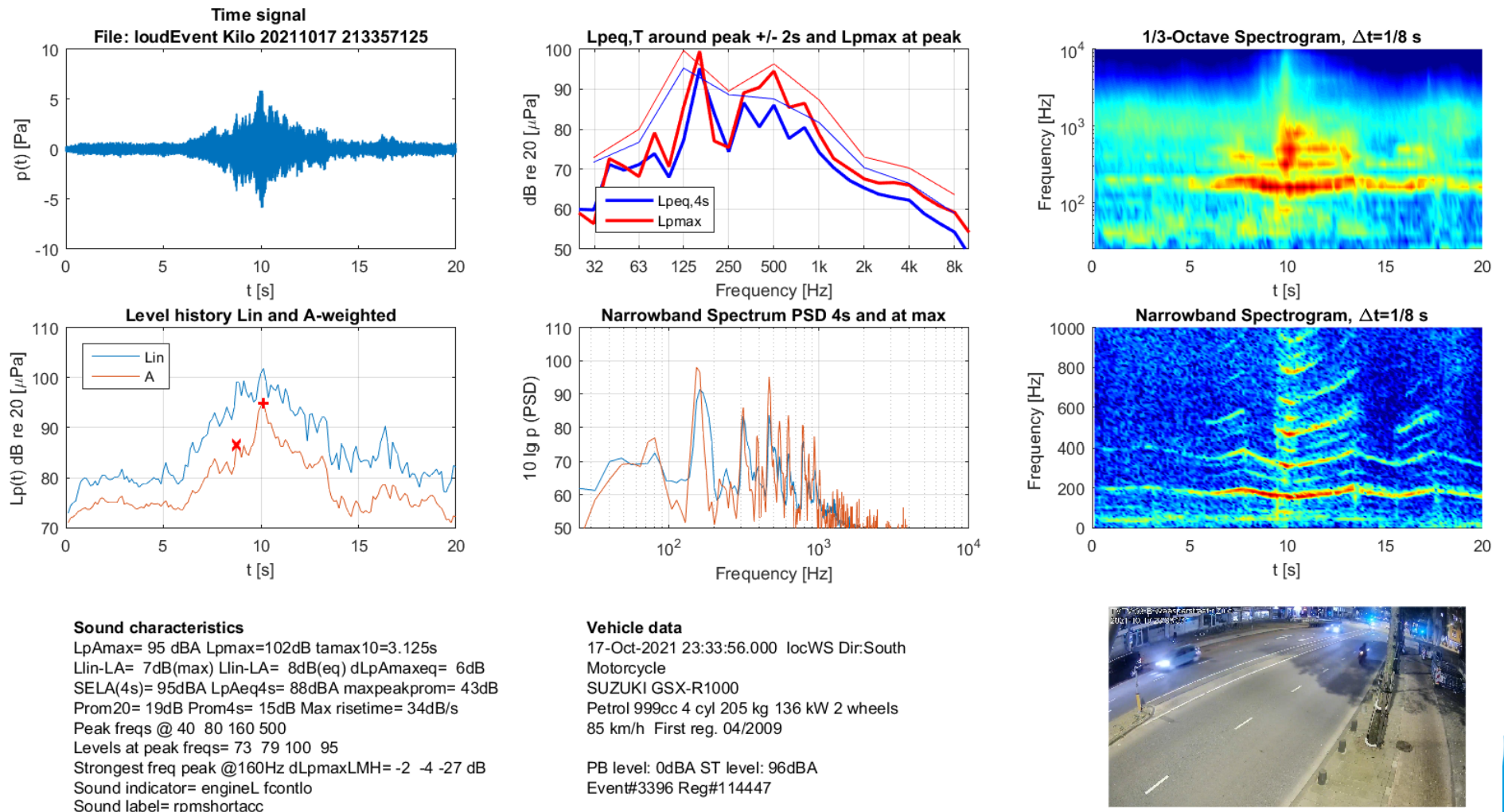

Figure B-6: Sound characteristics of a motorcycle, example of 'rpmshortacc'



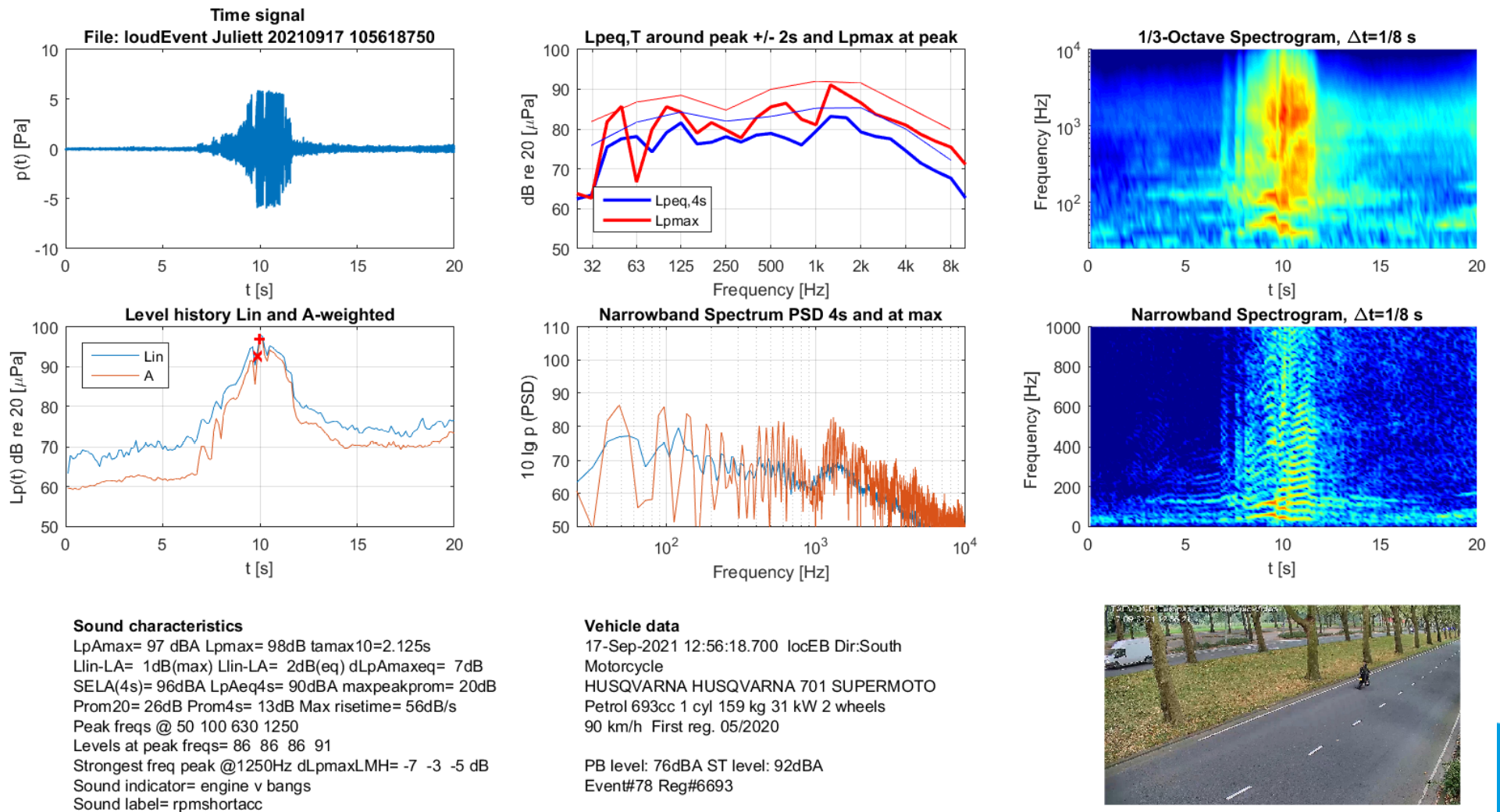
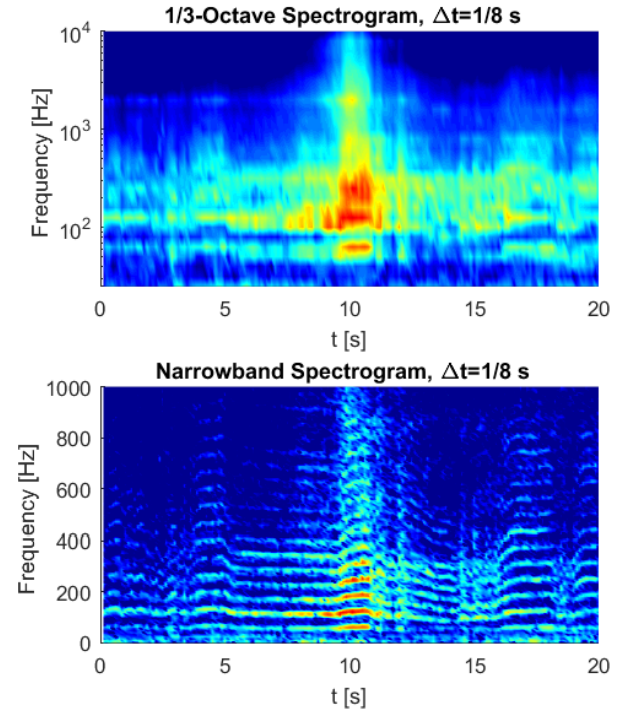
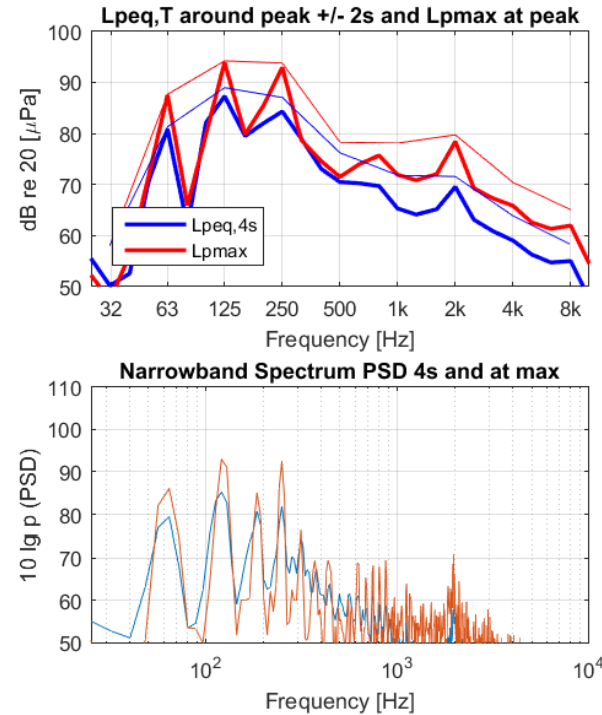
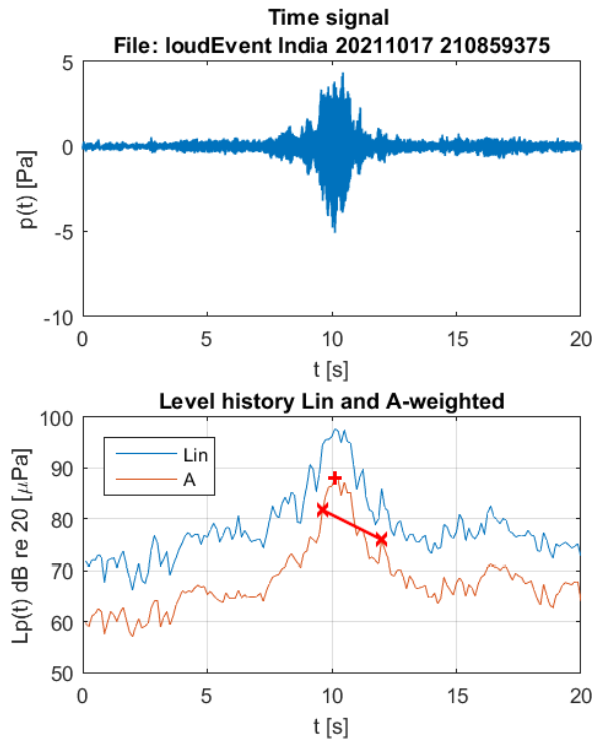

Figure B-7: Sound characteristics of a motorcycle, example of 'rpmsshortacc'



This project has received funding from the European Union's Horizon Europe research and innovation programme under grant agreement No 101056777





Sound characteristics

LpAmax= 88 dBA Lpmax= 98dB tamax10=1.5s
 Llin-LA= 10dB(max) Llin-LA= 10dB(eq) dLpAmaxeq= 6dB
 SELA(4s)= 88dBA LpAeq4s= 82dBA maxpeakprom= 39dB
 Prom20= 20dB Prom4s= 14dB Max risetime= 38dB/s
 Peak freqs @ 63 125 250 800 2000
 Levels at peak freqs= 88 94 93 76 78
 Strongest freq peak @125Hz dLpmaxLMH= -3 -4 -17 dB
 Sound indicator= engineL
 Sound label= rpmshortacc

Vehicle data

17-Oct-2021 23:08:58.000 locTM Dir:West
 Moped
 PIAGGIO ZIP
 Petrol 50cc 1 cyl 94 kg 2.3 kW 2 wheels
 51 km/h First reg. 10/2020
 PB level: 71dBA ST level: 79dBA
 Event#1262 Reg#113916



Figure B-8: Sound characteristics of a moped, example of 'rpmshortacc'



This project has received funding from the European Union's Horizon Europe research and innovation programme under grant agreement No 101056777

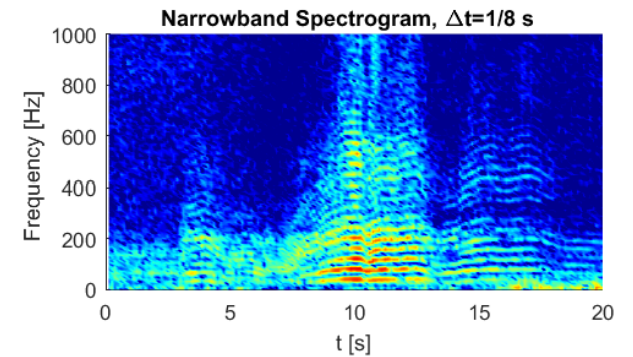
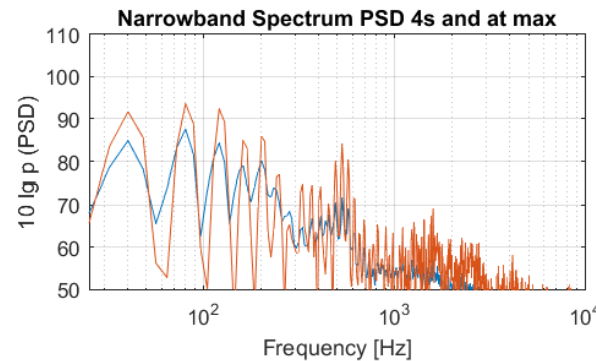
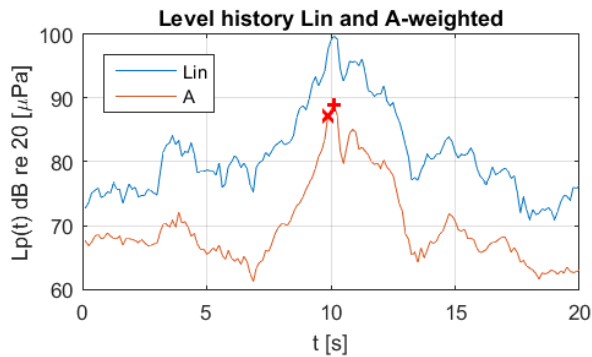
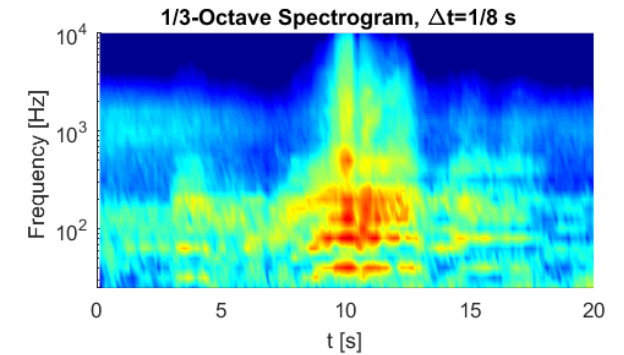
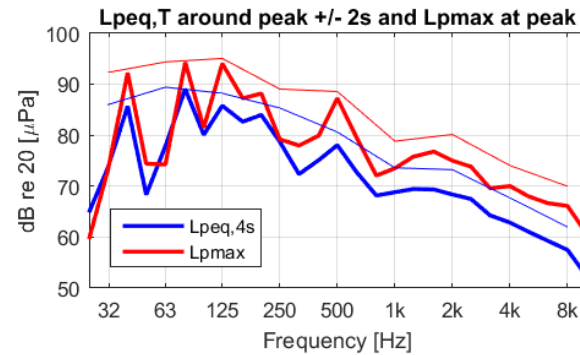
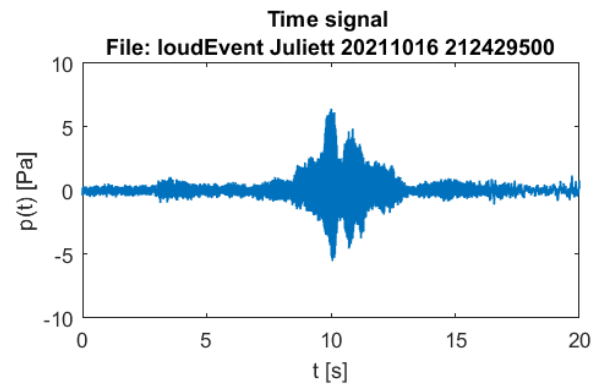

Sound characteristics

LpAmax= 89 dBA Lpmax=100dB tamax10=2.75s
 Llin-LA= 11dB(max) Llin-LA= 12dB(eq) dLpAmaxeq= 7dB
 SELA(4s)= 88dBA LpAeq4s= 82dBA maxpeakprom= 13dB
 Prom20= 20dB Prom4s= 14dB Max risetime= 30dB/s
 Peak freqs @ 40 125 500 1600
 Levels at peak freqs= 92 94 87 77
 Strongest freq peak @125Hz dLpmaxLMH= -1 -8 -18 dB
 Sound indicator= engineL fcontlo
 Sound label= rpmsshortacc

Vehicle data

16-Oct-2021 23:24:30.000 locWS Dir:North
 3W
 PIAGGIO MP3 500 LT ABS
 Petrol 493cc 1 cyl 270 kg 28.5 kW 3 wheels
 85 km/h First reg. 08/2017

 PB level: 80dBA ST level: 89dBA
 Event#2950 Reg#

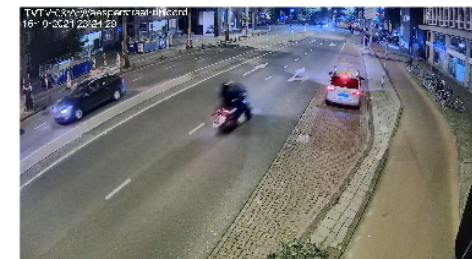

Figure B-9: Sound characteristics of a 3-wheeled scooter, example of 'rpmsshortacc'



This project has received funding from the European Union's Horizon Europe research and innovation programme under grant agreement No 101056777

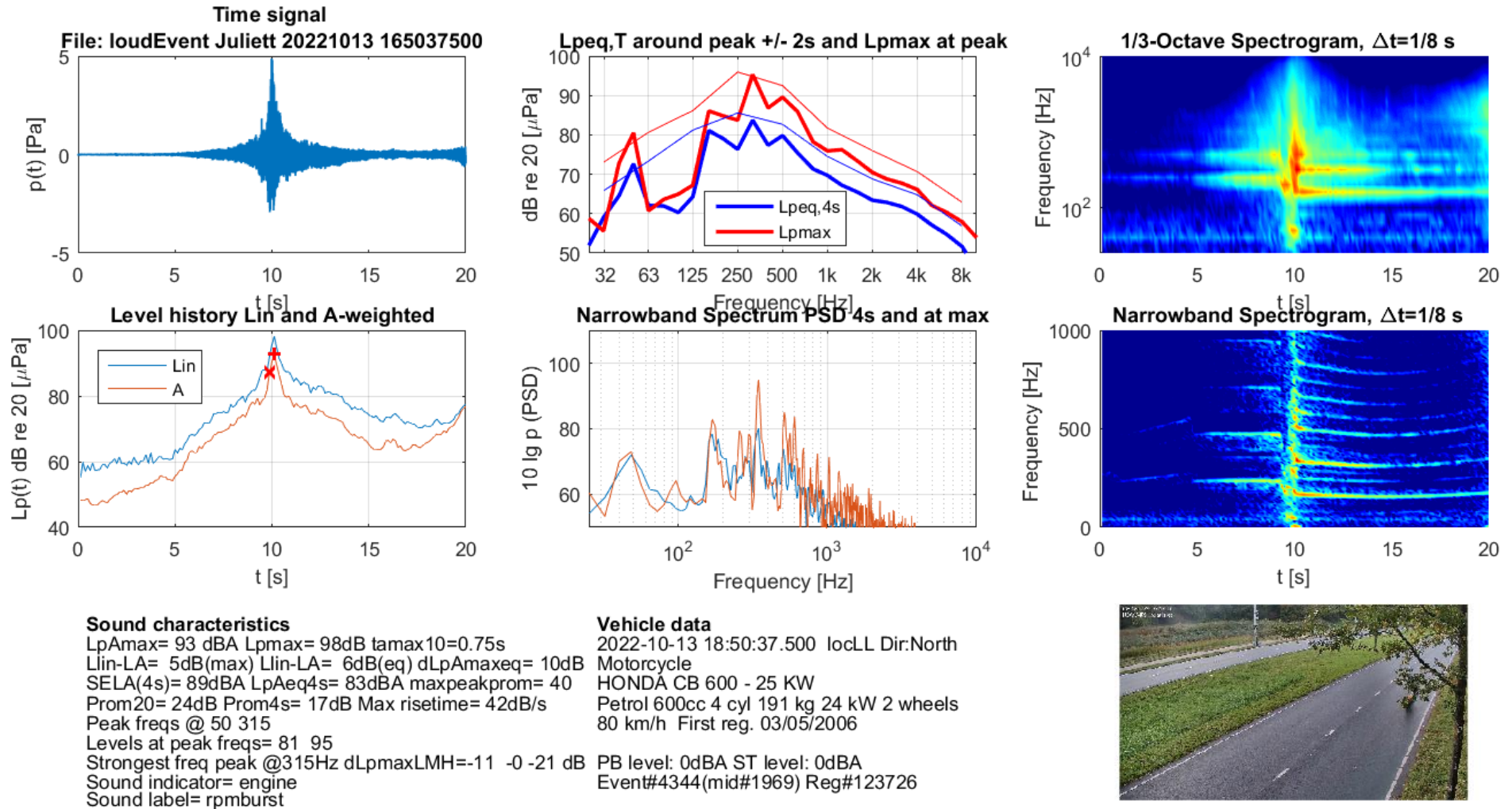

Figure B-10: Sound characteristics of a motorcycle, example of 'rpmburst' due to high speed and close range



This project has received funding from the European Union's Horizon Europe research and innovation programme under grant agreement No 101056777

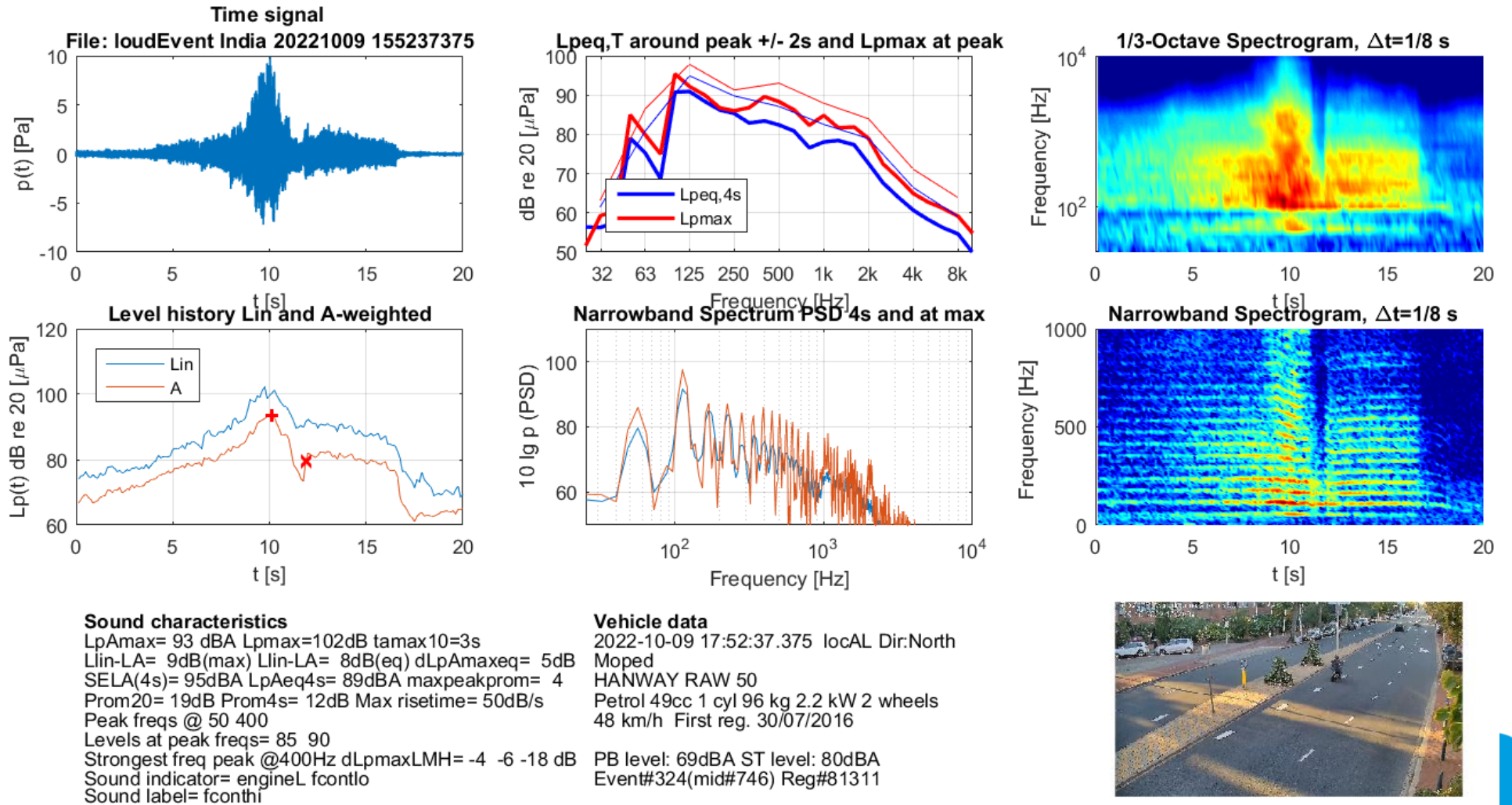

Figure B-11: Sound characteristics of a moped, example of 'fconthi/rpmconthi'



This project has received funding from the European Union's Horizon Europe research and innovation programme under grant agreement No 101056777



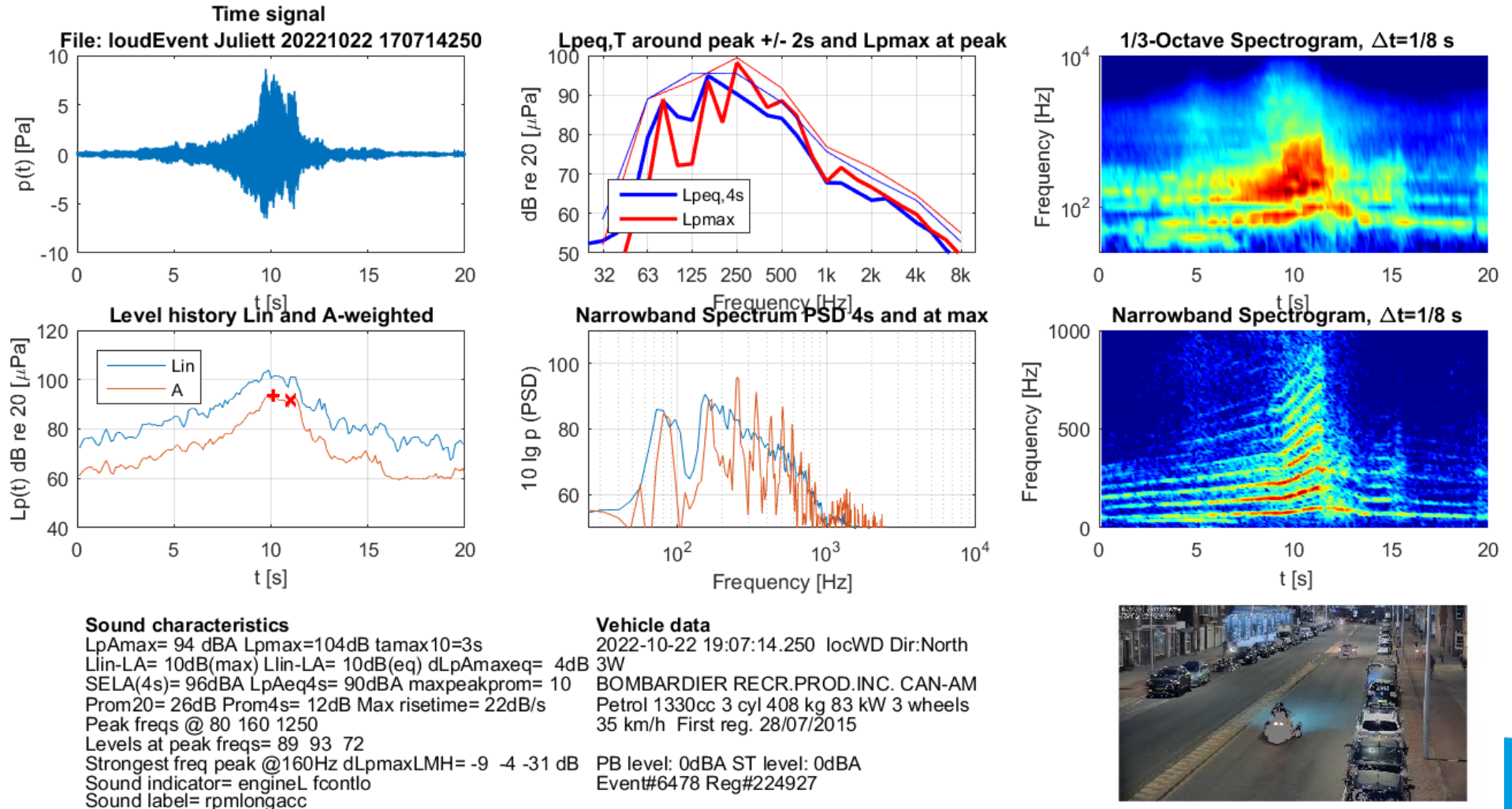

Figure B-12: Sound characteristics of a trike, example of 'rpmlongacc'



This project has received funding from the European Union's Horizon Europe research and innovation programme under grant agreement No 101056777



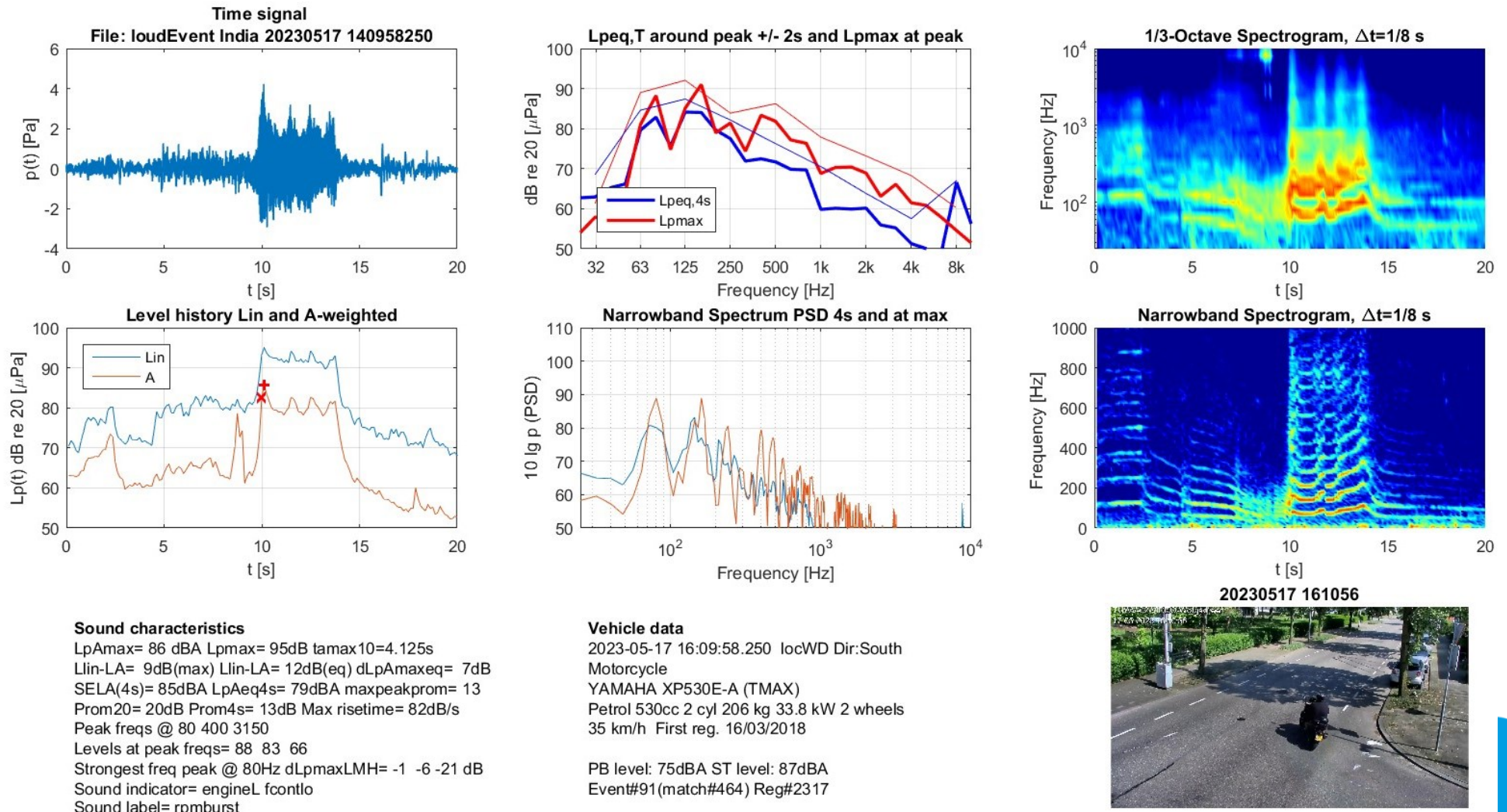
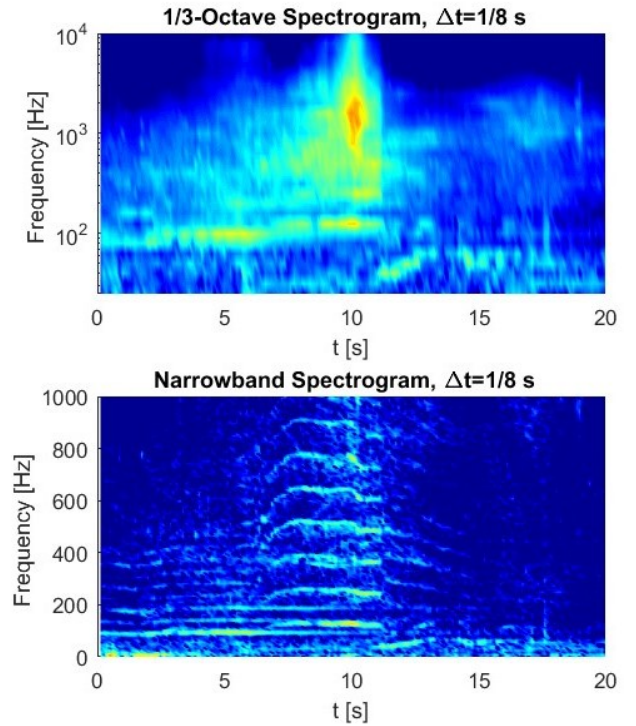
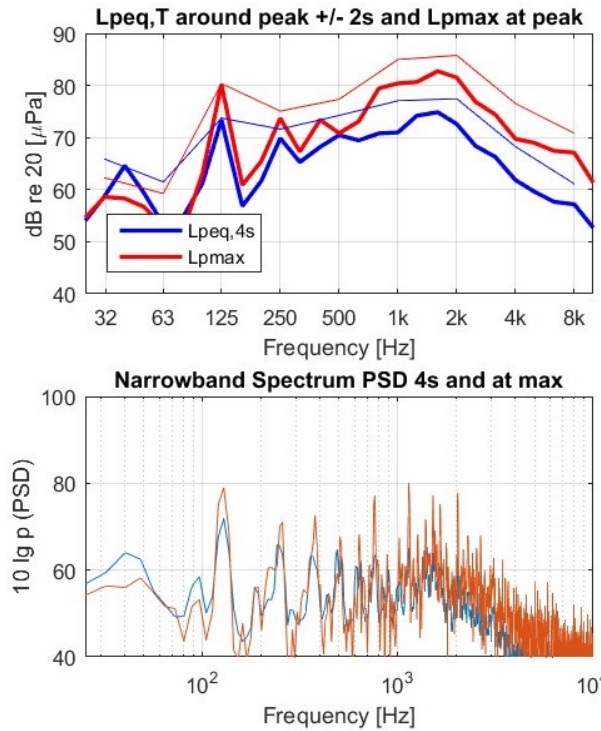
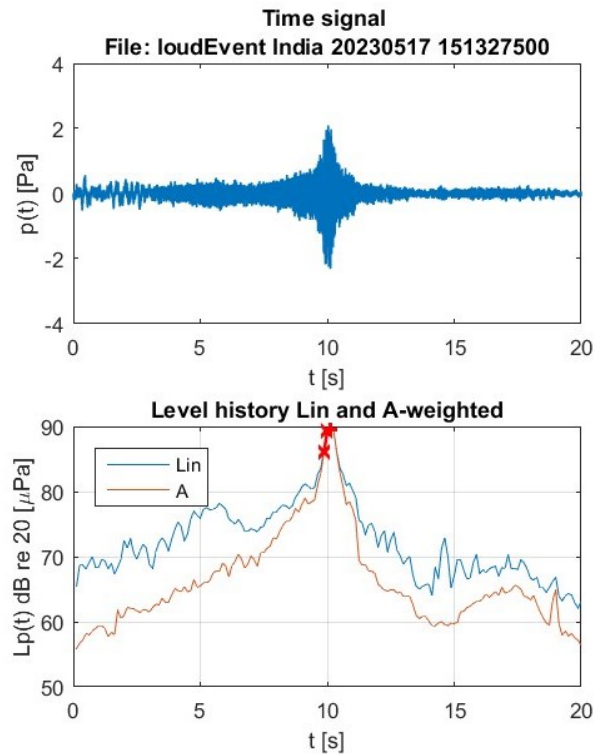

Figure B-13: Sound characteristics of a motorcycle, example of 'rpmburst'



This project has received funding from the European Union's Horizon Europe research and innovation programme under grant agreement No 101056777



Sound characteristics

LpAmax= 90 dBA Lpmax= 90dB tmax10=1.125s
 Llin-LA= 0dB(max) Llin-LA= 1dB(eq) dLpAmaxeq= 8dB
 SELA(4s)= 88dBA LpAeq4s= 82dBA maxpeakprom= 21
 Prom20= 27dB Prom4s= 16dB Max risetime= 26dB/s
 Peak freqs @ 32 125 250 1600
 Levels at peak freqs= 59 80 74 83
 Strongest freq peak @1600Hz dLpmaxLMH= -9 -4 -3 dB
 Sound indicator= engine vc bangs
 Sound label= rpmburst

Vehicle data

2023-05-17 17:13:27.500 locWD Dir:South
 Motorcycle
 GILERA M07 RUNNER
 Petrol 124cc 1 cyl 111 kg 10 kW 2 wheels
 65 km/h First reg. 16/07/1998

PB level: 77dBA ST level: 76dBA
 Event#96(match#469) Reg#2677



Figure B-14: Sound characteristics of a motorcycle, example of 'rpmburst'



This project has received funding from the European Union's Horizon Europe research and innovation programme under grant agreement No 101056777

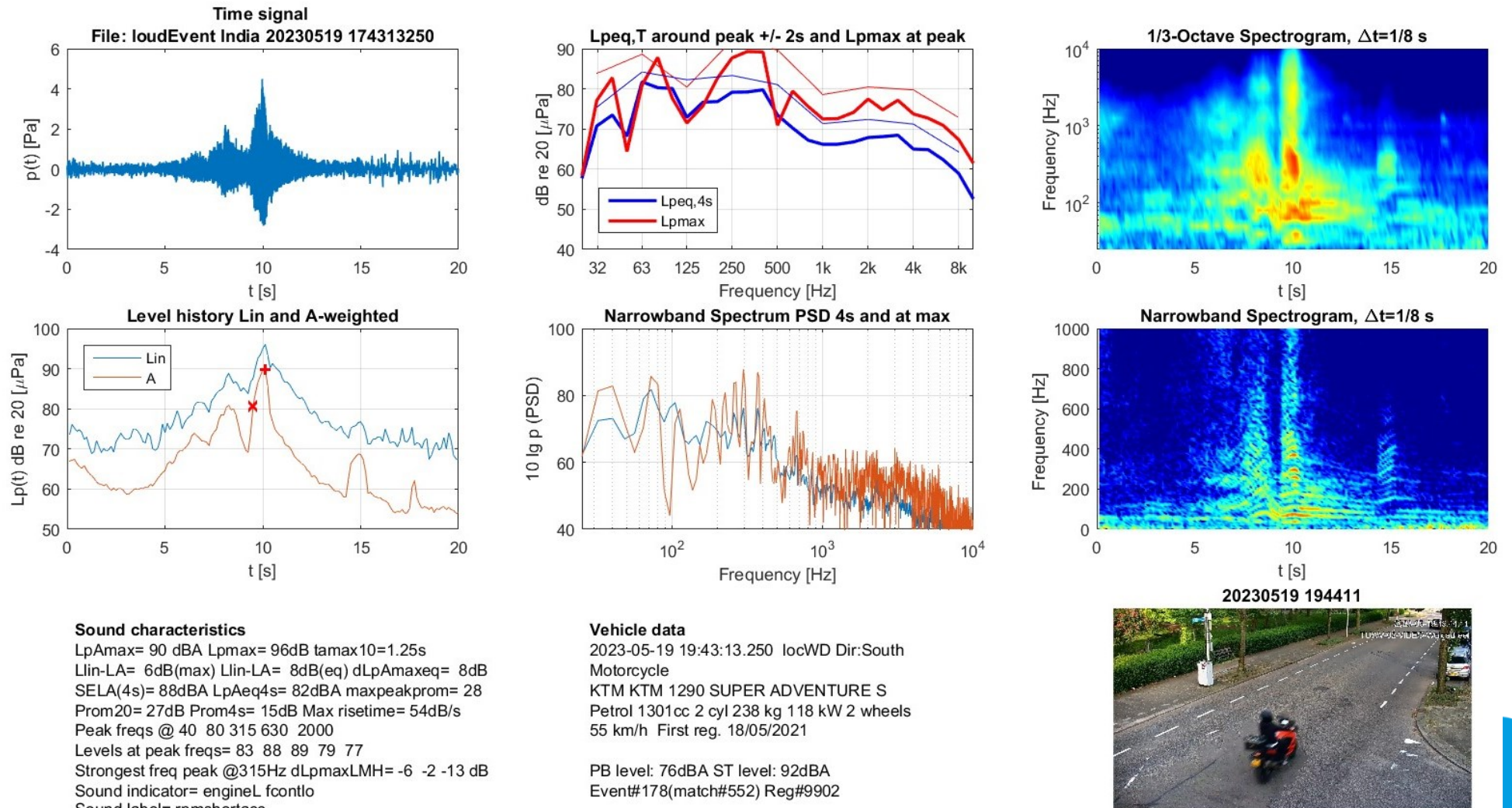

Figure B-15: Sound characteristics of a motorcycle, example of 'rpmshortacc'



This project has received funding from the European Union's Horizon Europe research and innovation programme under grant agreement No 101056777

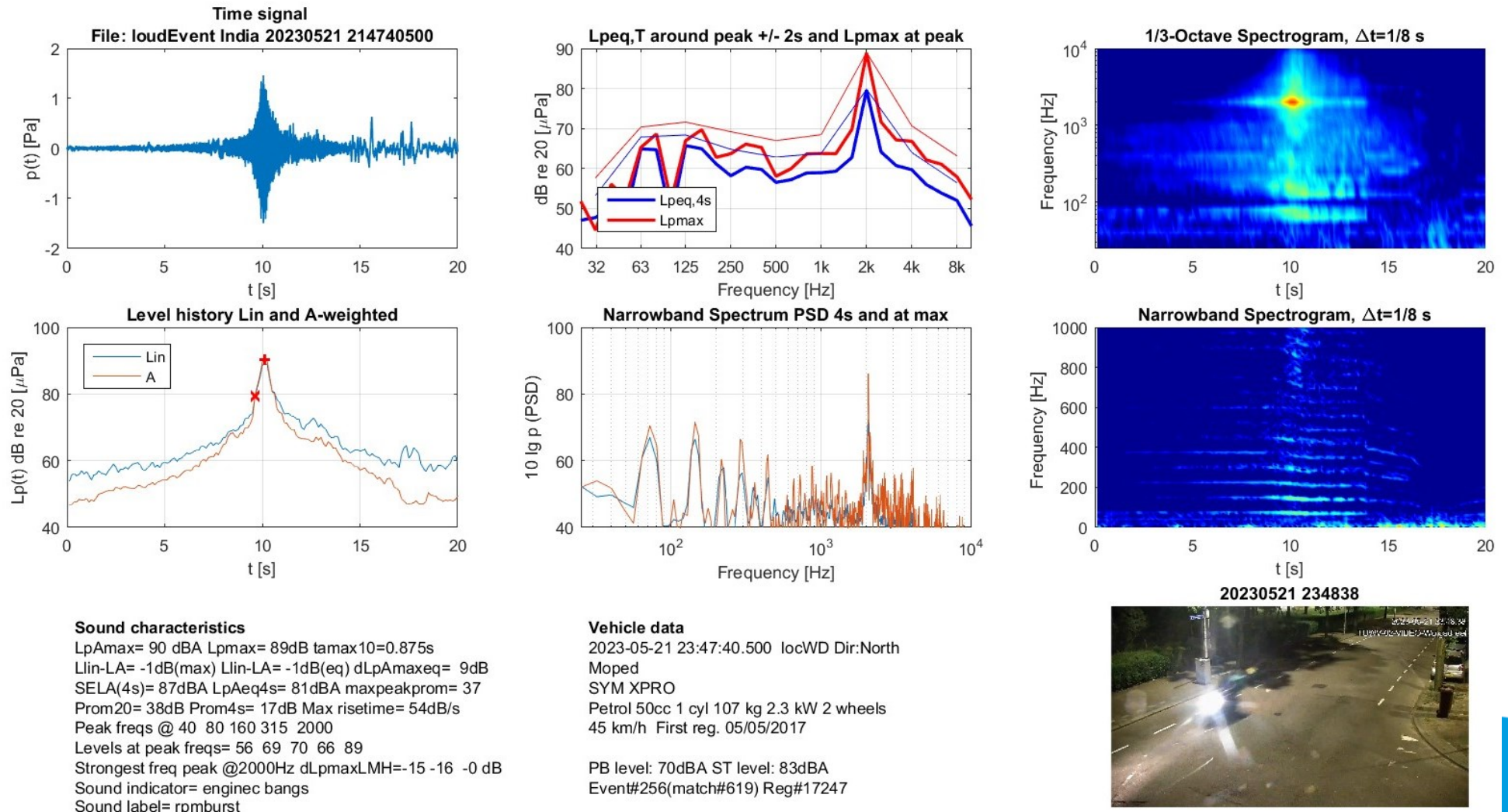
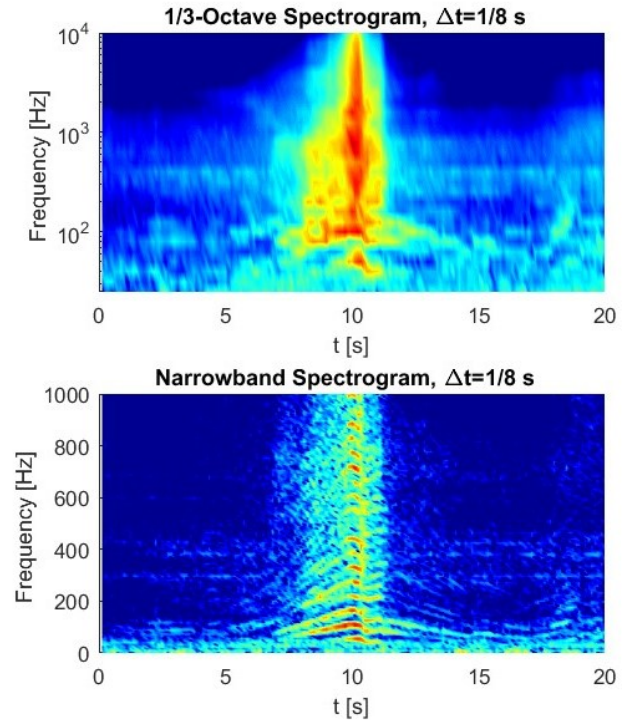
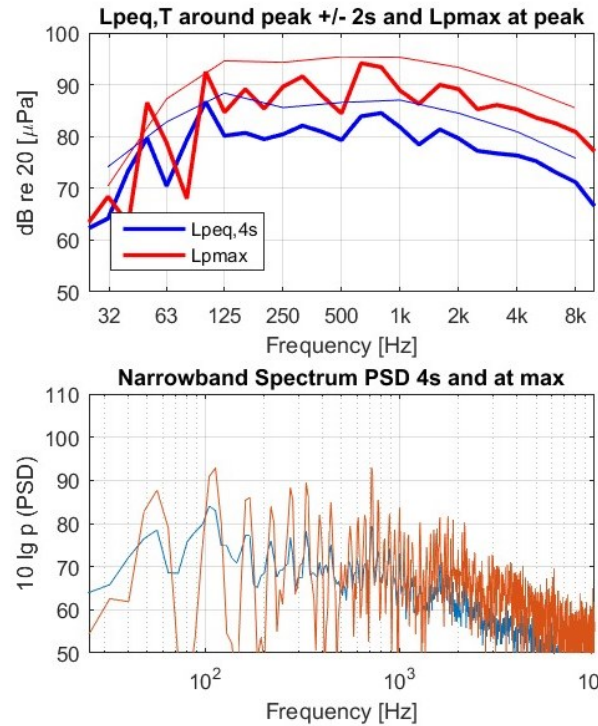
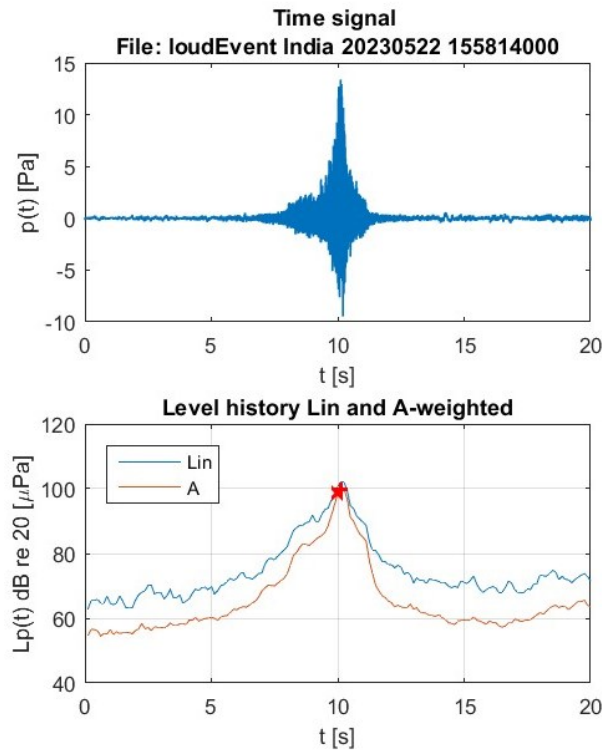

Figure B-16: Sound characteristics of a moped, example of 'rpmburst'



This project has received funding from the European Union's Horizon Europe research and innovation programme under grant agreement No 101056777



Sound characteristics

$L_{pAmax}=100$ dBA $L_{pmax}=102$ dB $t_{amax}=0.875$ s
 $L_{lin-LA}= 2$ dB(max) $L_{lin-LA}= 3$ dB(eq) $dL_{pAmaxeq}= 9$ dB
 $SELA(4s)= 97$ dBA $L_{pAeq4s}= 91$ dBA $maxpeakprom= 17$
 $Prom20= 38$ dB $Prom4s= 17$ dB $Max\ risetime= 29$ dB/s
 Peak freqs @ 32 50 100 160 315 630 1600
 Levels at peak freqs= 68 87 92 89 92 94 90
 Strongest freq peak @630Hz $dL_{pmaxLMH}= -7 -2 -7$ dB
 Sound indicator= engine
 Sound label= rpmshortacc

Vehicle data

2023-05-22 17:58:14.000 locWD Dir:South
 Motorcycle
 HONDA ADV750
 Petrol 745cc 2 cyl 229 kg 43.1 kW 2 wheels
 75 km/h First reg. 26/08/2021

 PB level: 72dBA ST level: 88dBA
 Event#281(match#639) Reg#20111



Figure B-17: Sound characteristics of a motorcycle, example of 'rpmshortacc'



This project has received funding from the European Union's Horizon Europe research and innovation programme under grant agreement No 101056777

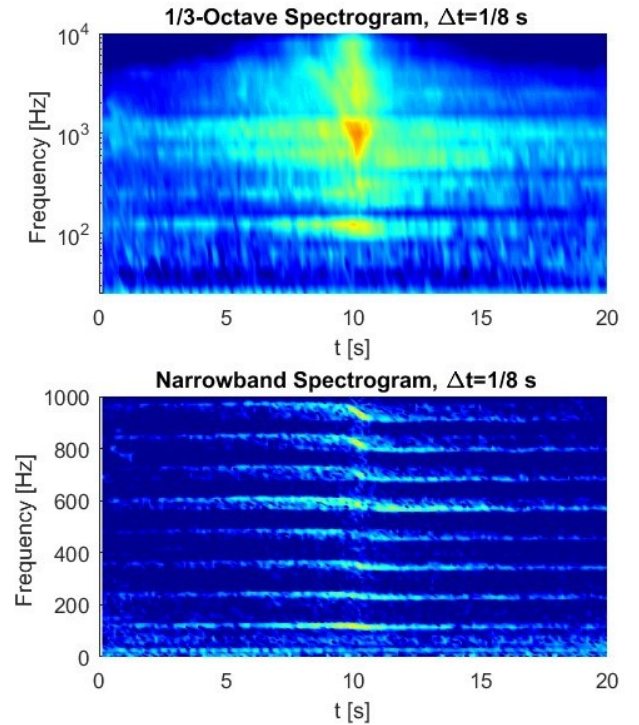
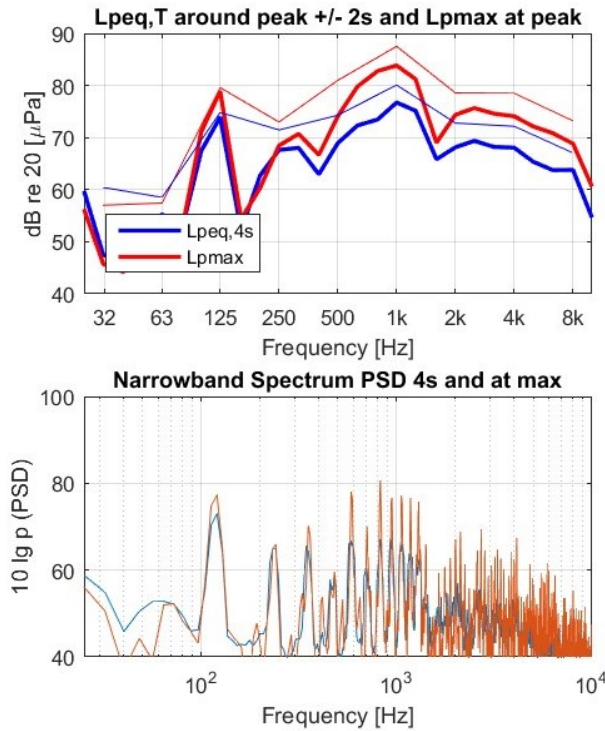
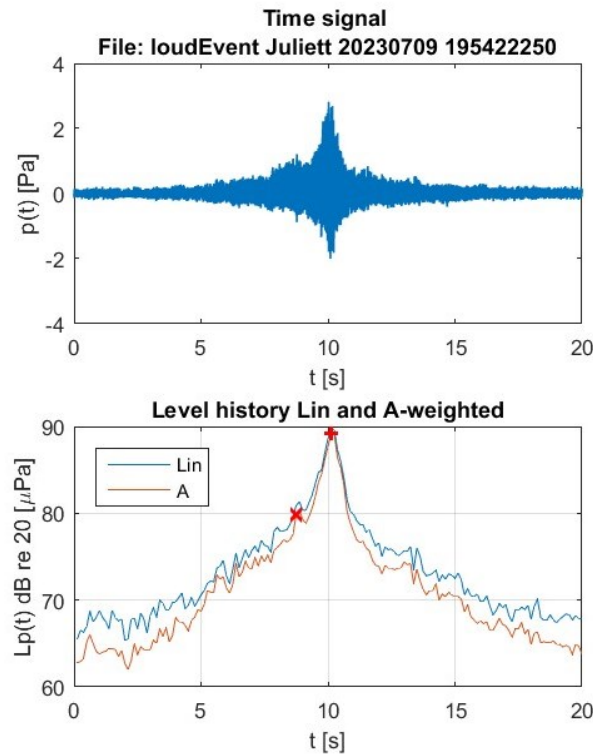

Sound characteristics

LpAmax= 89 dB Lpmax= 90dB tamax10=2s
 Llin-LA= 1dB(max) Llin-LA= 1dB(eq) dLpAmaxeq= 7dB
 SELA(4s)= 88dB LpAeq4s= 82dB maxpeakprom= 23
 Prom20= 22dB Prom4s= 15dB Max risetime= 18dB/s
 Peak freqs @125 315 1000 2500
 Levels at peak freqs= 79 71 84 76
 Strongest freq peak @1000Hz dLpmaxLMH=-10 -1 -8 dB
 Sound indicator= engine vc
 Sound label= fconthi

Vehicle data

2023-07-09 21:54:22.250 locAS Dir:North
 Moped
 PEUGEOT B1
 Petrol 49cc 1 cyl 93 kg 2.9 kW 2 wheels
 46 km/h First reg. 31/08/2005
 PB level: dBA ST level: 77dBA
 Event#2791(match#1849) Reg#103723



Figure B-18: Sound characteristics of a moped, example of 'rpmconthi'



This project has received funding from the European Union's Horizon Europe research and innovation programme under grant agreement No 101056777

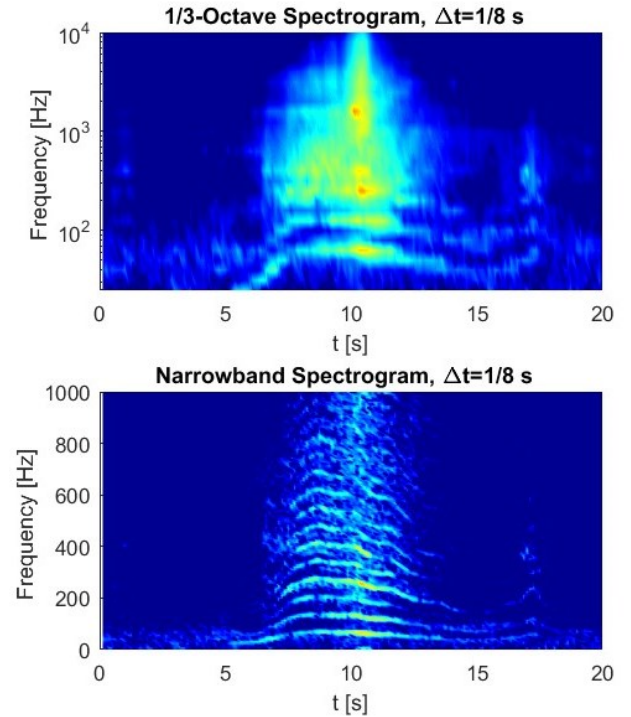
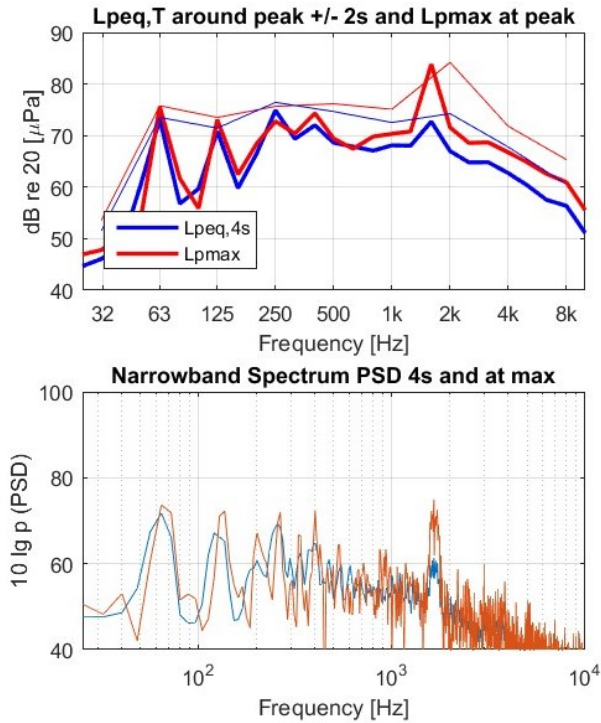
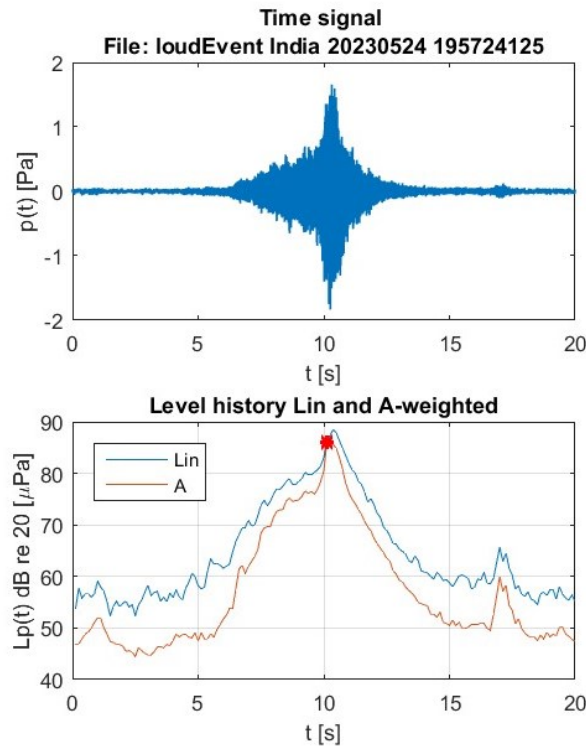

Sound characteristics

LpAmax= 86 dB Lpmax= 89dB tmax10=1.625s
 Llin-LA= 2dB(max) Llin-LA= 3dB(eq) dLpAmaxeq= 7dB
 SELA(4s)= 85dBA LpAeq4s= 79dBA maxpeakprom= 28
 Prom20= 34dB Prom4s= 14dB Max risetime= 45dB/s
 Peak freqs @ 63 125 400 1600
 Levels at peak freqs= 76 73 74 84
 Strongest freq peak @1600Hz dLpmaxLMH=-11 -8 -4 dB
 Sound indicator= engine vc bangs
 Sound label= rpmburst

Vehicle data

2023-05-24 21:57:24.125 locWD Dir:South
 Motorcycle
 PIAGGIO BEVERLY 400 HPE
 Petrol 399cc 1 cyl 188 kg 26 kW 2 wheels
 65 km/h First reg. 08/03/2022
 PB level: 76dBA ST level: 87dBA
 Event#371(match#748) Reg#29070



Figure B-19: Sound characteristics of a motorcycle, example of 'rpmburst'



This project has received funding from the European Union's Horizon Europe research and innovation programme under grant agreement No 101056777

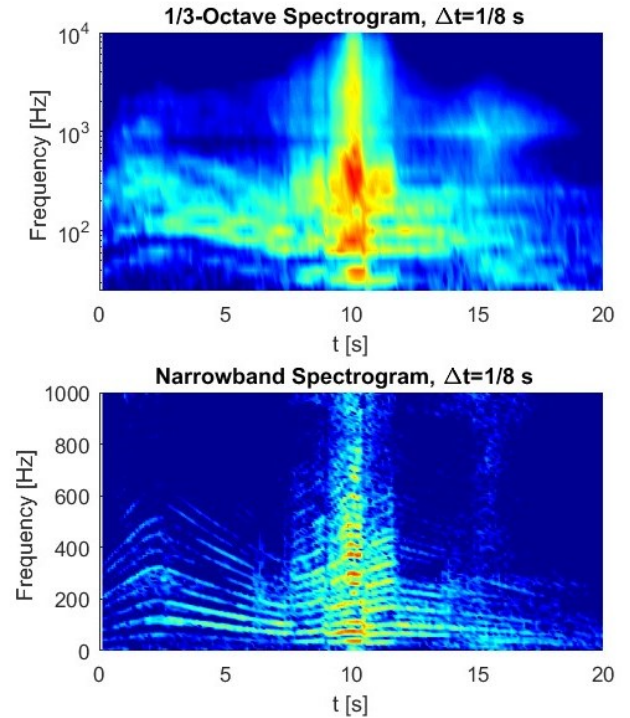
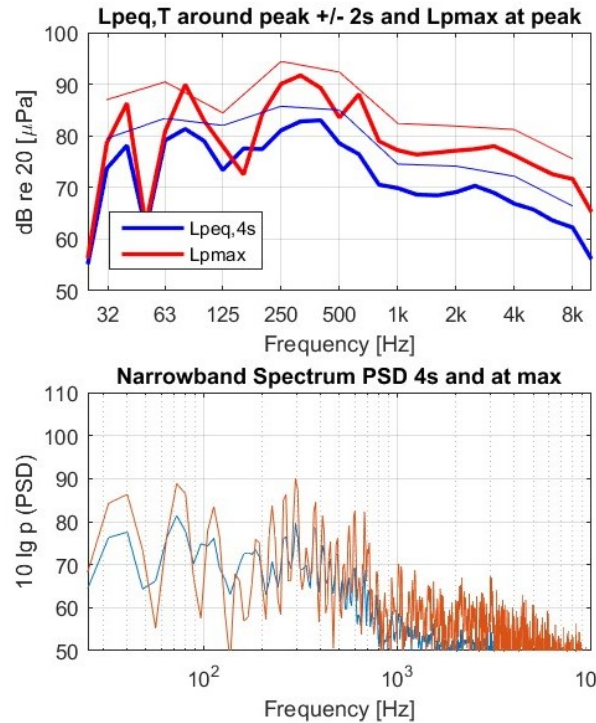
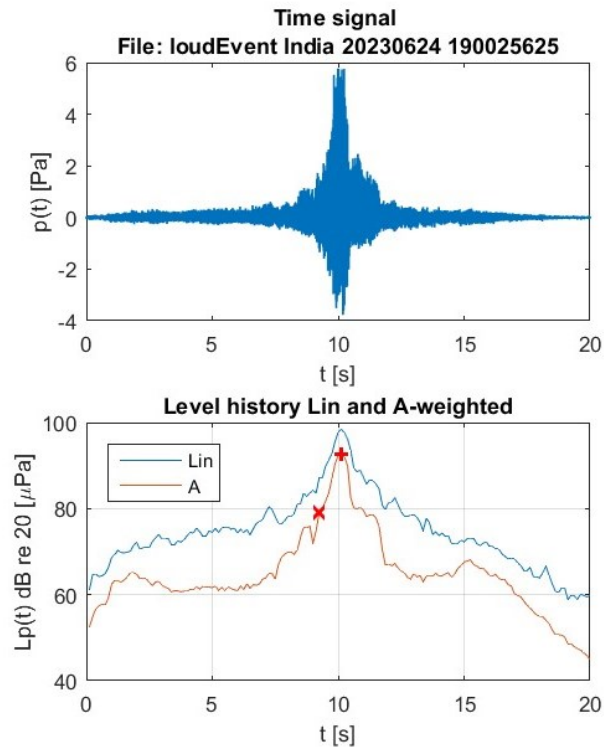

Sound characteristics

L_{pAmax} = 93 dBA L_{pmax} = 98dB t_{amax10} =0.875s
 L_{lin-LA} = 6dB(max) L_{lin-LA} = 6dB(eq) $dL_{pAmaxeq}$ = 8dB
 $SELA(4s)$ = 91dBA L_{pAeq4s} = 85dBA $maxpeakprom$ = 26
 $Prom20$ = 31dB $Prom4s$ = 16dB Max risetime= 32dB/s
 Peak freqs @ 40 80 315 630
 Levels at peak freqs= 86 90 92 88
 Strongest freq peak @315Hz $dL_{pmaxLMH}$ = -6 -2 -13 dB
 Sound indicator= engine
 Sound label= rpmburst

Vehicle data

2023-06-24 21:00:25.625 locTK Dir:South
 Motorcycle
 KTM KTM 1290 SUPER ADVENTURE S
 Petrol 1301cc 2 cyl 238 kg 118 kW 2 wheels
 91 km/h First reg. 18/05/2021

 PB level: 76dBA ST level: 92dBA
 Event#878(match#1220) Reg#42410



Figure B-20: Sound characteristics of a motorcycle, example of 'rpmburst'



This project has received funding from the European Union's Horizon Europe research and innovation programme under grant agreement No 101056777

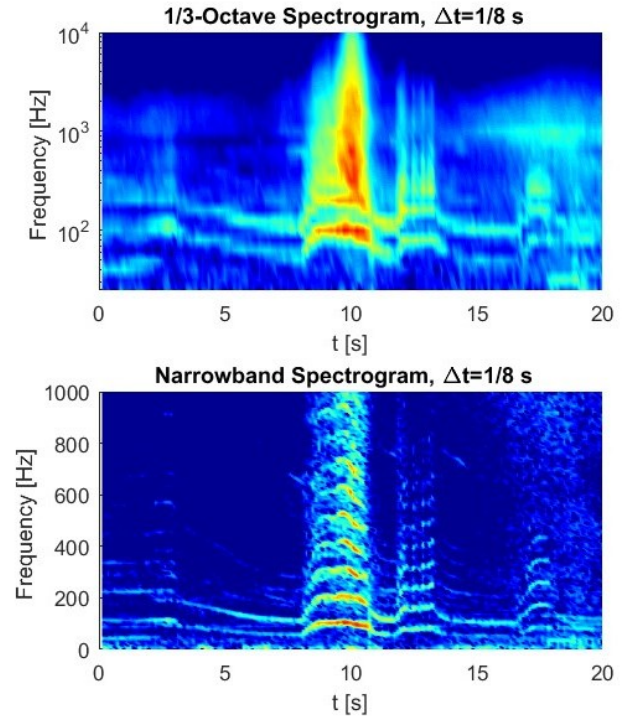
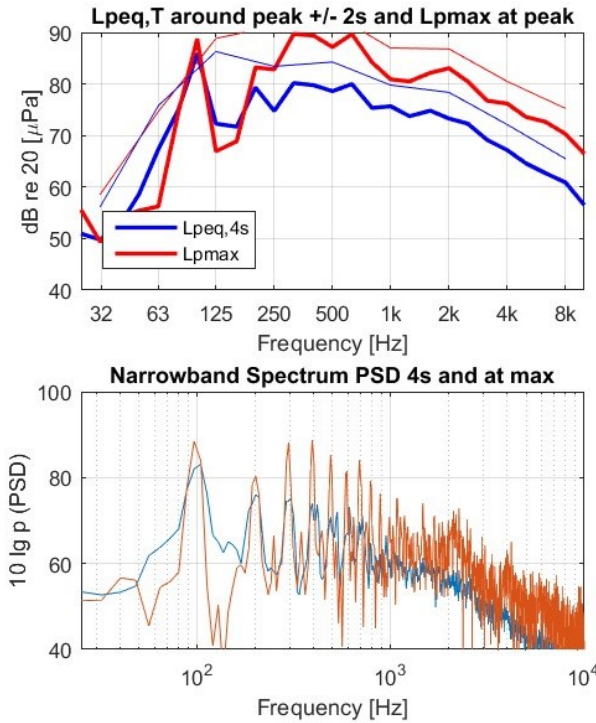
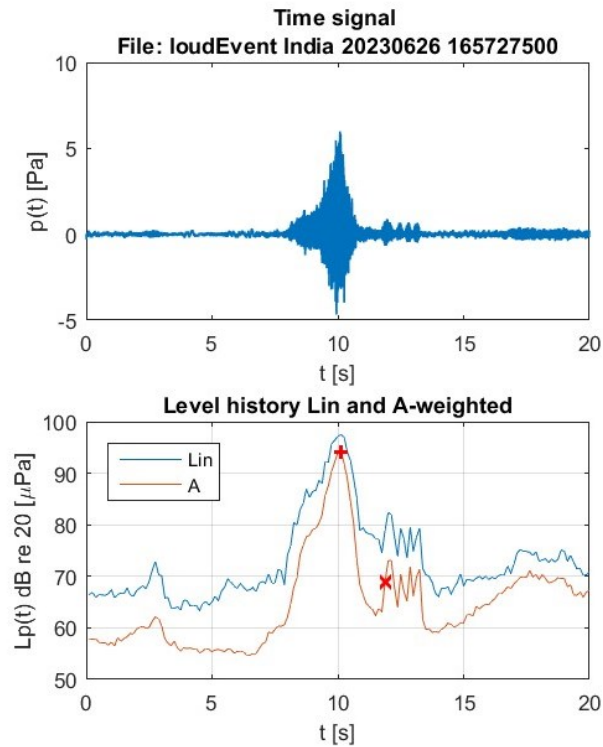

Sound characteristics

LpAmax= 94 dBA Lpmax= 98dB tmax10=1.125s
 Llin-LA= 3dB(max) Llin-LA= 5dB(eq) dLpAmaxeq= 8dB
 SELA(4s)= 92dBA LpAeq4s= 86dBA maxpeakprom= 22
 Prom20= 26dB Prom4s= 15dB Max risetime= 46dB/s
 Peak freqs @100
 Levels at peak freqs= 89
 Strongest freq peak @100Hz dLpmaxLMH= -9 -1 -10 dB
 Sound indicator= engine
 Sound label= rpmshortacc

Vehicle data

2023-06-26 18:57:27.500 locTK Dir:South
 Motorcycle
 YAMAHA XP500A
 Petrol 530cc 2 cyl 210 kg 34.2 kW 2 wheels
 89 km/h First reg. 01/03/2016
 PB level: 77dBA ST level: 86dBA
 Event#953(match#1273) Reg#51430



Figure B-21: Sound characteristics of a motorcycle, example of 'rpmshortacc'



This project has received funding from the European Union's Horizon Europe research and innovation programme under grant agreement No 101056777

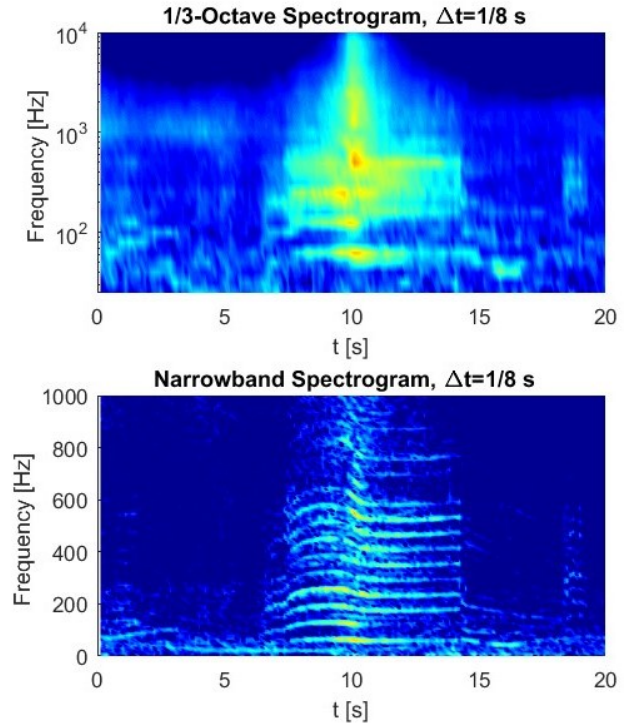
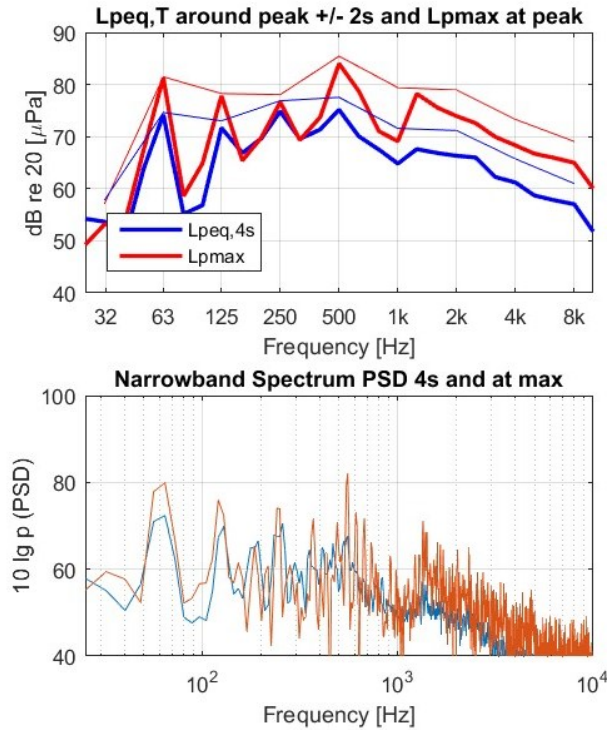
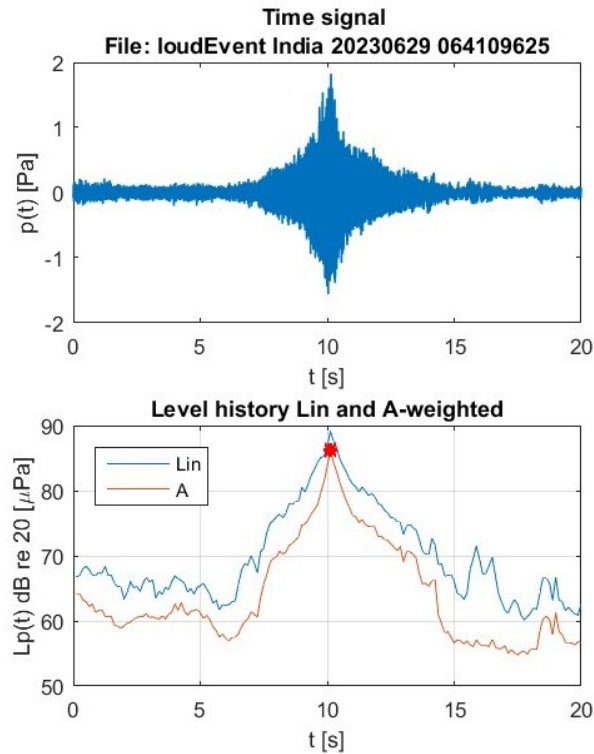

Sound characteristics

LpAmax= 86 dBA Lpmax= 89dB t_{max10}=1.625s
 L_{lin}-L_A= 3dB(max) L_{lin}-L_A= 4dB(eq) dLpAmaxeq= 8dB
 SELA(4s)= 85dBA LpAeq4s= 79dBA maxpeakprom= 24
 Prom20= 25dB Prom4s= 15dB Max risetime= 20dB/s
 Peak freqs @ 63 125 250 500 1250
 Levels at peak freqs= 81 78 77 84 78
 Strongest freq peak @500Hz dLpmaxLMH= -6 -2 -9 dB
 Sound indicator= engine v bangs
 Sound label= rpmburst

Vehicle data

2023-06-29 08:41:09.625 locTK Dir:South
 3W
 PIAGGIO N/A
 Petrol 278cc 1 cyl 217 kg 17 kW 3 wheels
 69 km/h First reg. 07/10/2011

PB level: dBA ST level: dBA
 Event#1037(match#1335) Reg#64797



Figure B-22: Sound characteristics of a trike, example of 'rpmburst'



This project has received funding from the European Union's Horizon Europe research and innovation programme under grant agreement No 101056777

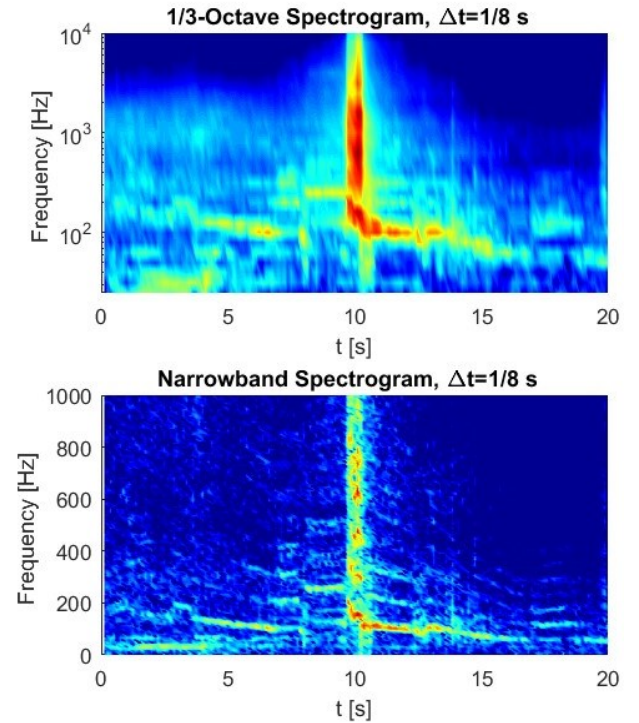
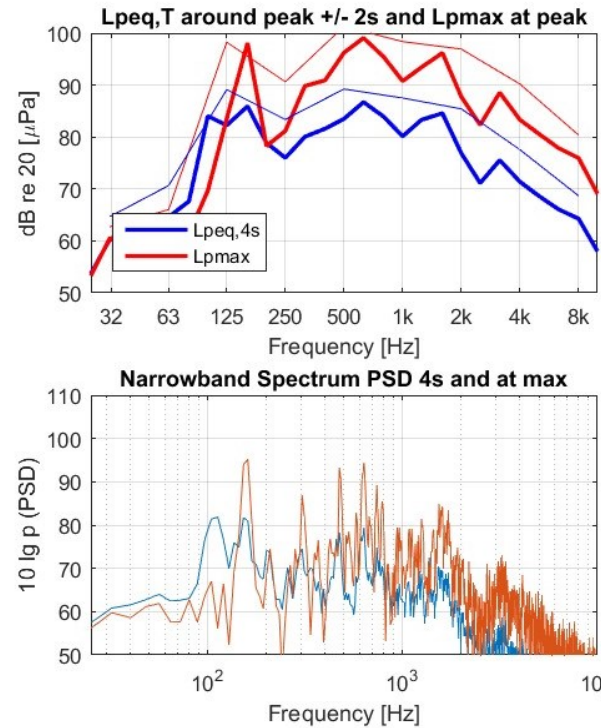
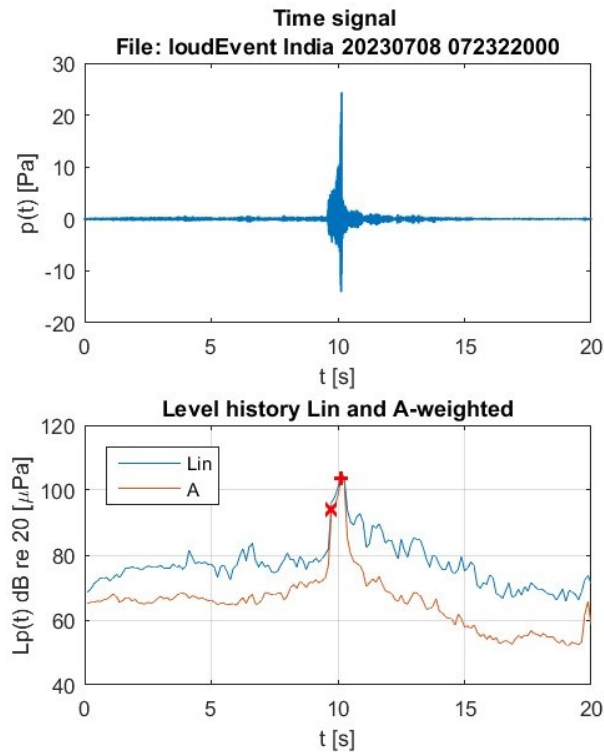

Sound characteristics

LpAmax=104 dBA Lpmax=105dB tamax10=0.625s
 Llin-LA= 2dB(max) Llin-LA= 3dB(eq) dLpAmaxeq= 11dB
 SELA(4s)= 98dBA LpAeq4s= 92dBA maxpeakprom= 30
 Prom20= 37dB Prom4s= 19dB Max risetime=136dB/s
 Peak freqs @ 32 160 630 1600 3150
 Levels at peak freqs= 61 98 99 96 89
 Strongest freq peak @630Hz dLpmaxLMH= -7 -2 -8 dB
 Sound indicator= engine
 Sound label= rpmburst

Vehicle data

2023-07-08 09:23:22.000 locAS Dir:South
 Motorcycle
 YAMAHA MTN850-A (MT-09 ABS)
 Petrol 847cc 3 cyl 186 kg 84.6 kW 2 wheels
 86 km/h First reg. 06/03/2017

PB level: 75dBA ST level: 93dBA
 Event#1657(match#2610) Reg#85627

20230708 092419



Figure B-23: Sound characteristics of a motorcycle, example of 'rpmburst'



This project has received funding from the European Union's Horizon Europe research and innovation programme under grant agreement No 101056777

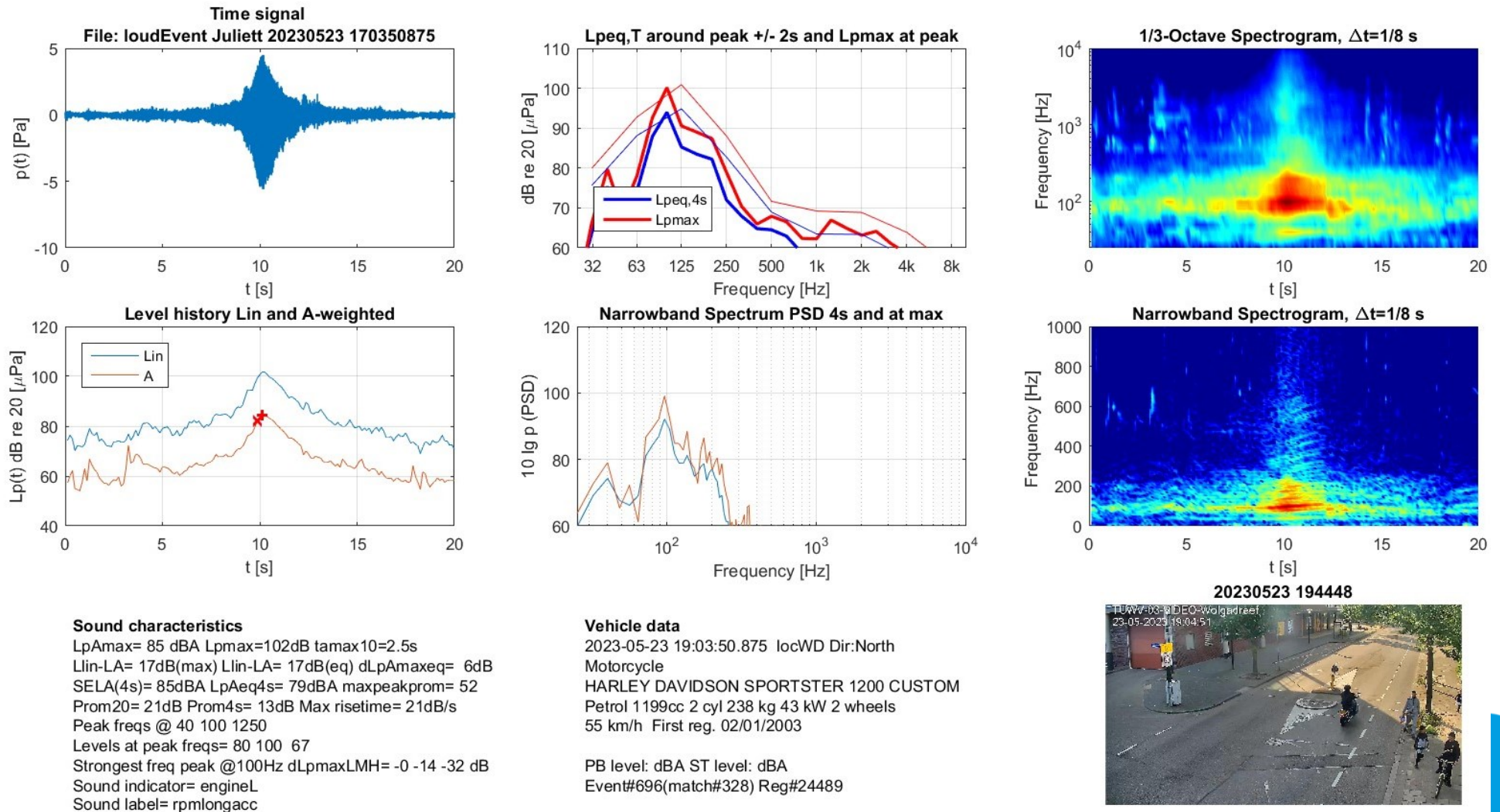
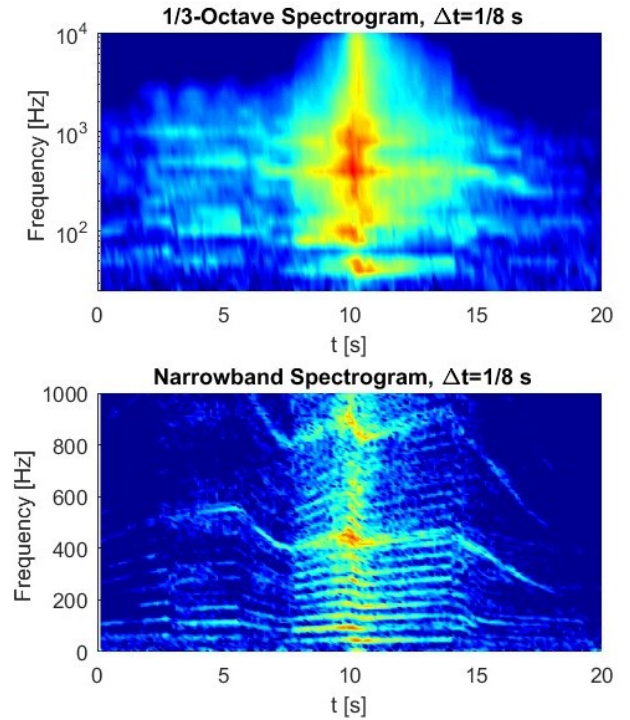
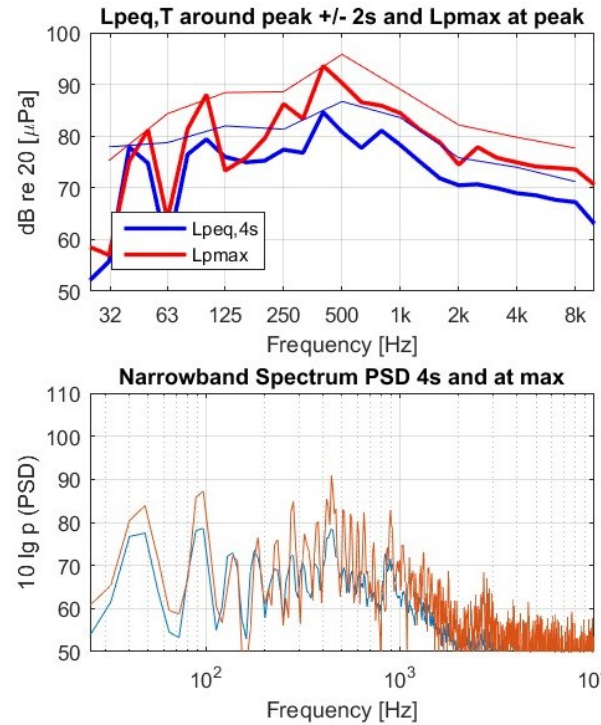
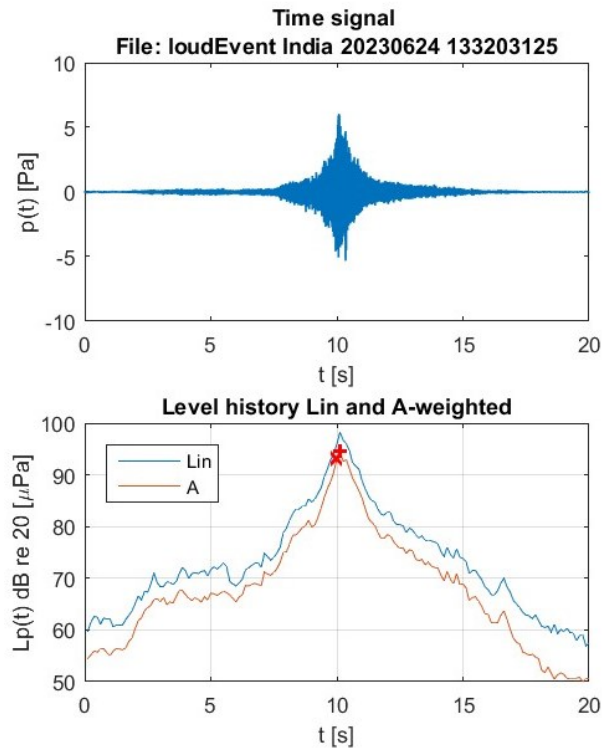

Figure B-24: Sound characteristics of a motorcycle, example of 'rpmlongacc'



This project has received funding from the European Union's Horizon Europe research and innovation programme under grant agreement No 101056777



Sound characteristics

L_{pAmax} = 95 dBA L_{pmax} = 98dB t_{amax} =1.625s
 L_{lin-LA} = 4dB(max) L_{lin-LA} = 4dB(eq) $dL_{pAmaxeq}$ = 7dB
 $SELA(4s)$ = 93dBA L_{pAeq4s} = 87dBA $max_{peakprom}$ = 23
 $Prom_{20}$ = 31dB $Prom_{4s}$ = 15dB $Max_{risetime}$ = 21dB/s
 Peak freqs @ 50 100 400 2500
 Levels at peak freqs= 81 88 94 78
 Strongest freq peak @400Hz $dL_{pmaxLMH}$ = -8 -1 -13 dB
 Sound indicator= engine
 Sound label= rpmburst

Vehicle data

2023-06-24 15:32:03.125 locTK Dir:South
 3W
 YAMAHA YFM 660 R
 Petrol cc 1 cyl 200 kg kW 4 wheels
 92 km/h First reg. 15/02/2003

 PB level: dBA ST level: dBA
 Event#870(match#1206) Reg#40881



Figure B-25: Sound characteristics of a quad, example of 'rpmburst'



This project has received funding from the European Union's Horizon Europe research and innovation programme under grant agreement No 101056777

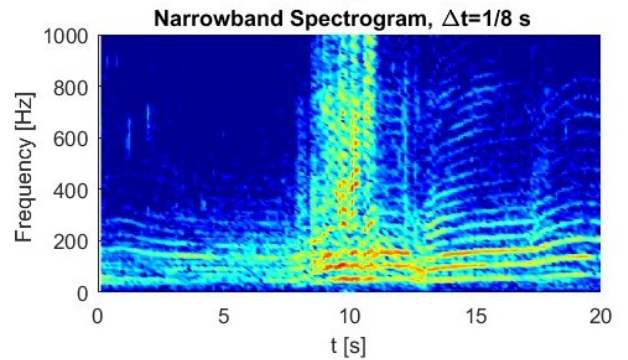
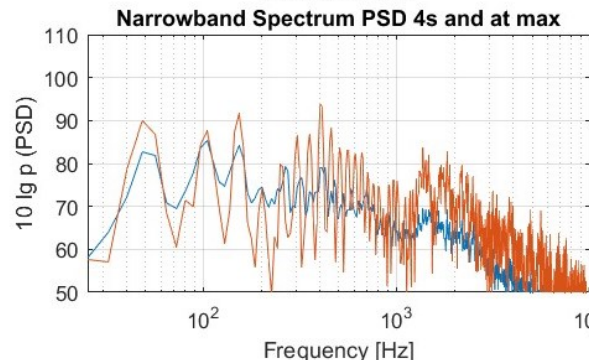
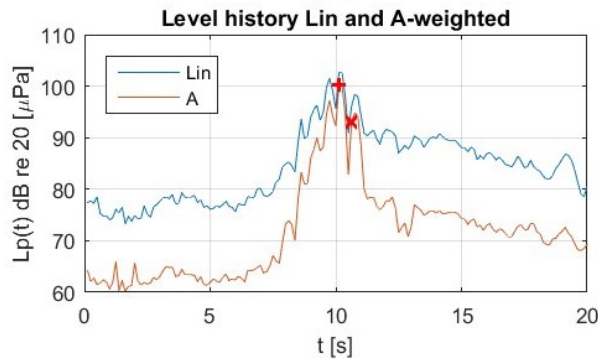
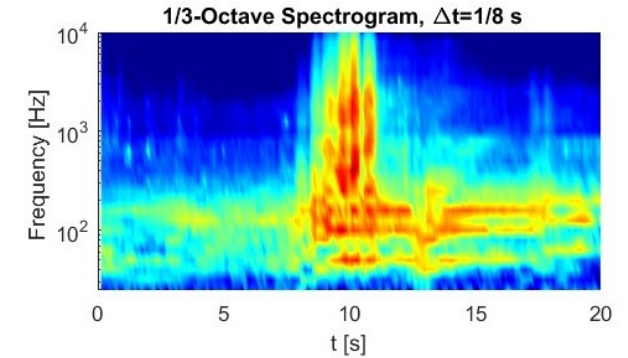
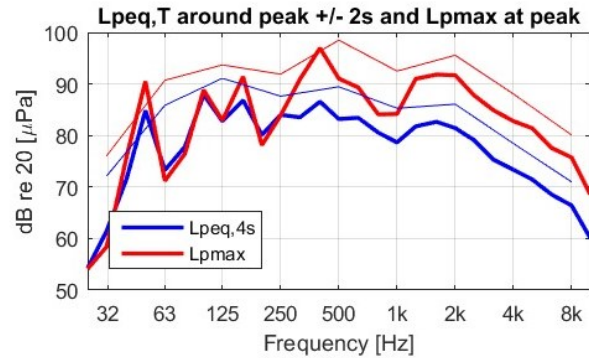
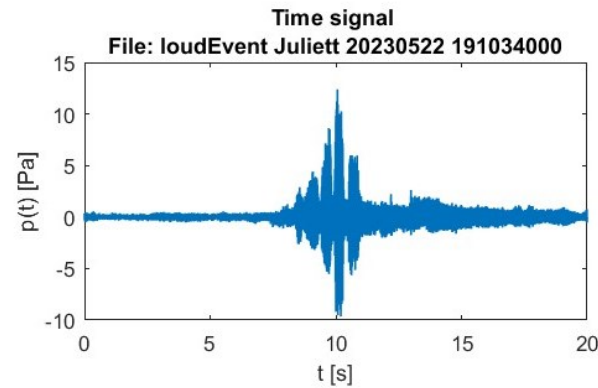

Sound characteristics

LpAmax=100 dBA Lpmax=103dB tamax10=1.25s
 Llin-LA= 2dB(max) Llin-LA= 4dB(eq) dLpAmaxeq= 9dB
 SELA(4s)= 98dBA LpAeq4s= 92dBA maxpeakprom= 8
 Prom20= 28dB Prom4s= 16dB Max risetime= 82dB/s
 Peak freqs @ 50 100 160 1600
 Levels at peak freqs= 90 89 91 92
 Strongest freq peak @1600Hz dLpmaxLMH= -7 -2 -6 dB
 Sound indicator= engine v bangs
 Sound label= rpmburst

Vehicle data

2023-05-22 21:10:34.000 locWD Dir:North
 Motorcycle
 GILERA M55
 Petrol 839cc 2 cyl 238 kg 51 kW 2 wheels
 65 km/h First reg. 17/07/2008

PB level: dBA ST level: 93dBA
 Event#657(match#295) Reg#20828



Figure B-26: Sound characteristics of a motorcycle, example of 'rpmburst'



This project has received funding from the European Union's Horizon Europe research and innovation programme under grant agreement No 101056777

B2 Examples of spectrograms of loud events at 3 positions

In the following examples from the three Utrecht locations, narrowband spectrograms are shown of loud pass-bys measured at 3 positions simultaneously. The first and second positions with vehicle type indicated are those with ANPR cameras fitted. The third position ('Fox') is further along the road than the other two ('Ind' and 'Jul') as show in Figure 2-27. In some cases differences between the spectral characteristics at the three microphone positions can be seen.

Table B1 Geometry of the Utrecht measurement sites, as indicated in Figure 2-27. The microphone height is 4 m in all cases.

Location	a (m)	e (m)	f (m)	b (m)	g (m)
WD	12	55	57	10	8.5
TK	28	16	36	10	8
AS	65	15	24	8.5	7

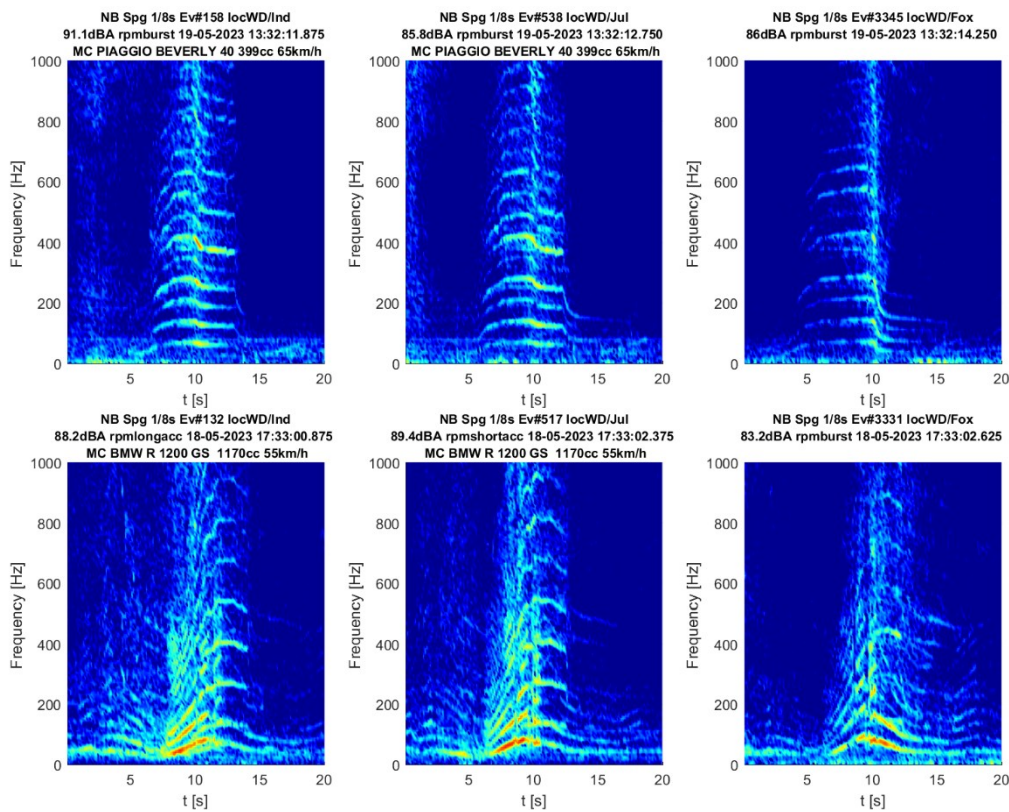

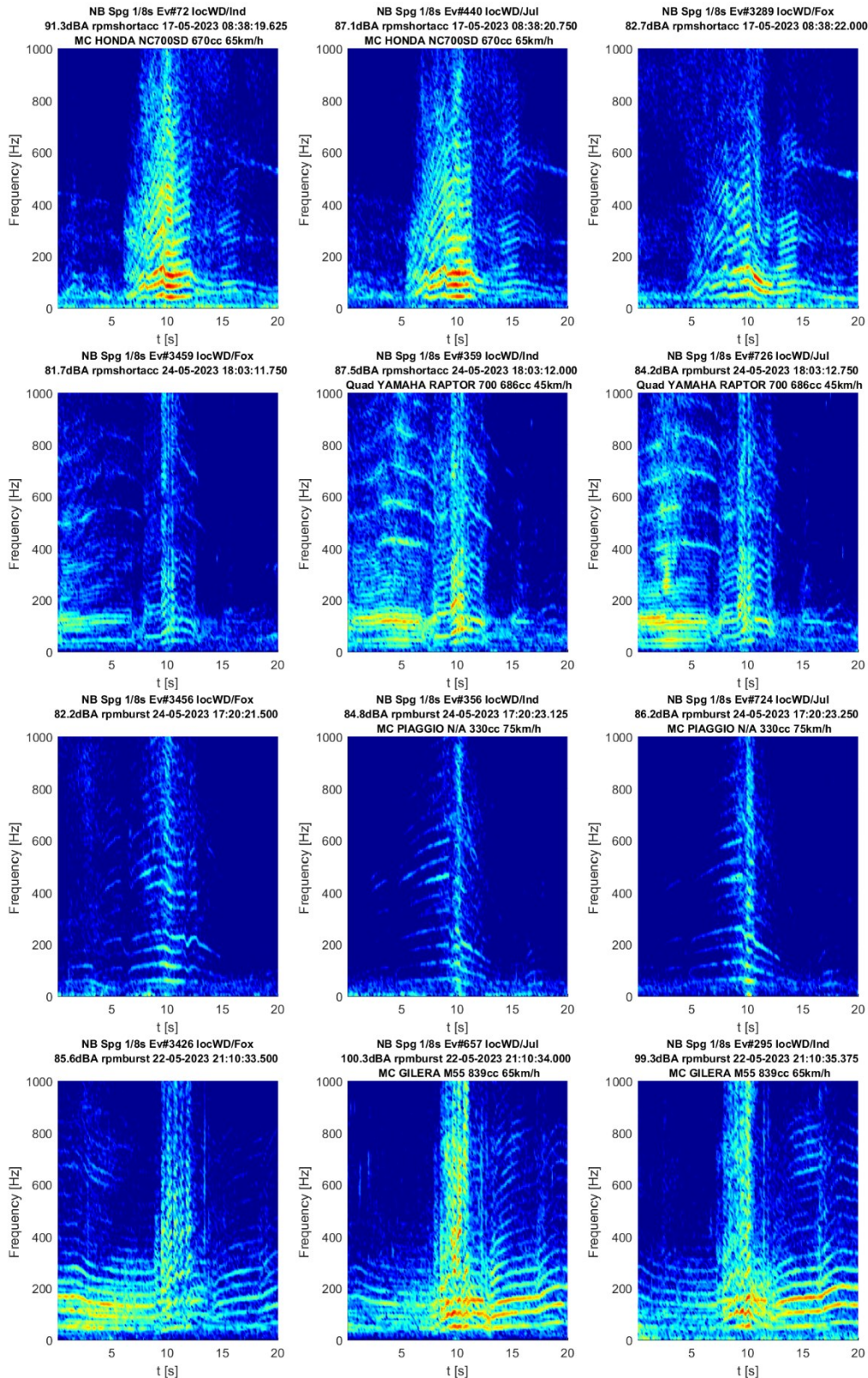

This project has received funding from the European Union's Horizon Europe research and innovation programme under grant agreement No 101056777

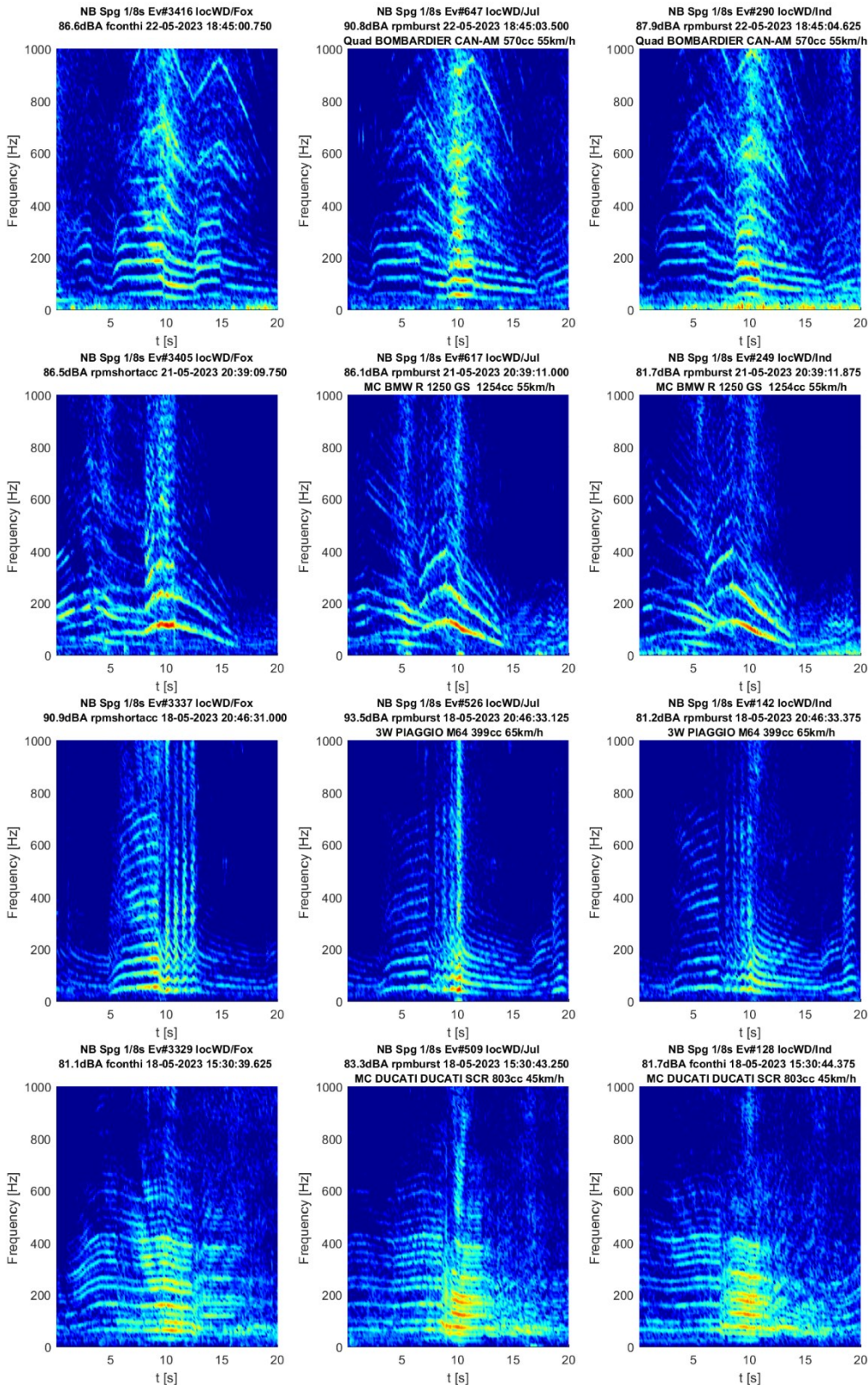

This project has received funding from the European Union's Horizon Europe research and innovation programme under grant agreement No 101056777

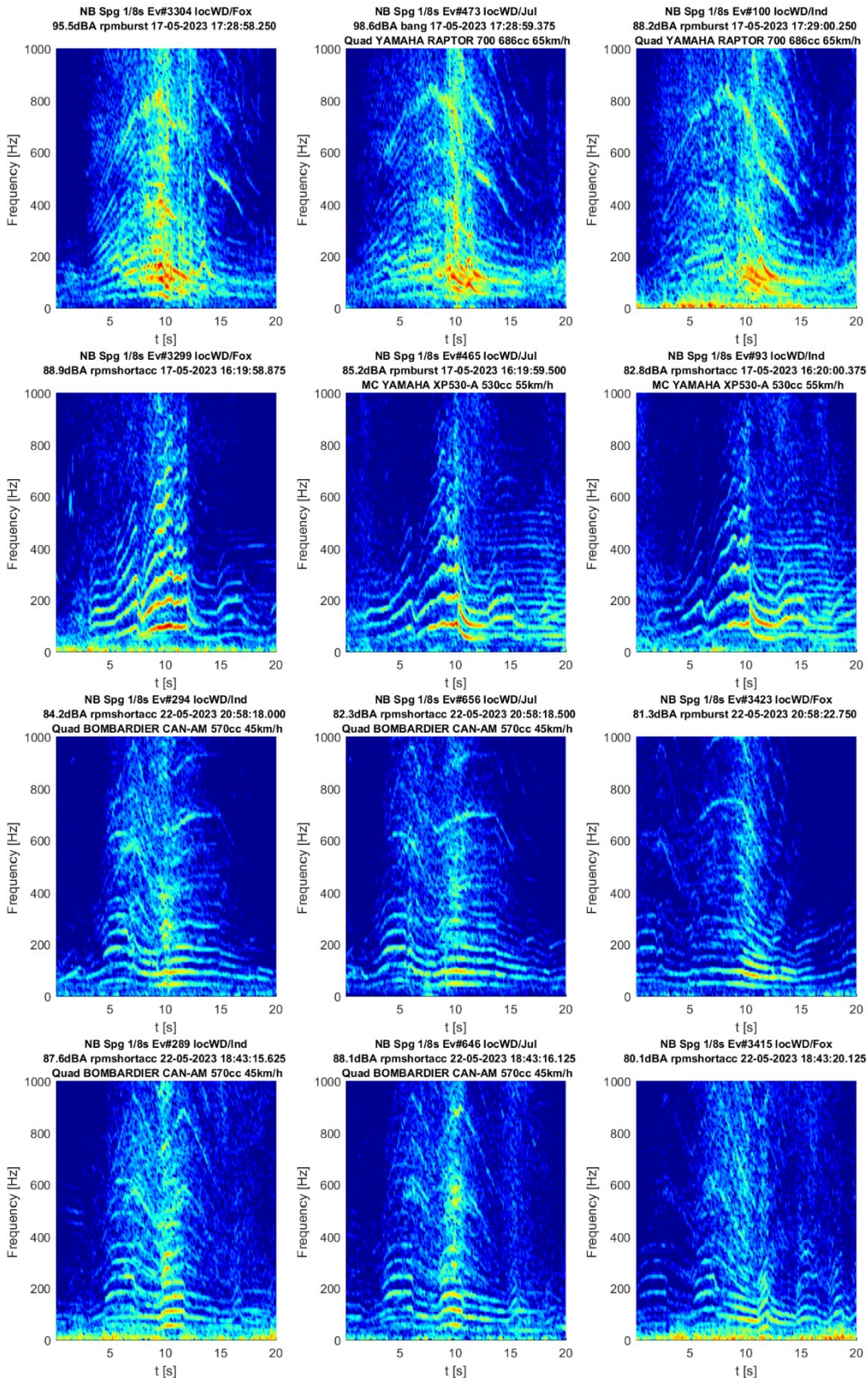

This project has received funding from the European Union's Horizon Europe research and innovation programme under grant agreement No 101056777

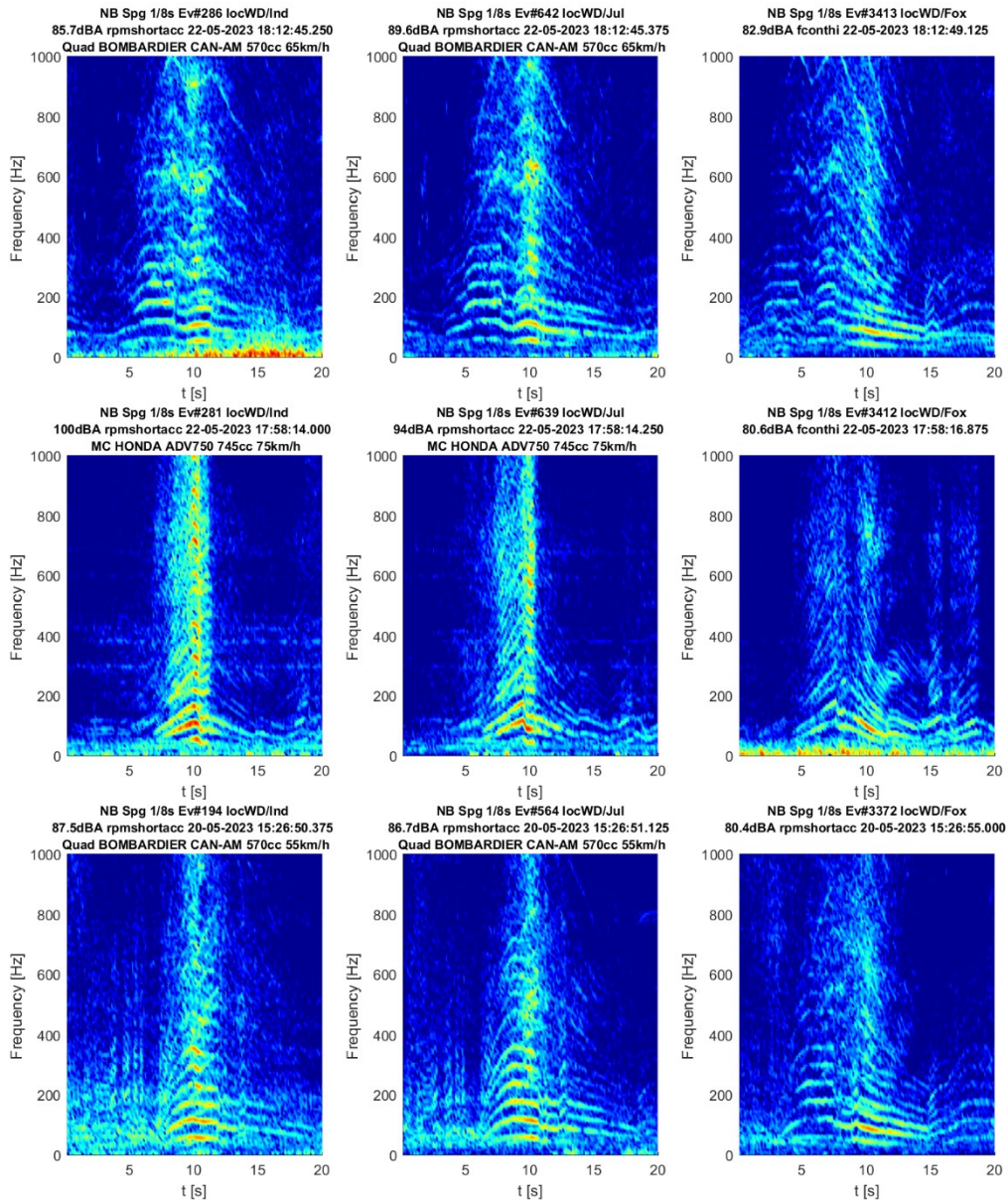

This project has received funding from the European Union's Horizon Europe research and innovation programme under grant agreement No 101056777

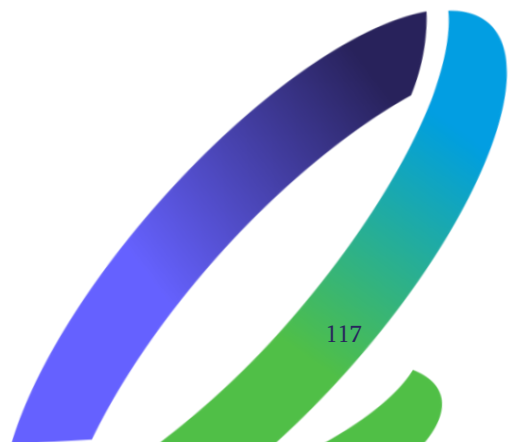

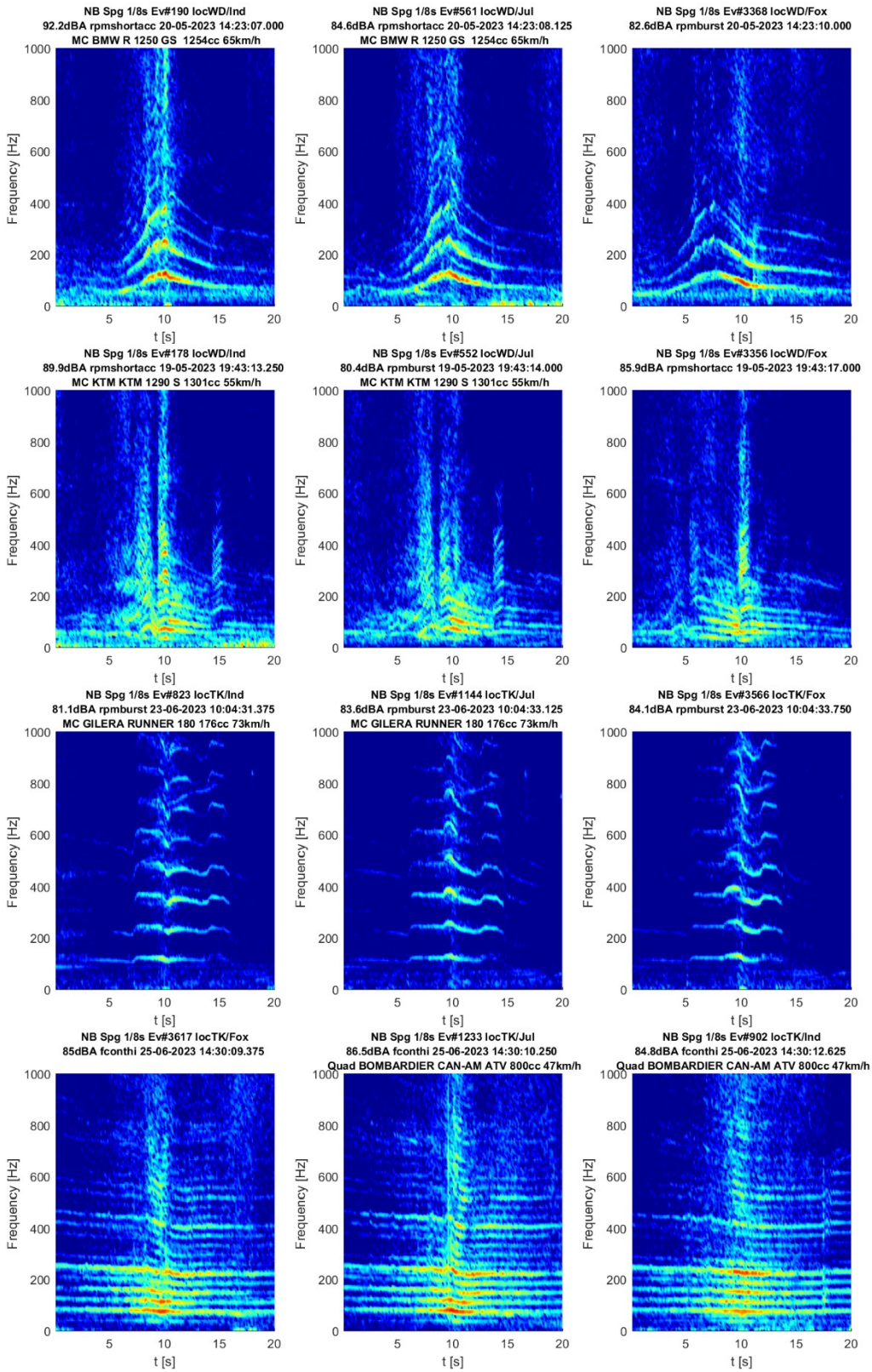

This project has received funding from the European Union's Horizon Europe research and innovation programme under grant agreement No 101056777

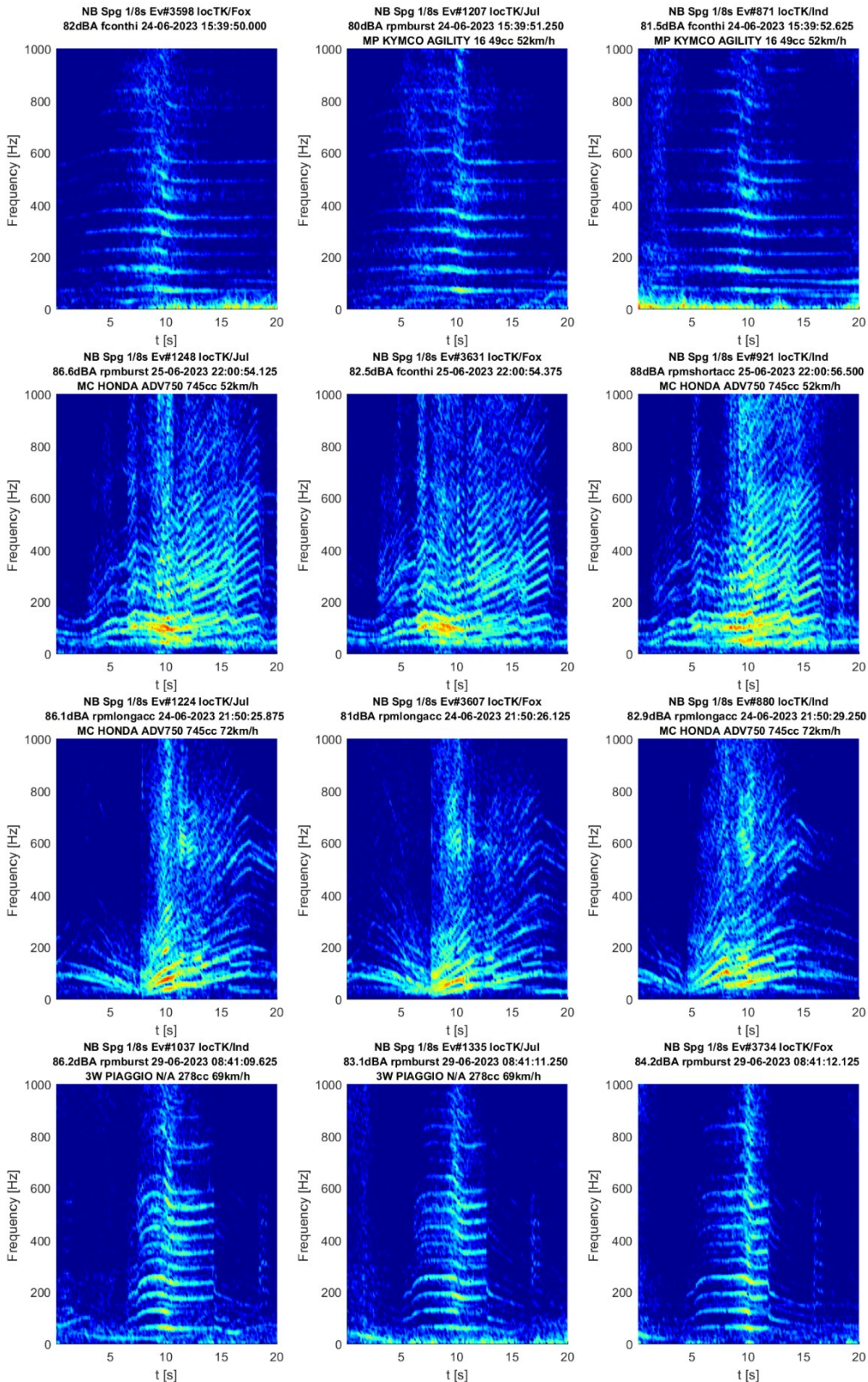

This project has received funding from the European Union's Horizon Europe research and innovation programme under grant agreement No 101056777

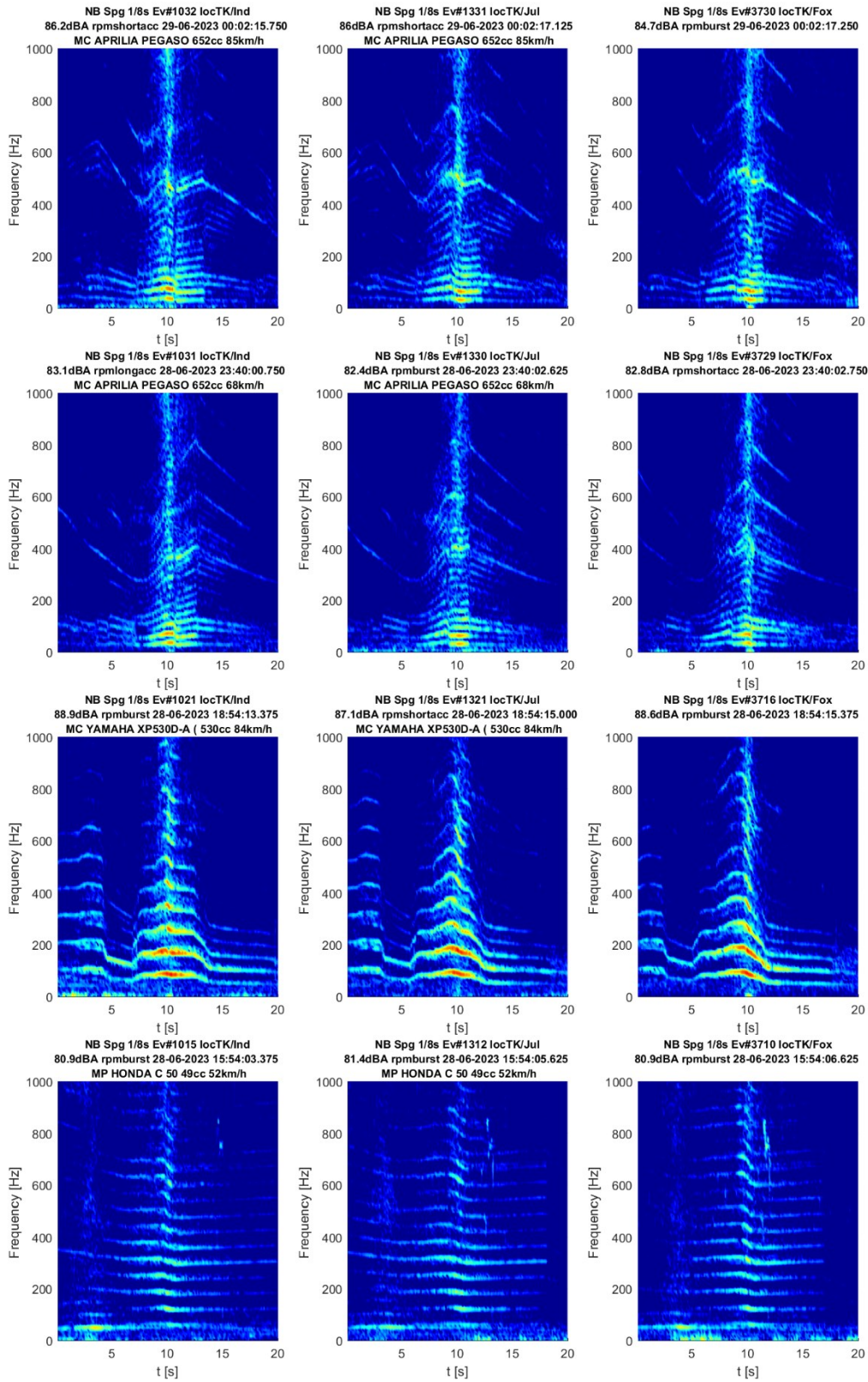

This project has received funding from the European Union's Horizon Europe research and innovation programme under grant agreement No 101056777

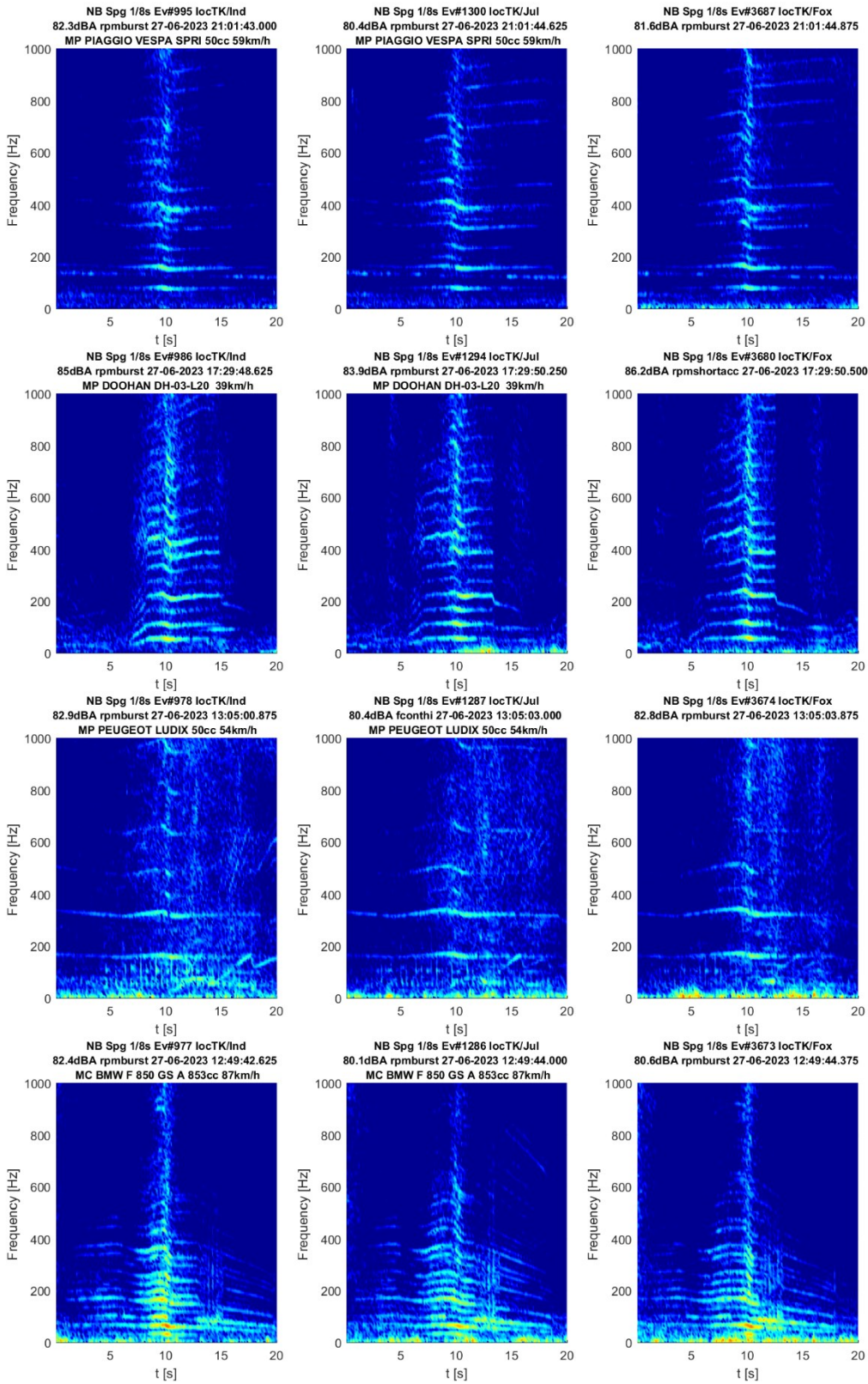

This project has received funding from the European Union's Horizon Europe research and innovation programme under grant agreement No 101056777

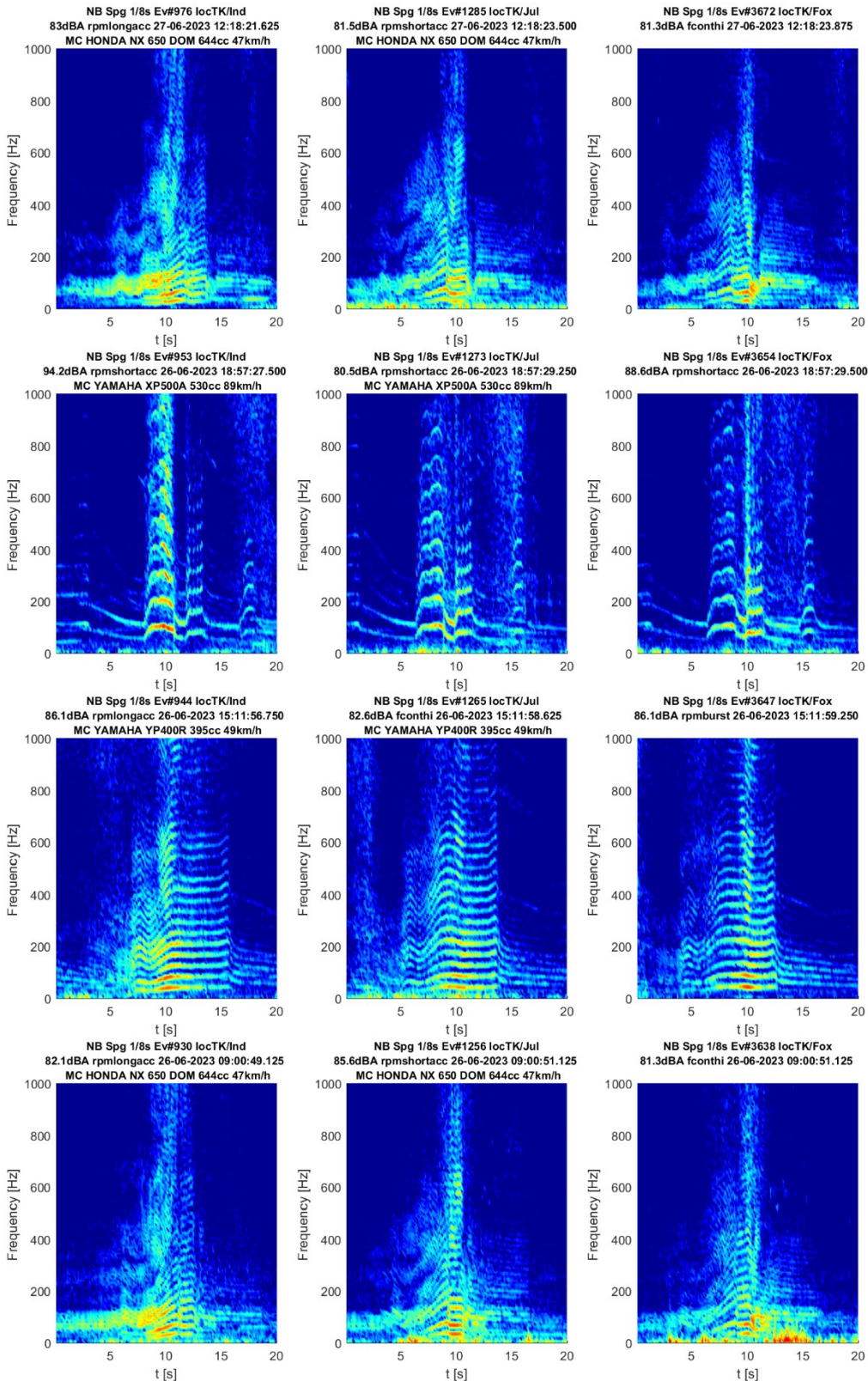

This project has received funding from the European Union's Horizon Europe research and innovation programme under grant agreement No 101056777

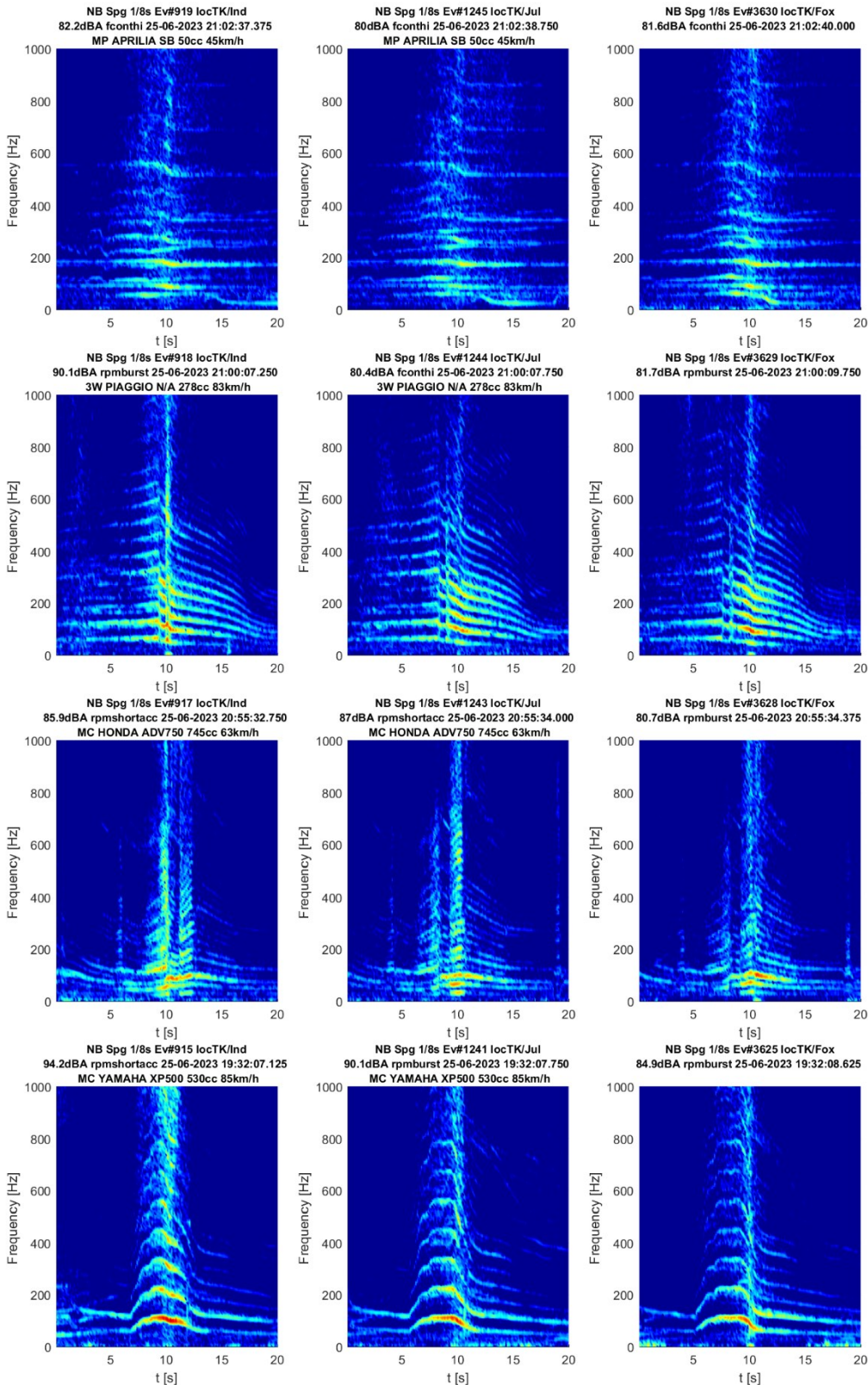

This project has received funding from the European Union's Horizon Europe research and innovation programme under grant agreement No 101056777

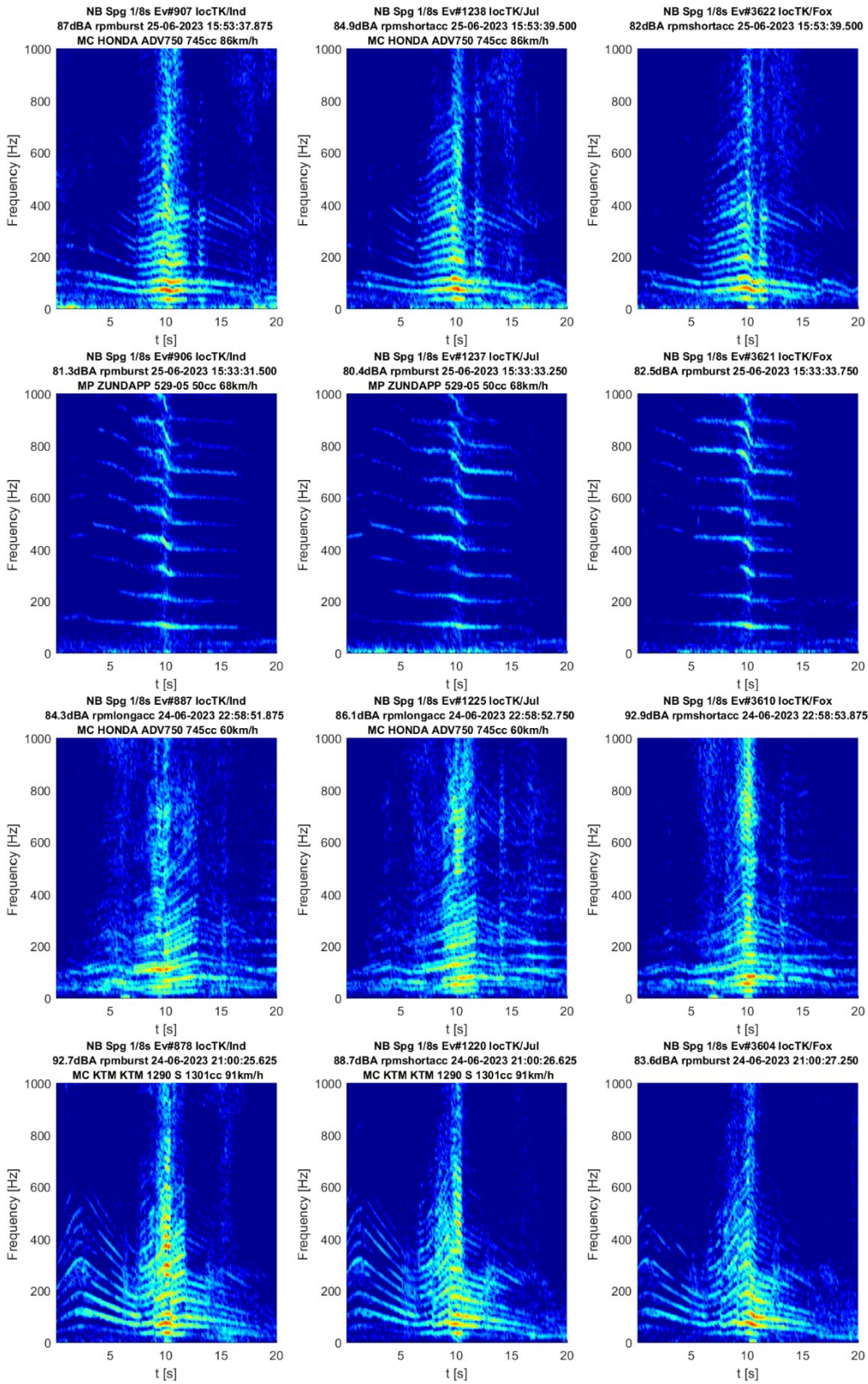

This project has received funding from the European Union's Horizon Europe research and innovation programme under grant agreement No 101056777

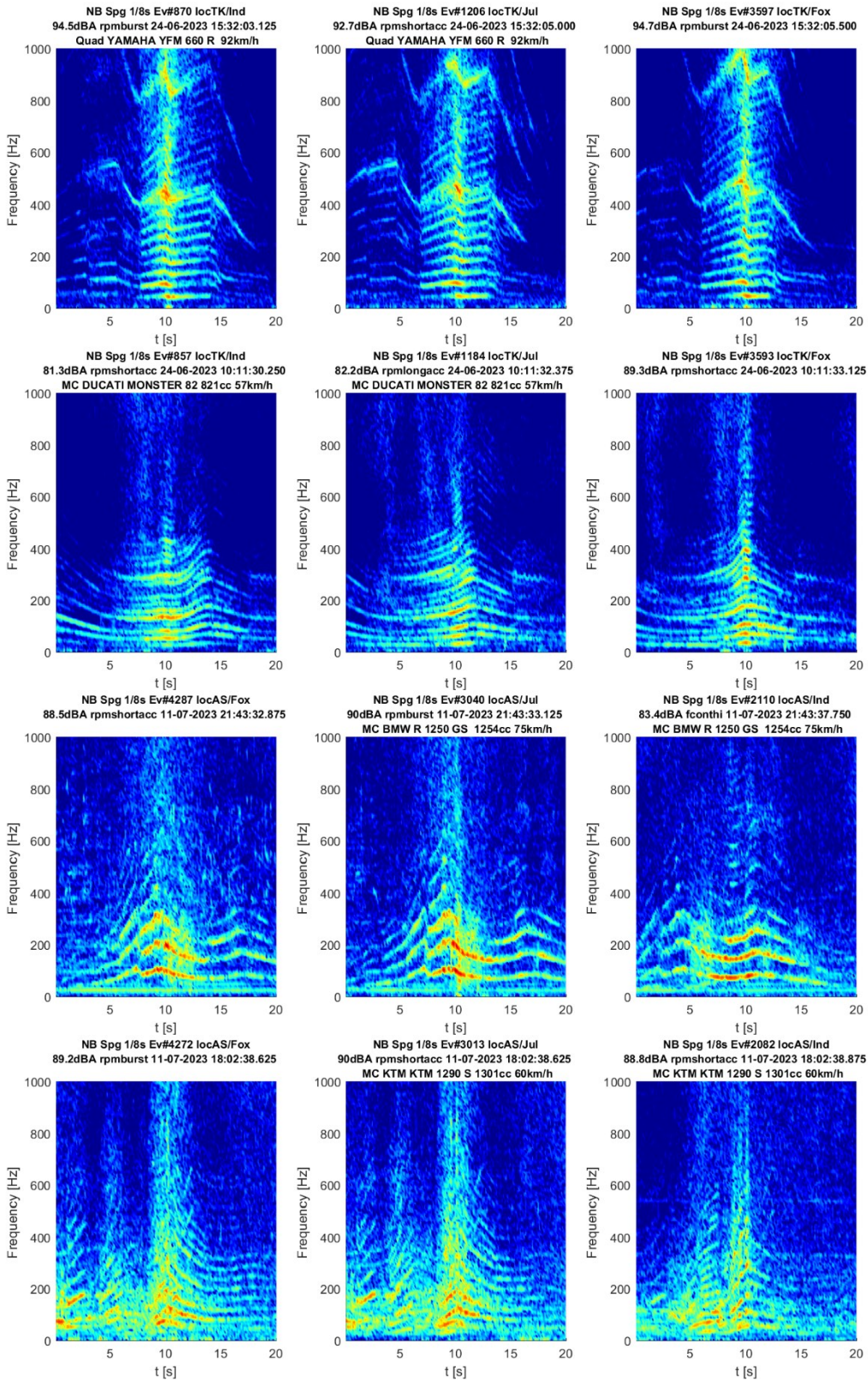

This project has received funding from the European Union's Horizon Europe research and innovation programme under grant agreement No 101056777

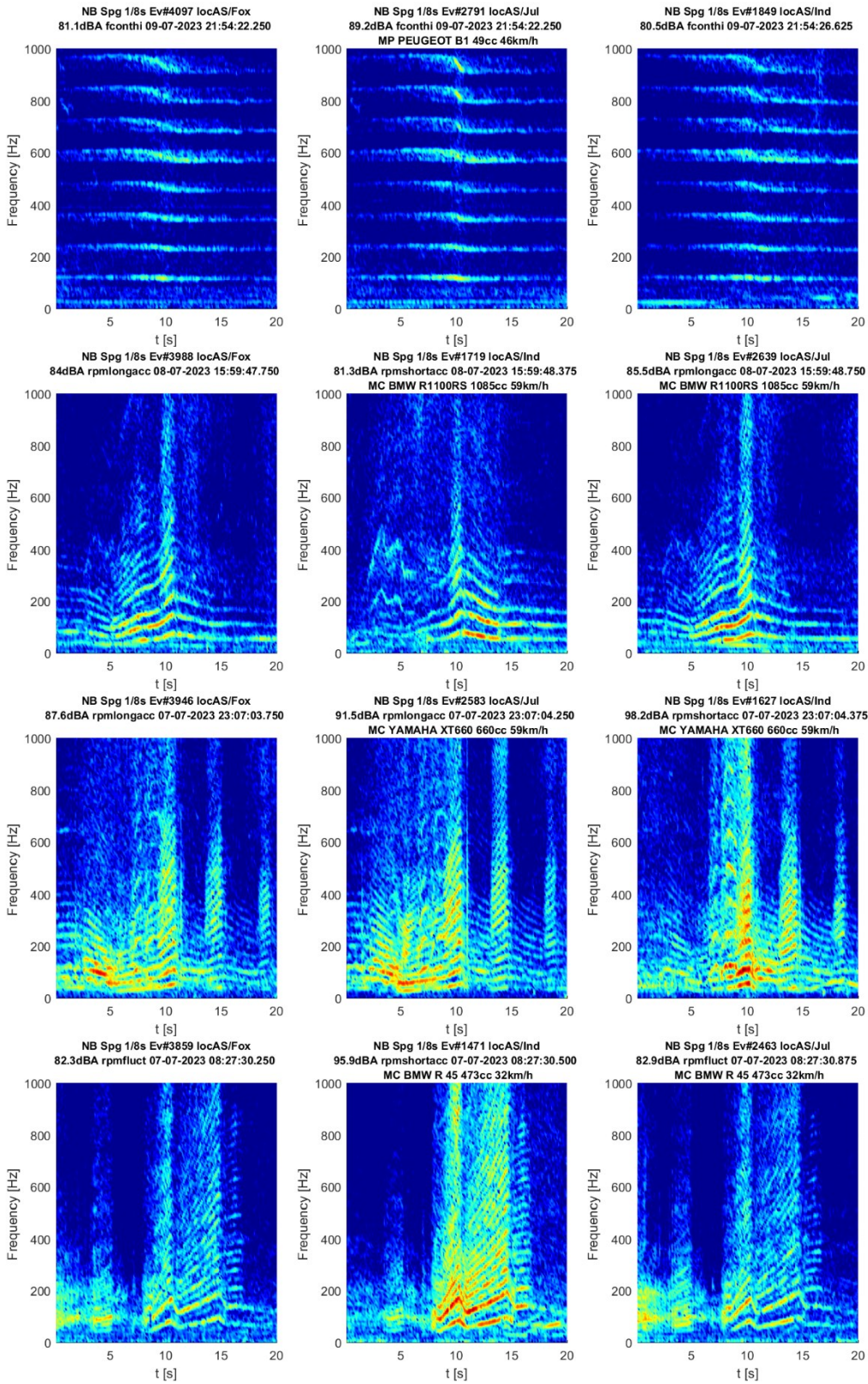

This project has received funding from the European Union's Horizon Europe research and innovation programme under grant agreement No 101056777

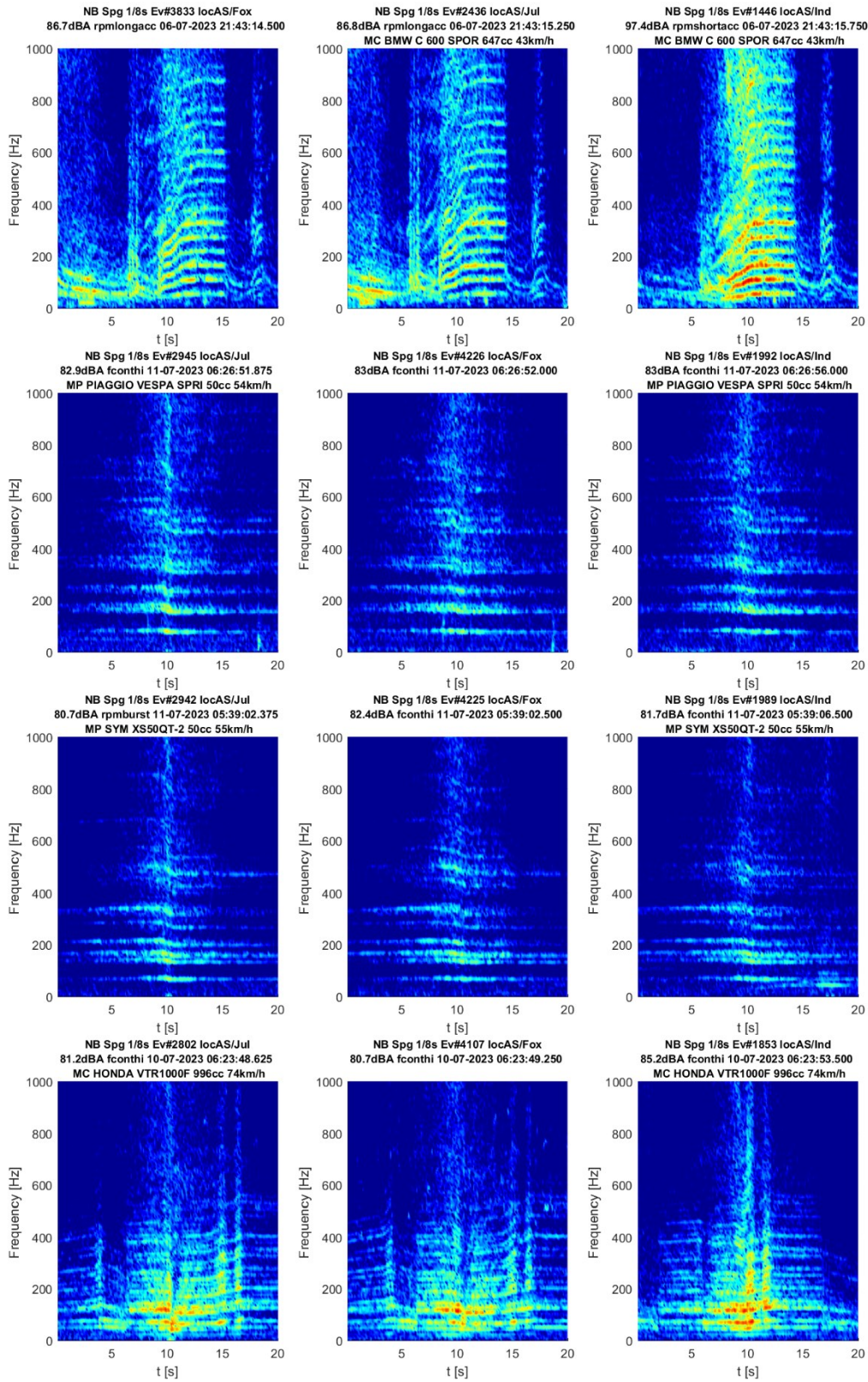

This project has received funding from the European Union's Horizon Europe research and innovation programme under grant agreement No 101056777

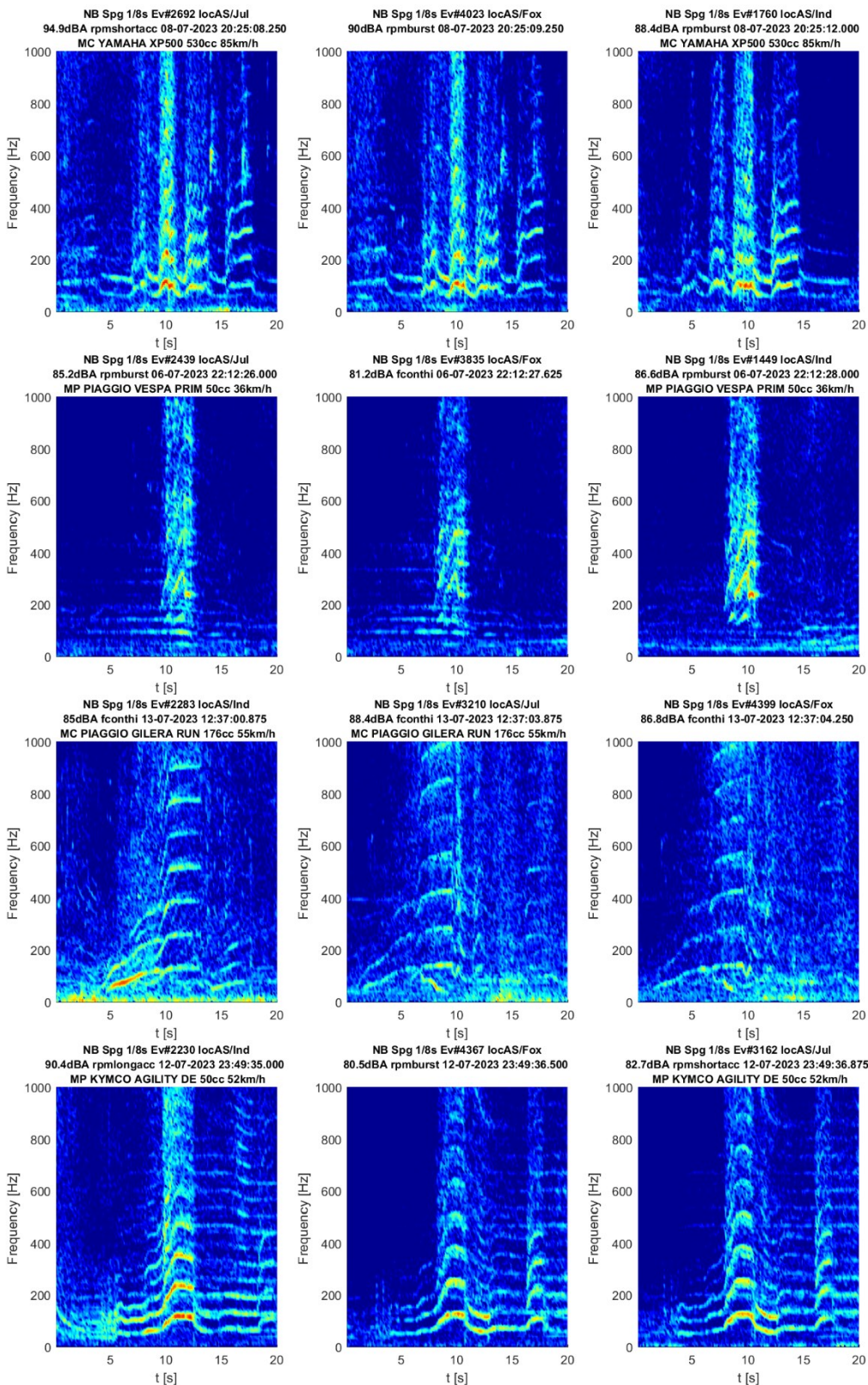

This project has received funding from the European Union's Horizon Europe research and innovation programme under grant agreement No 101056777

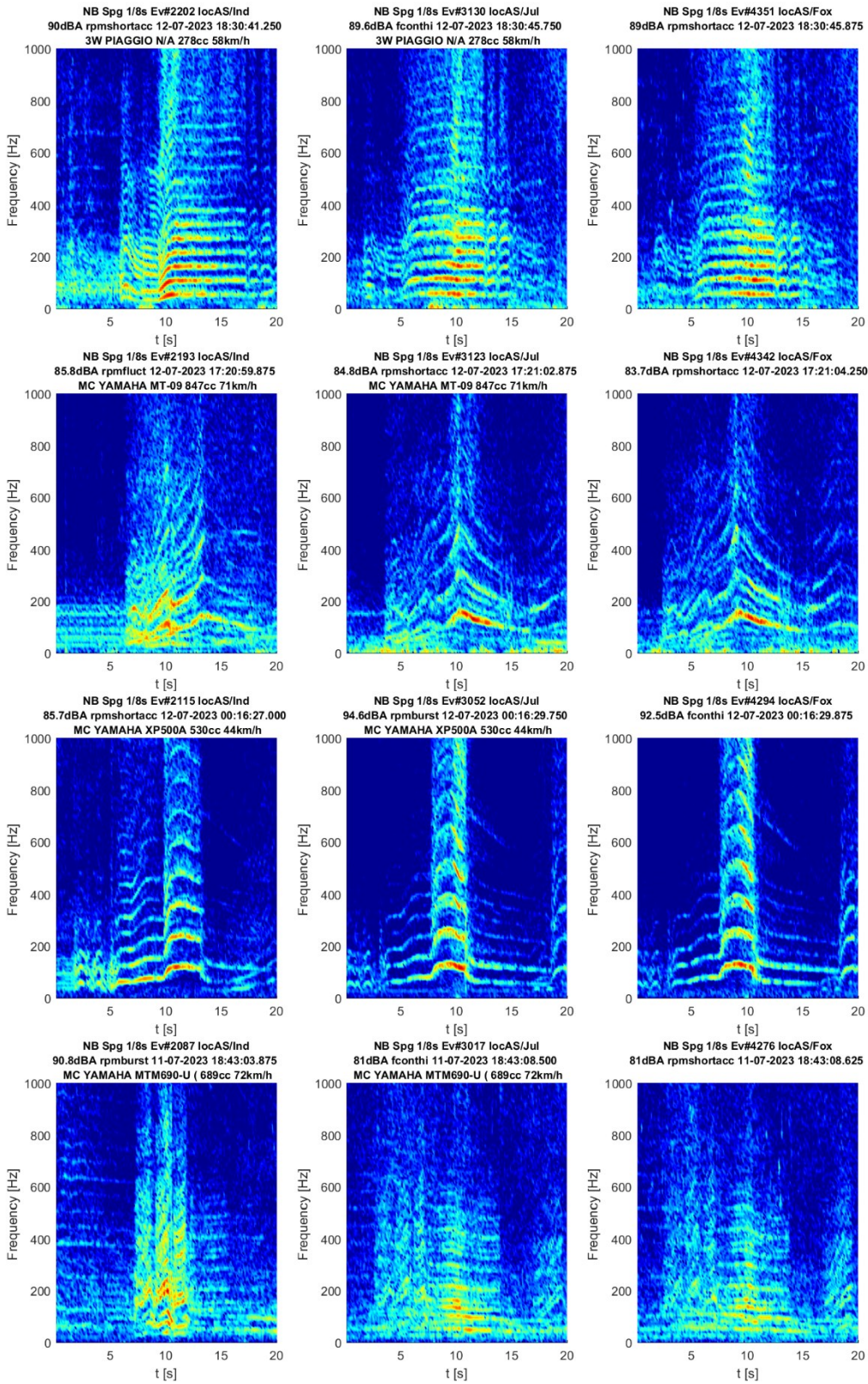

This project has received funding from the European Union's Horizon Europe research and innovation programme under grant agreement No 101056777

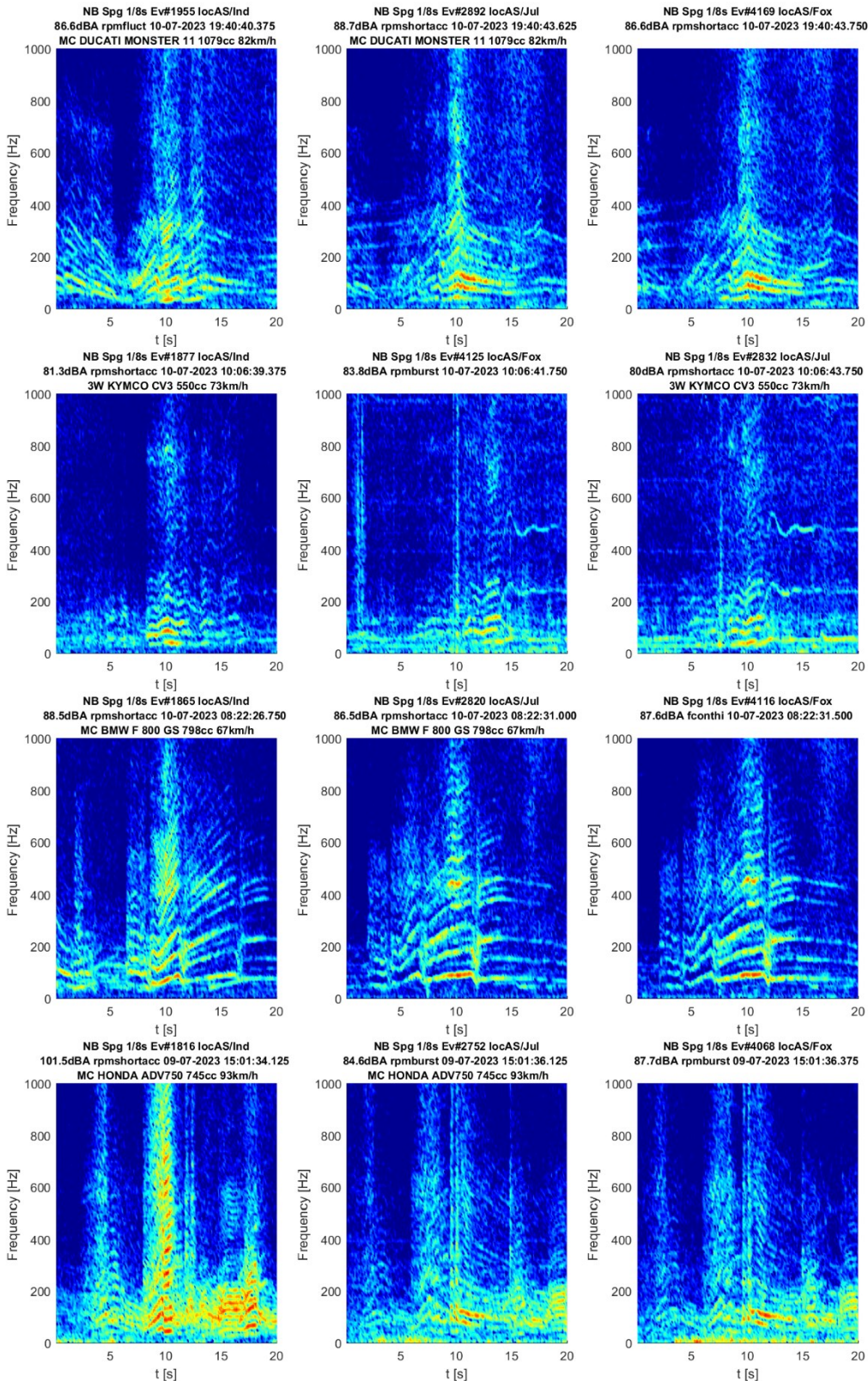

This project has received funding from the European Union's Horizon Europe research and innovation programme under grant agreement No 101056777

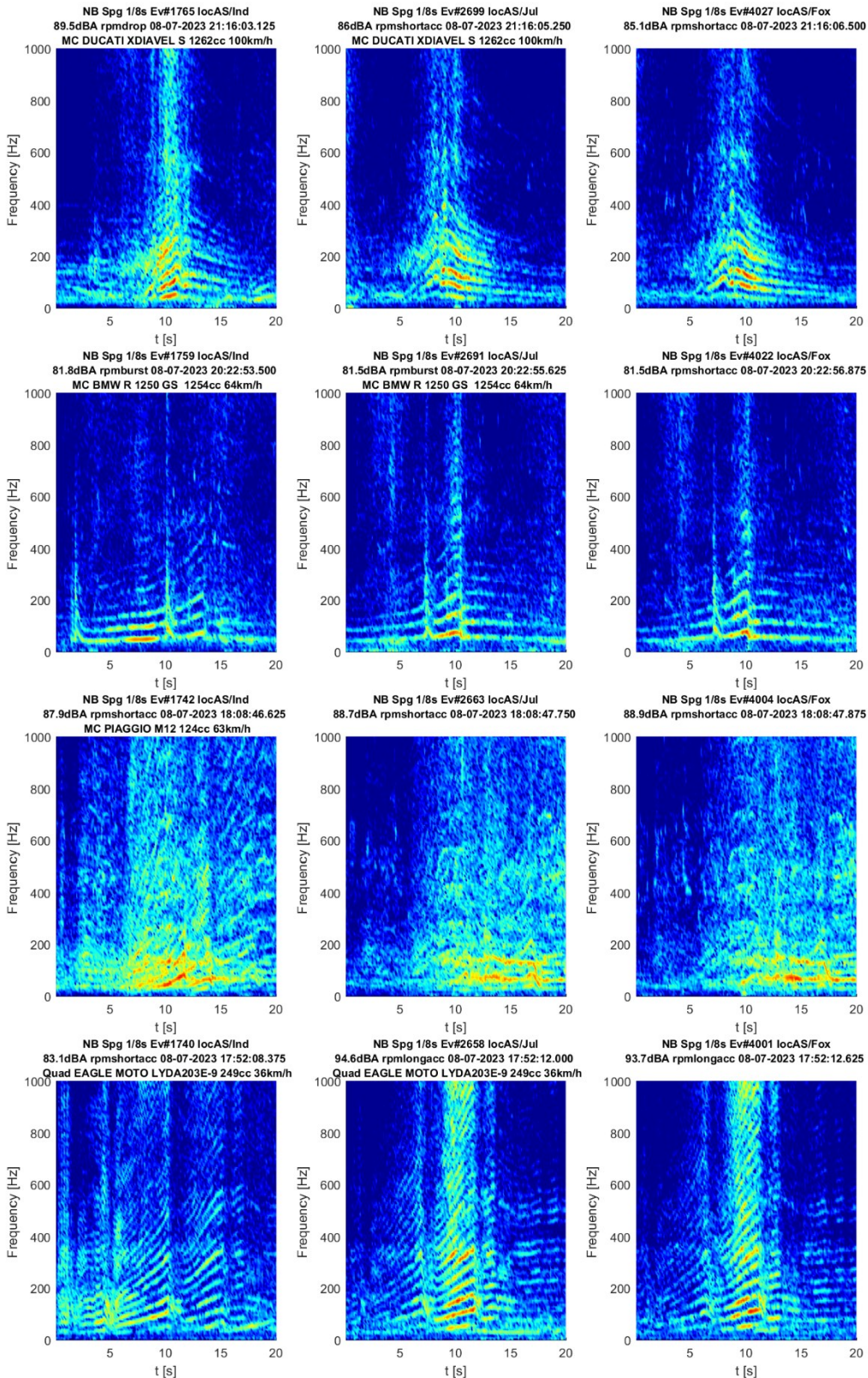

This project has received funding from the European Union's Horizon Europe research and innovation programme under grant agreement No 101056777

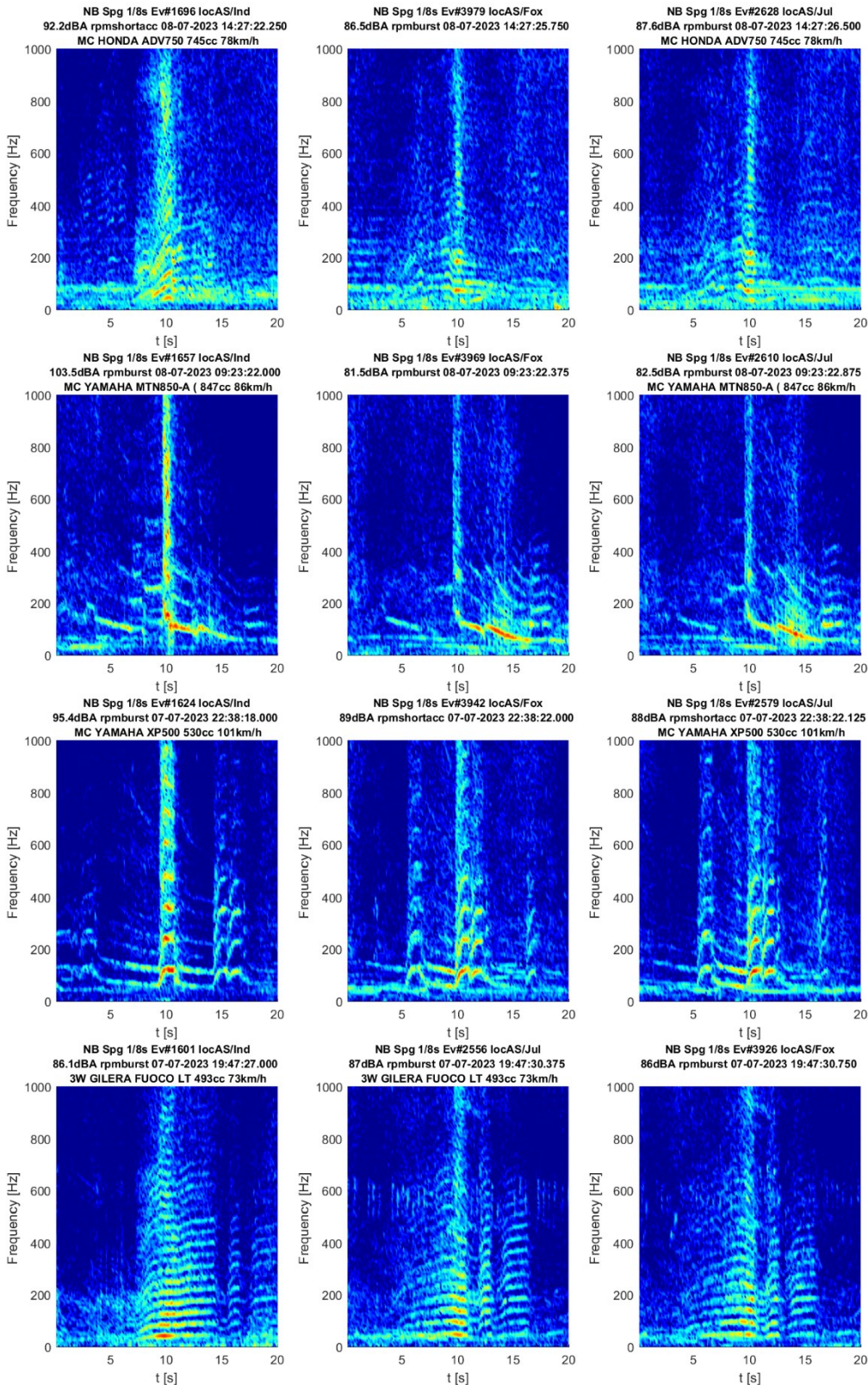

This project has received funding from the European Union's Horizon Europe research and innovation programme under grant agreement No 101056777

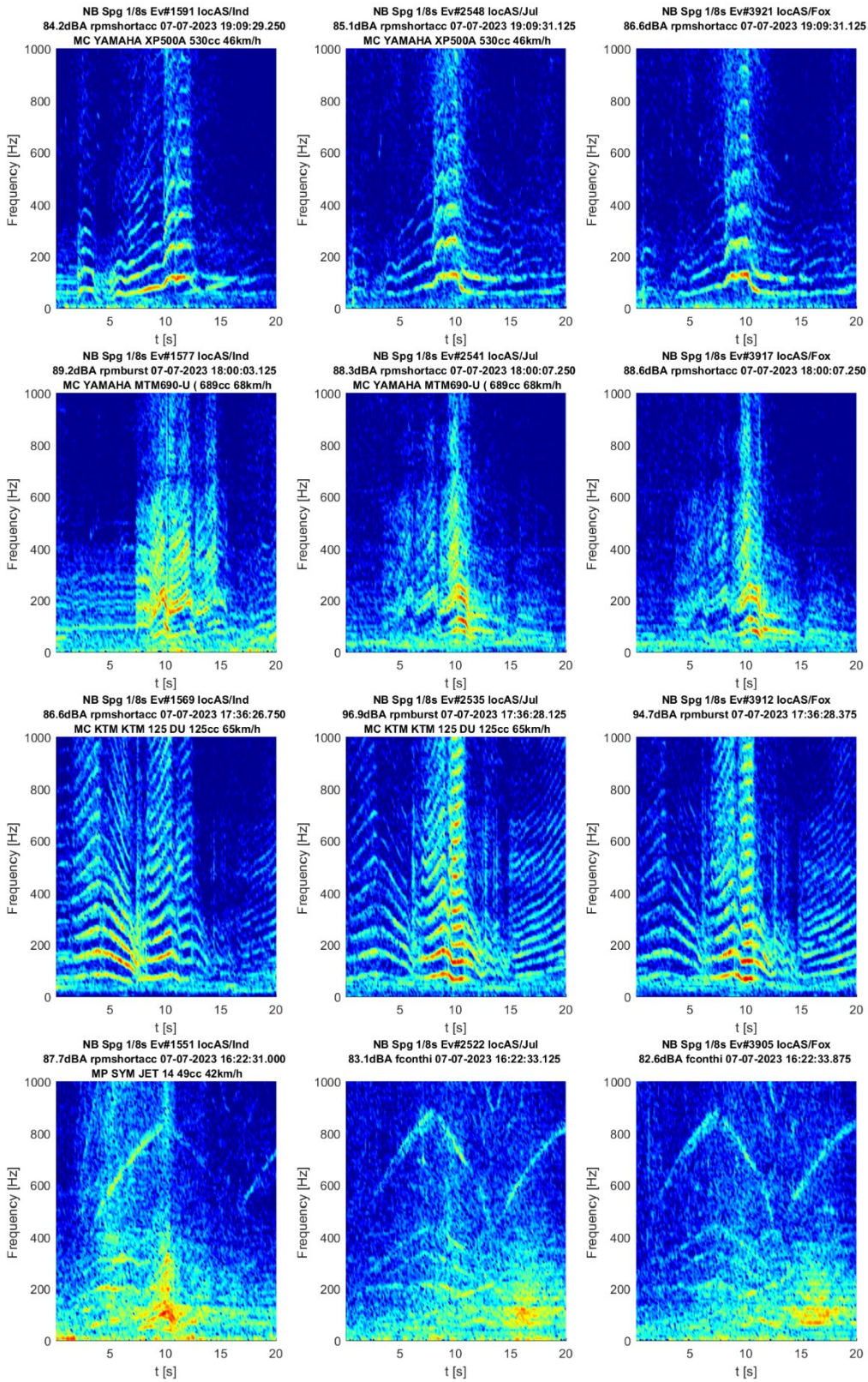

This project has received funding from the European Union's Horizon Europe research and innovation programme under grant agreement No 101056777

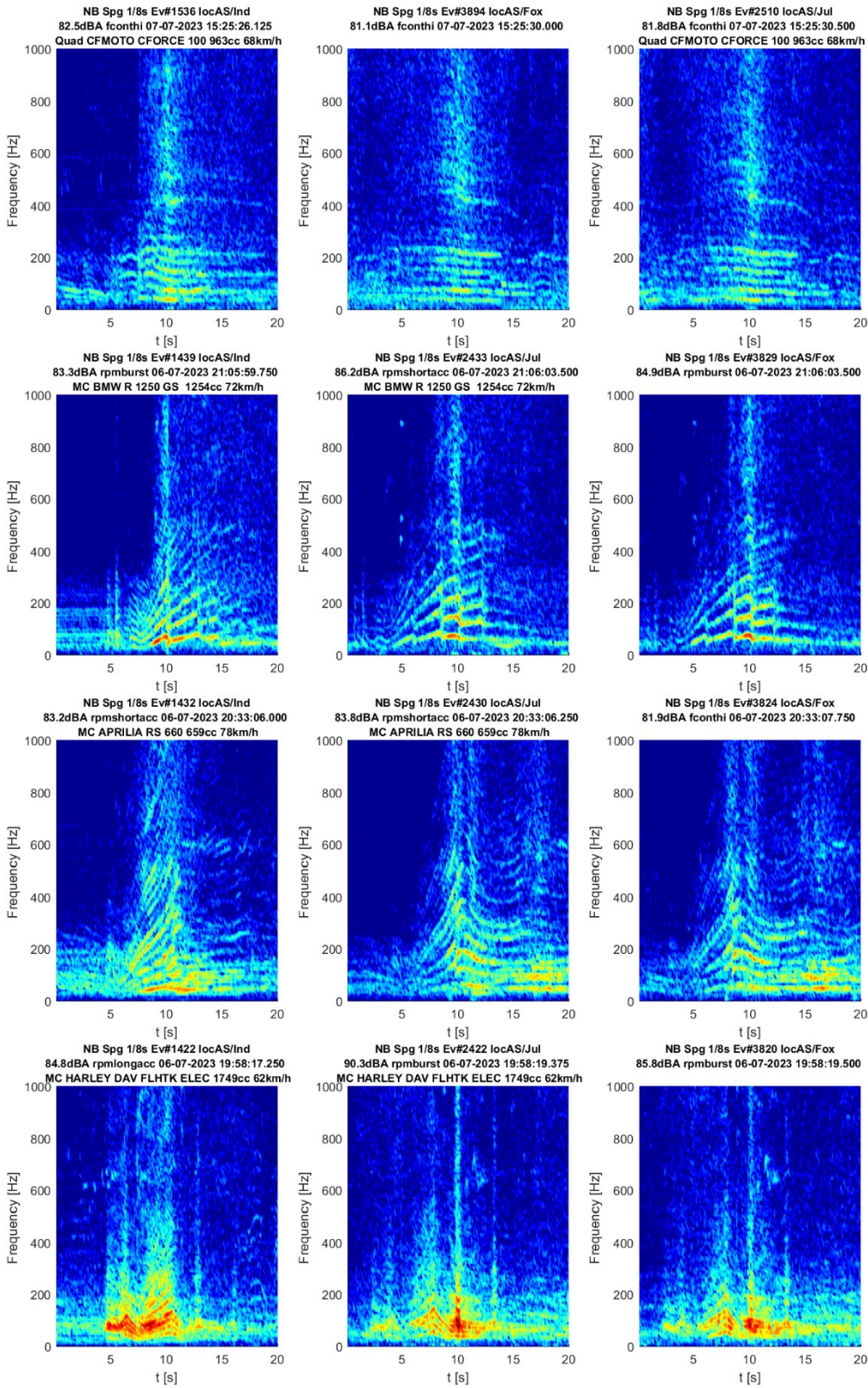

This project has received funding from the European Union's Horizon Europe research and innovation programme under grant agreement No 101056777

Annex C Additional vehicle emission data

Additional plots of vehicle pollutant emissions

CO emissions of a moped

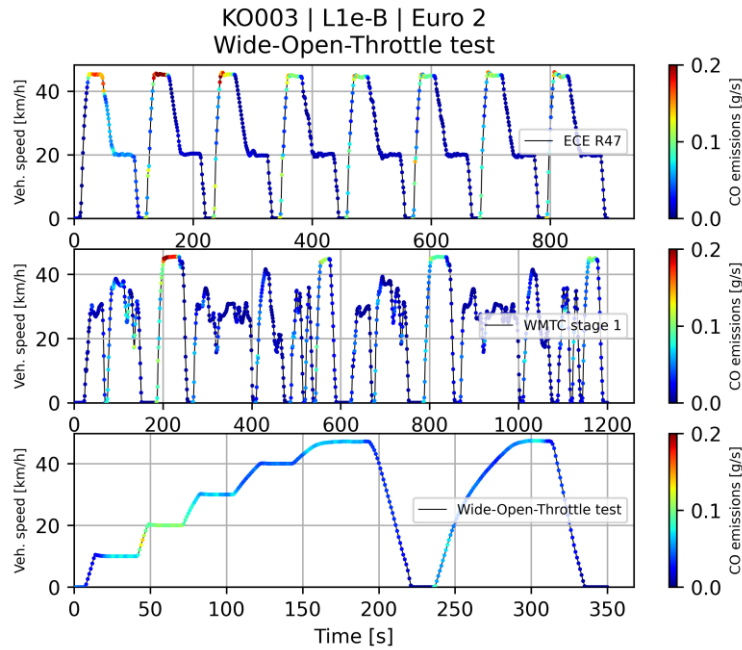

Figure C-1: Overview of CO emissions of different test cycles

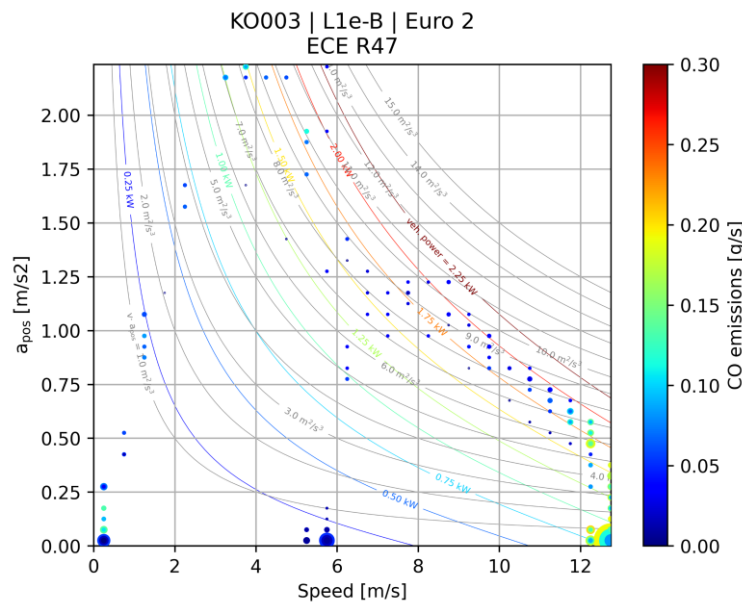

Figure C-2: CO emission map (whole test)



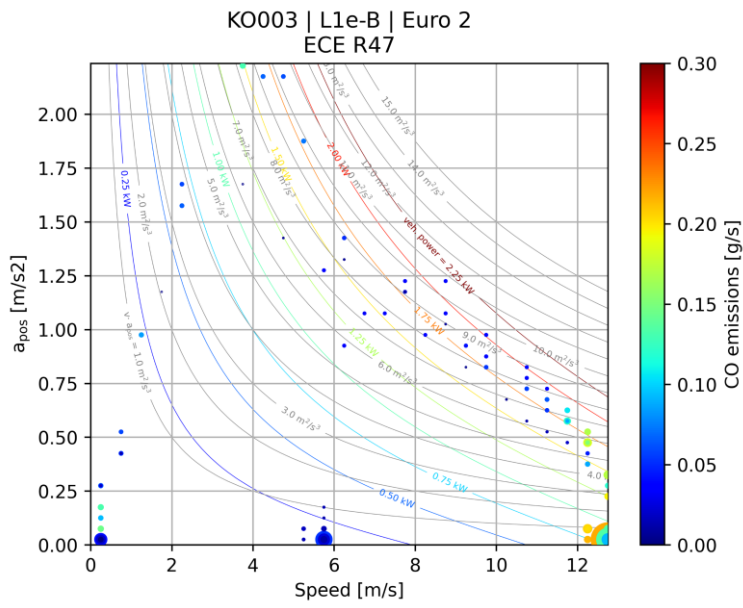

Figure C-3: CO emission map (cold phase)

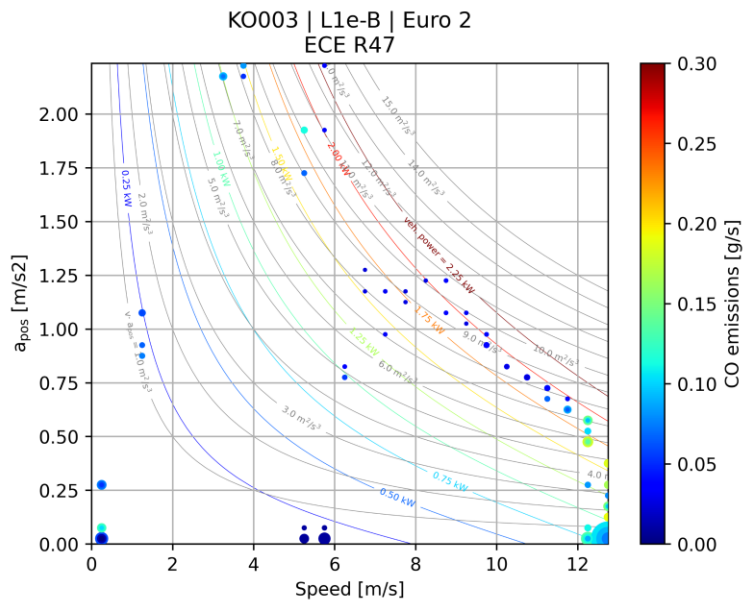

Figure C-4: CO emission map (warm phase)



This project has received funding from the European Union's Horizon Europe research and innovation programme under grant agreement No 101056777

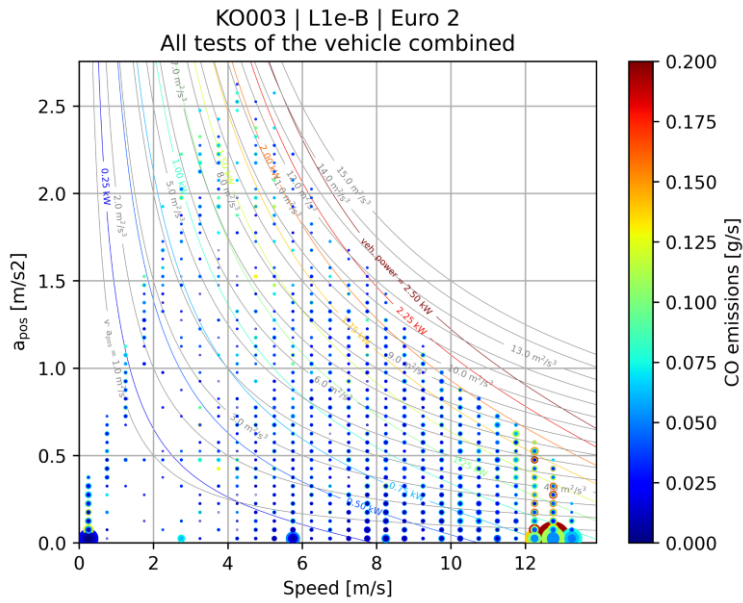

Figure C-5: CO emission map (all tests combined)

HC emissions of a moped

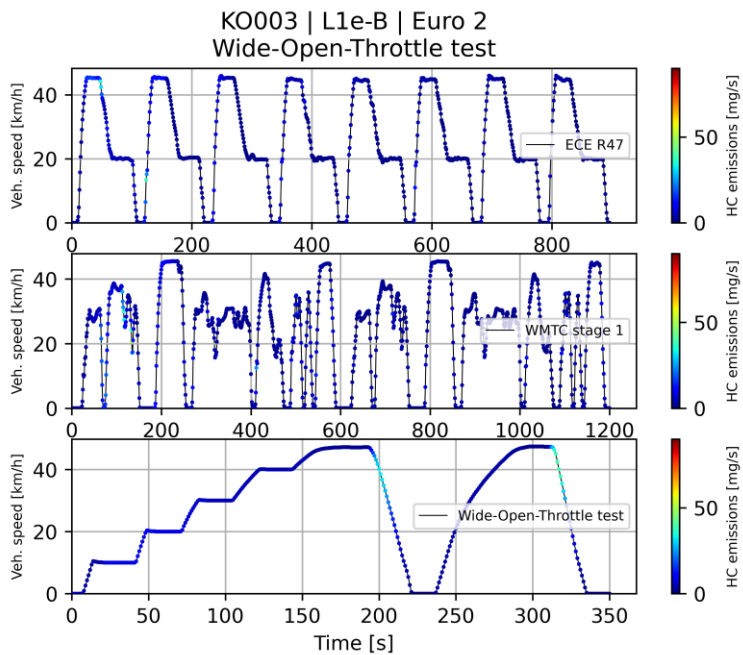

Figure C-6: Overview of HC emissions of different test cycles



This project has received funding from the European Union's Horizon Europe research and innovation programme under grant agreement No 101056777

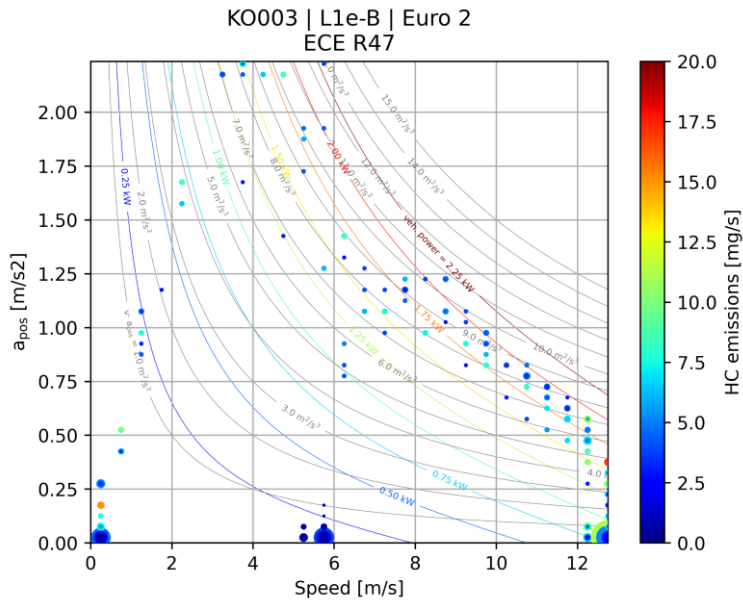

Figure C-7: HC emission map (whole test)

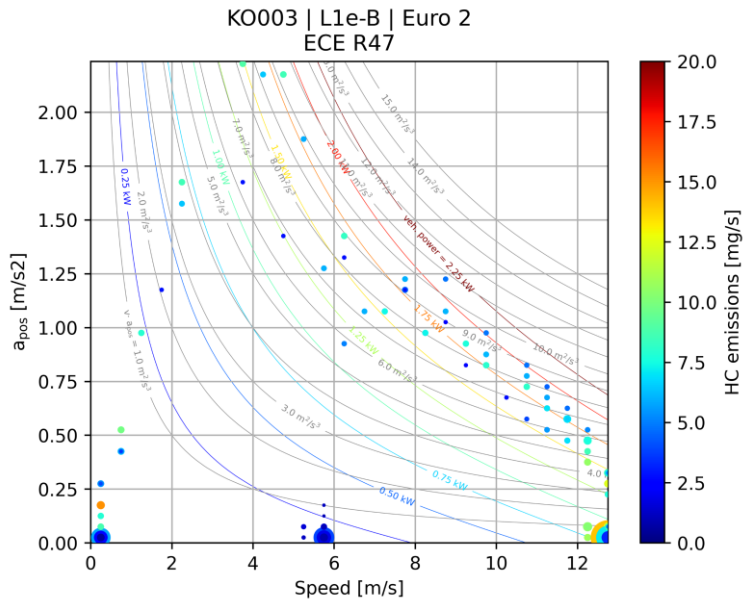

Figure C-8: HC emission map (cold phase)



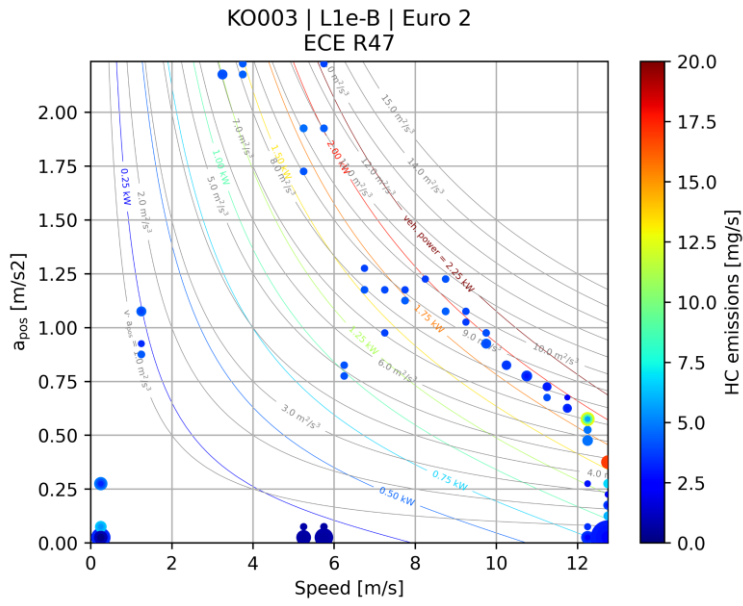

Figure C-9: HC emission map (warm phase)

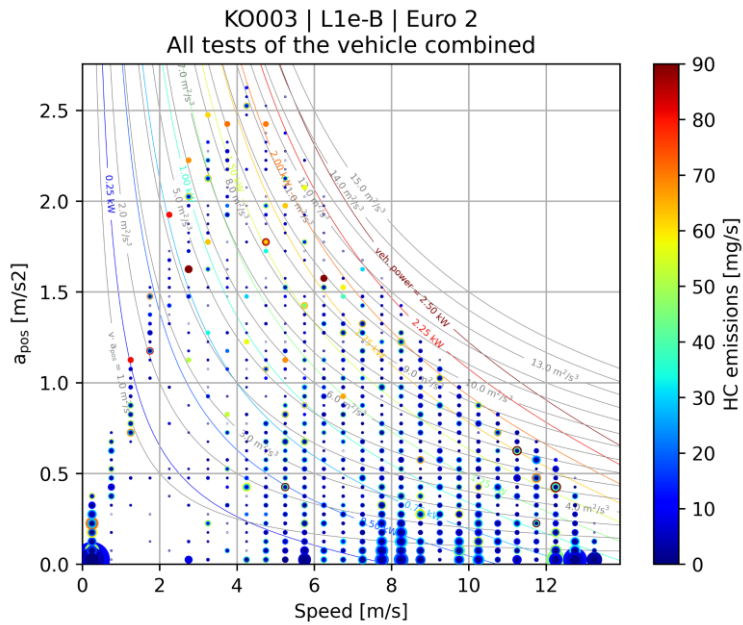

Figure C-10: HC emission map (all tests combined)



CO emissions of a motorcycle

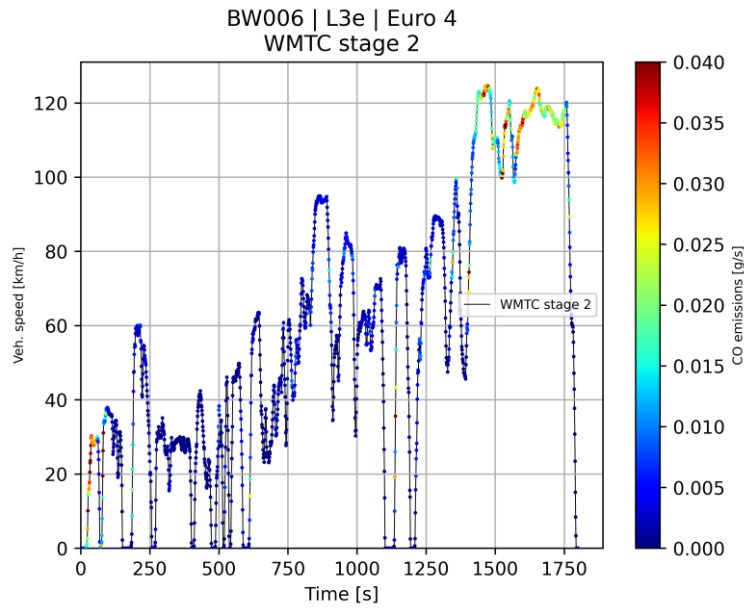

Figure C-11: Overview of CO emissions

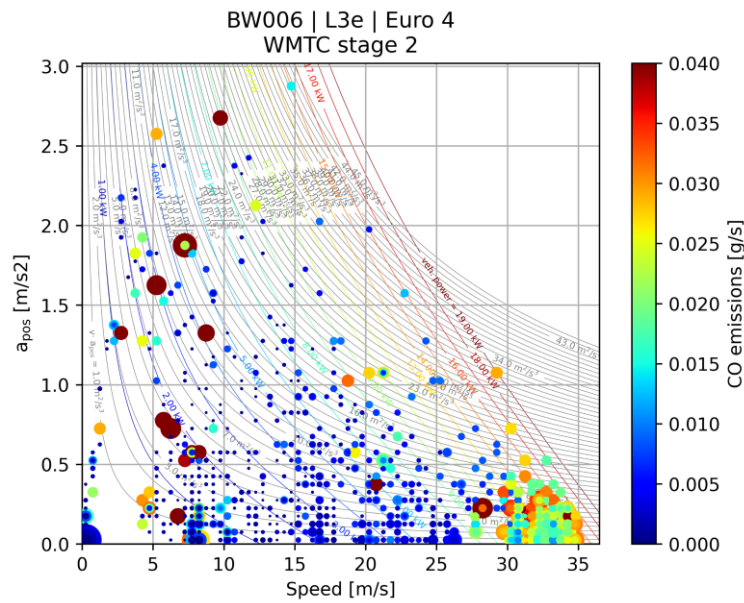

Figure C-12: CO emission map (whole test)



This project has received funding from the European Union's Horizon Europe research and innovation programme under grant agreement No 101056777

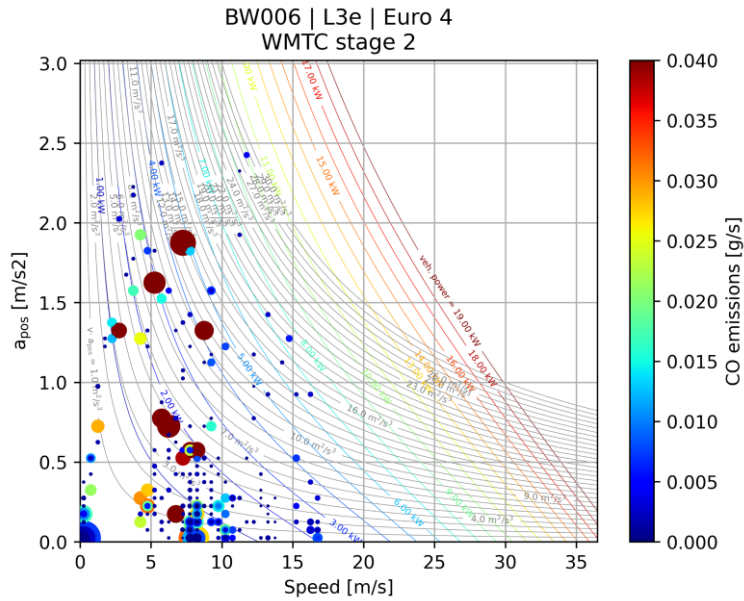

Figure C-13: CO emission map (cold phase)

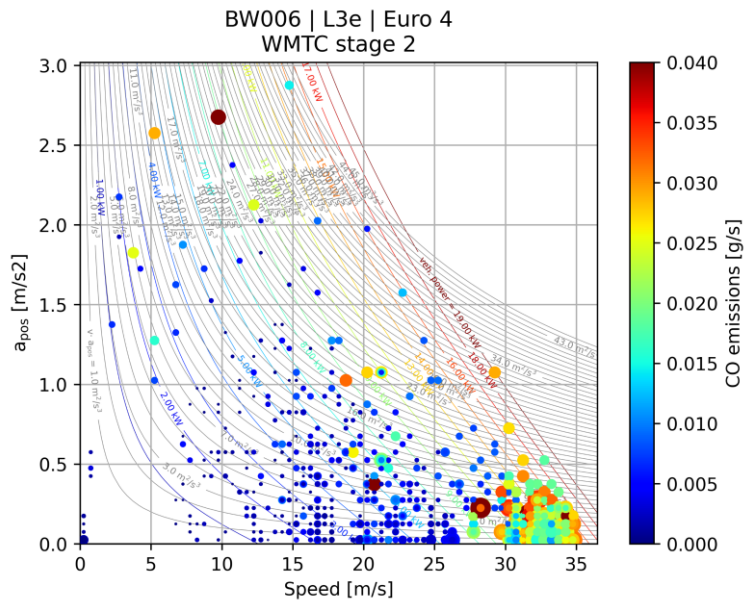

Figure C-14: CO emission map (warm phase)



This project has received funding from the European Union's Horizon Europe research and innovation programme under grant agreement No 101056777

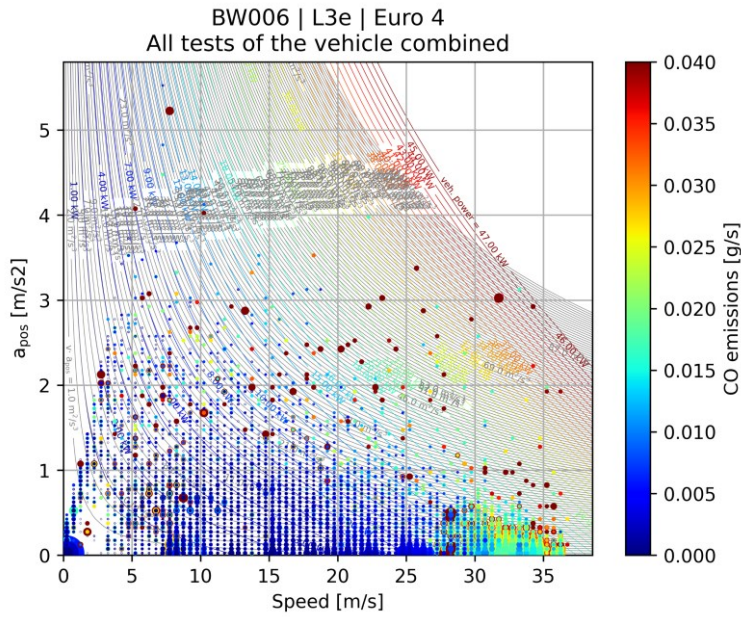

Figure C-15: CO emission map (all tests combined)

HC emissions of a motorcycle

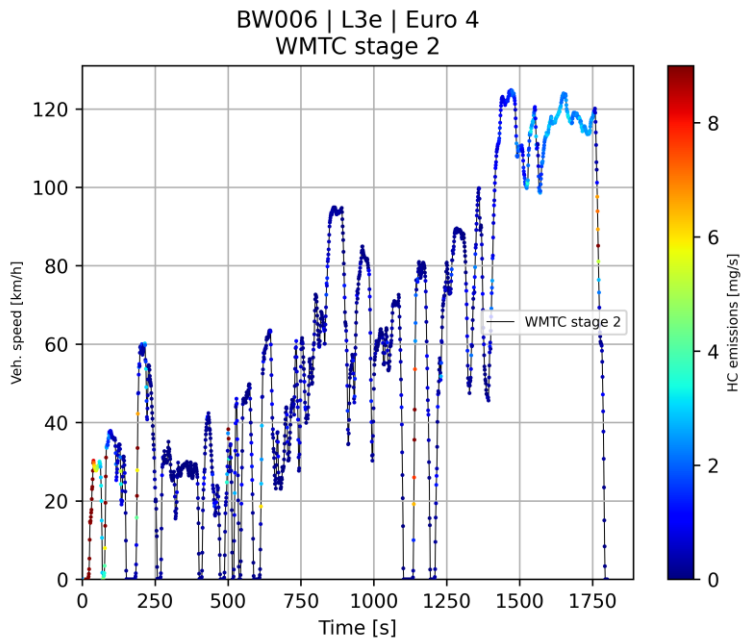

Figure C-16: Overview of HC emissions



This project has received funding from the European Union's Horizon Europe research and innovation programme under grant agreement No 101056777

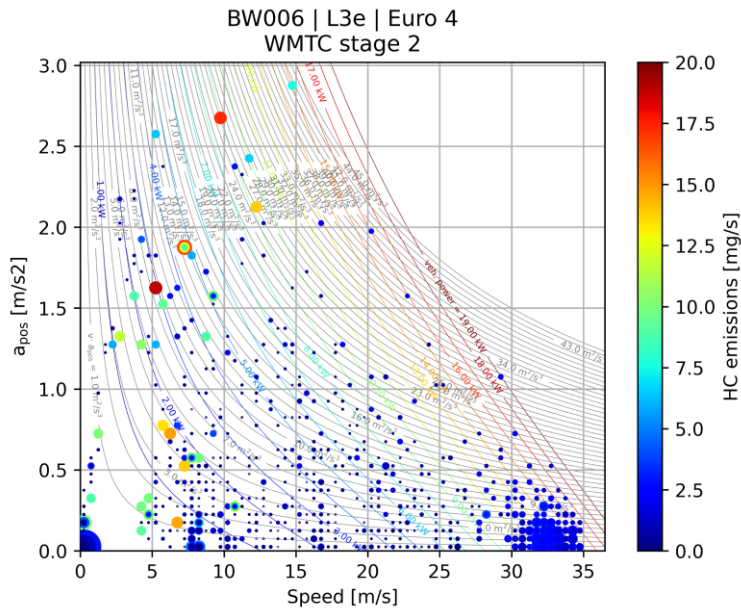

Figure C-17: HC emission map (whole test)

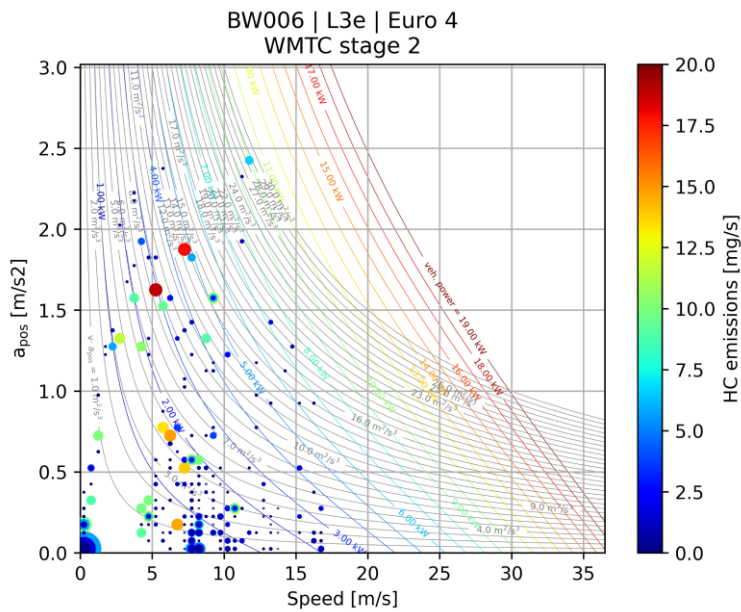

Figure C-18: HC emission map (cold phase)



This project has received funding from the European Union's Horizon Europe research and innovation programme under grant agreement No 101056777

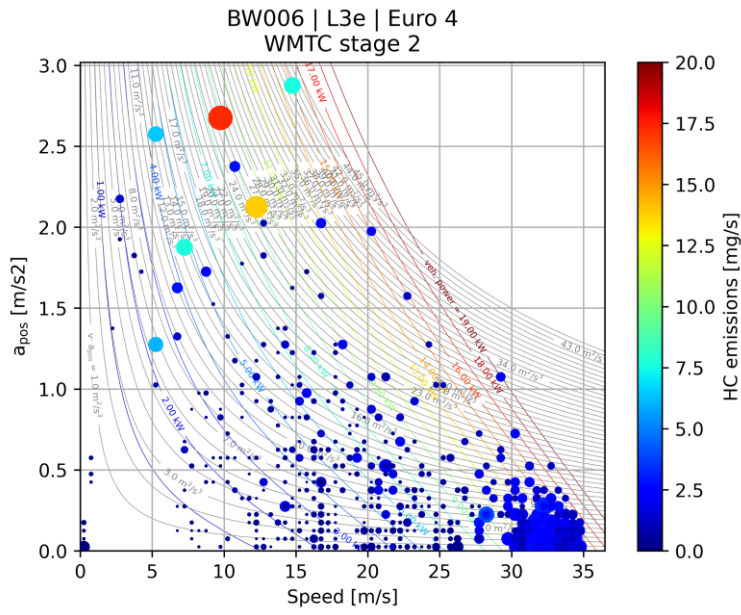

Figure C-19: HC emission map (warm phase)

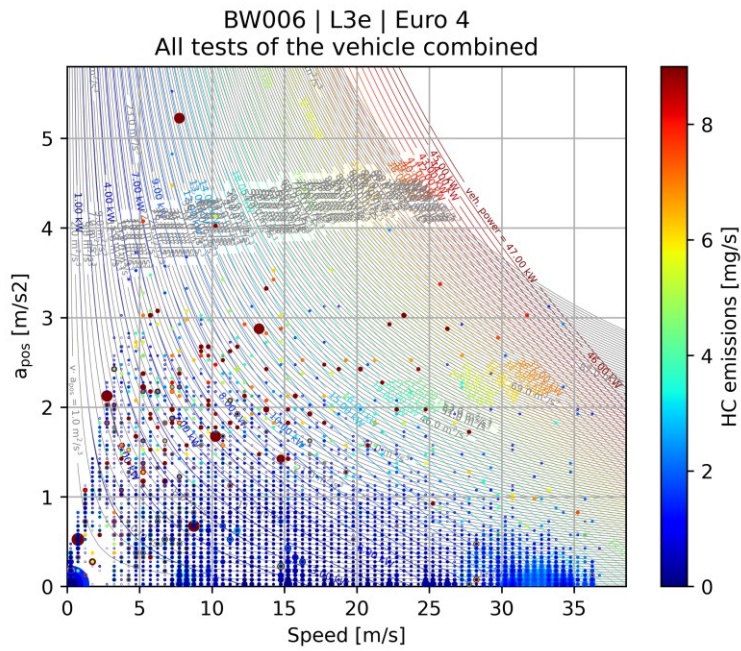

Figure C-20: HC emission map (all tests combined)



This project has received funding from the European Union's Horizon Europe research and innovation programme under grant agreement No 101056777

Results of tests with Micro PEMS

In this annex the results of RDE tests with a Micro PEMS are briefly summarized. It was an experimental test campaign, and therefore the results can only be considered indicative. The Micro PEMS used was capable of measuring the concentrations of NO, CO, CO₂ and hydrocarbons (hexane). Furthermore, engine and GPS data could be logged. Some compromises were made to keep the PEMS small and light, like no direct exhaust flow measurement, no heated lines and different analysers. The PEMS applied in this particular study did not reached the accuracy and applicability as the PEMSs which are applied for light- and heavy duty vehicles.

The results of three mopeds were selected to be presented at this point. More information can be found in report “*Effect study of the environmental step Euro 5 for L-category vehicles*” [31].

Different to chassis dyno data the data points are spread over the whole range of possible combinations of speed and acceleration. Similar to the chassis dyno results, high emissions – especially of carbon monoxide – occur at combinations of high speed and high power. The NO data of mopeds B and C show high mass emissions along the line of maximum power, not only at high speeds.

RDE data of moped A

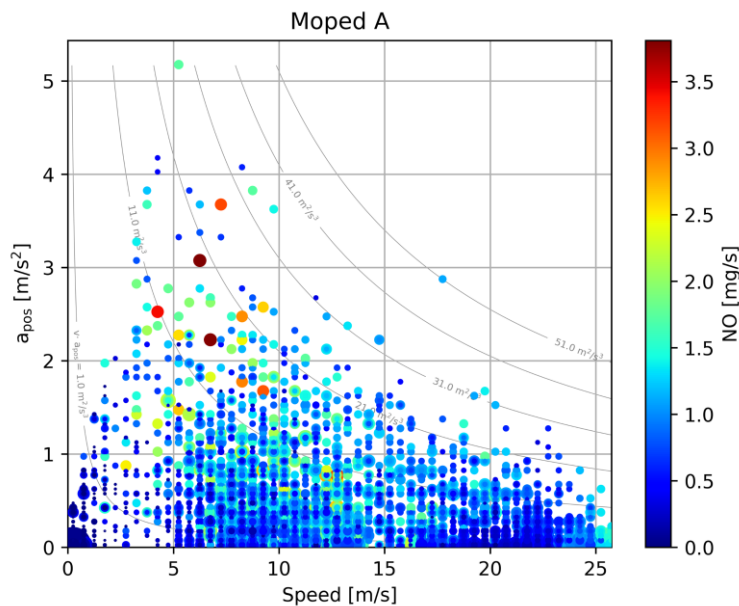

Figure C-21: NO emissions of moped A



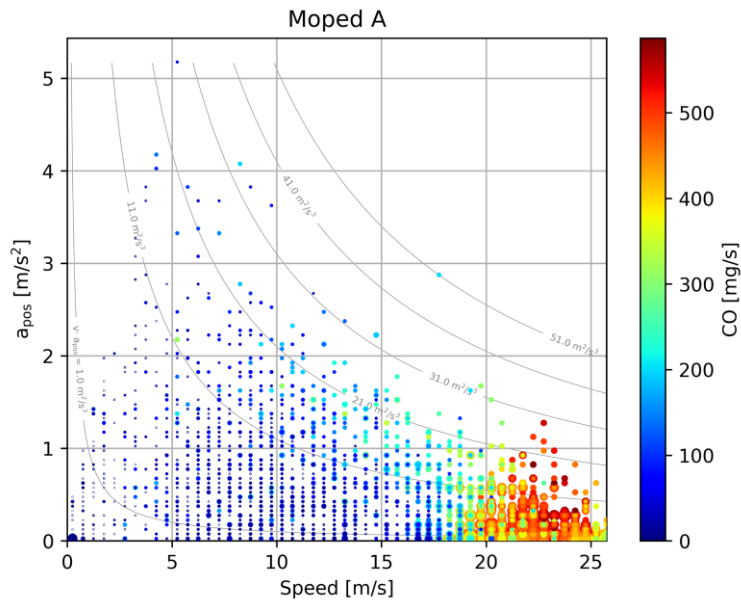

Figure C-22: CO emissions of moped A

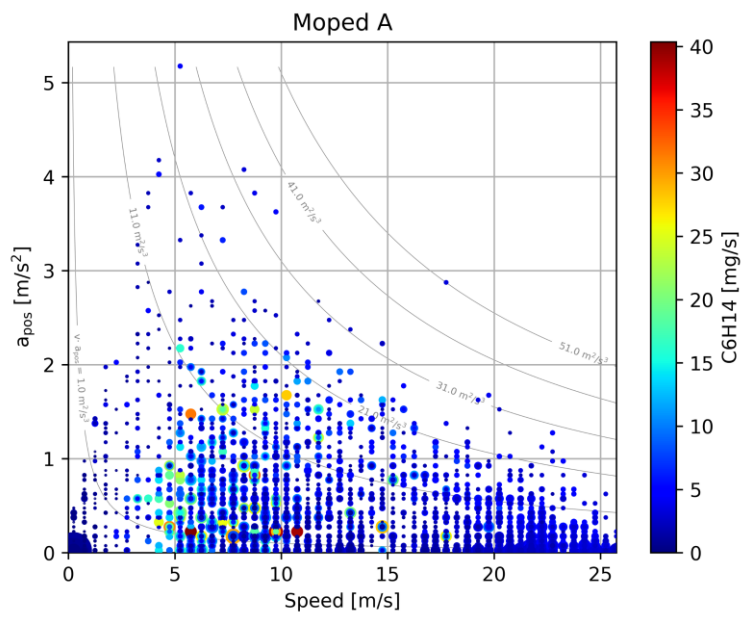

Figure C-23: HC emissions of moped A



RDE data of moped B

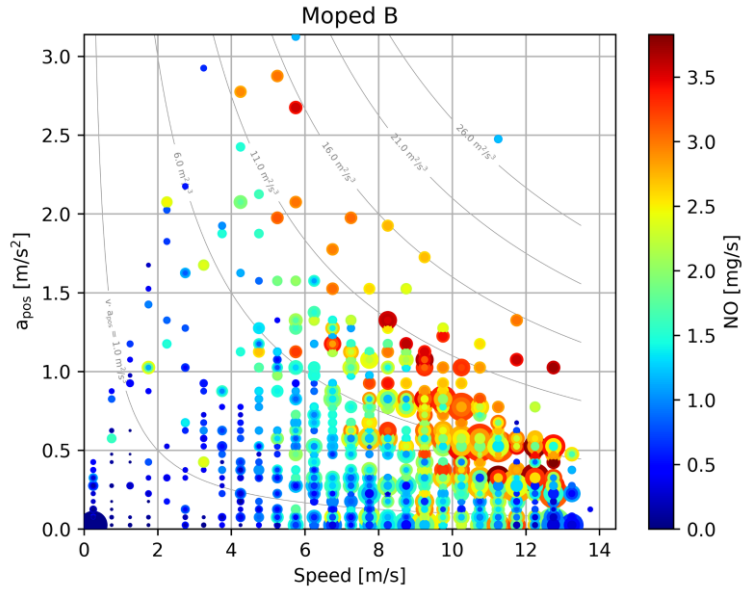

Figure C-24: NO emissions of moped B

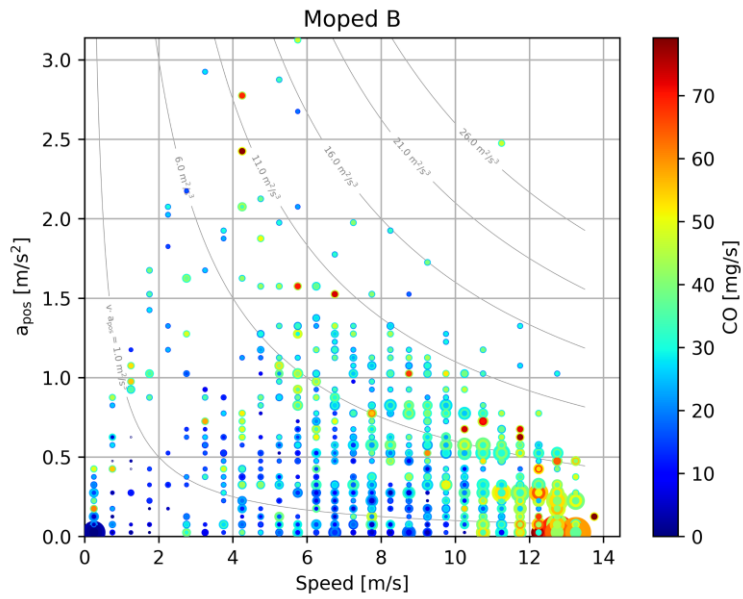

Figure C-25: CO emissions of moped B



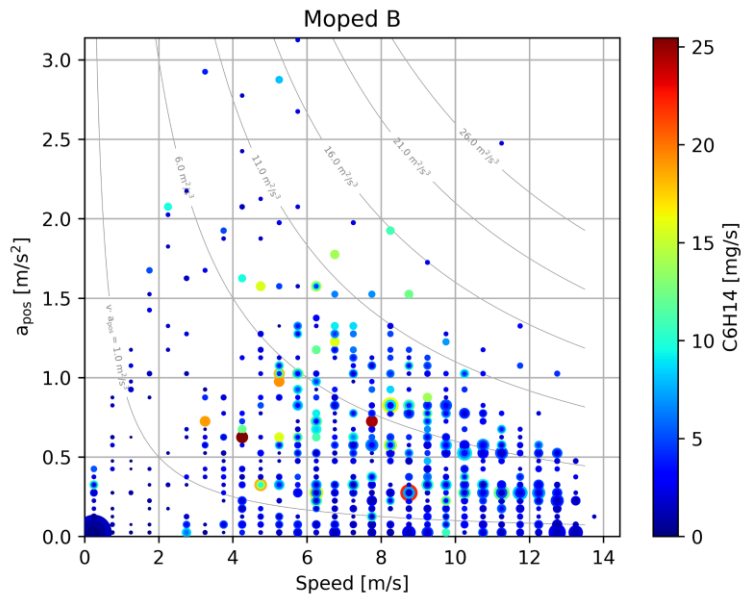

Figure C-26: HC emissions of moped B

RDE data of moped C

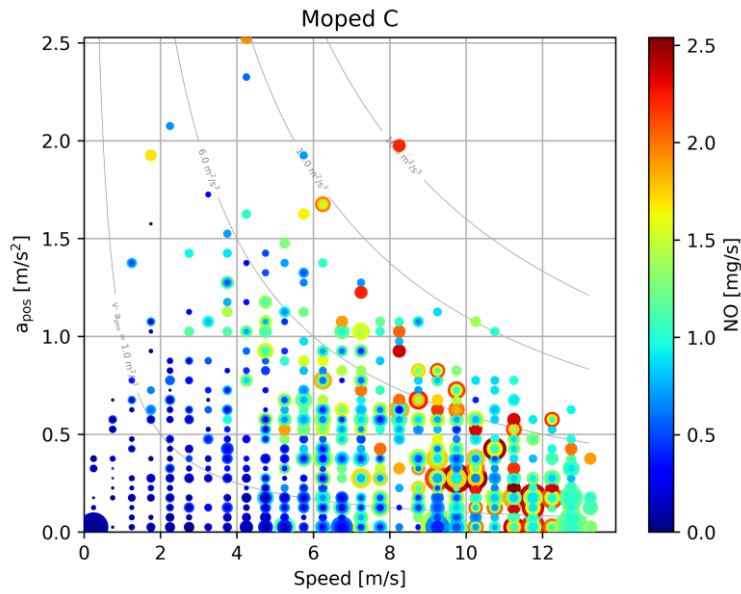

Figure C-27: NO emissions of moped C



This project has received funding from the European Union's Horizon Europe research and innovation programme under grant agreement No 101056777

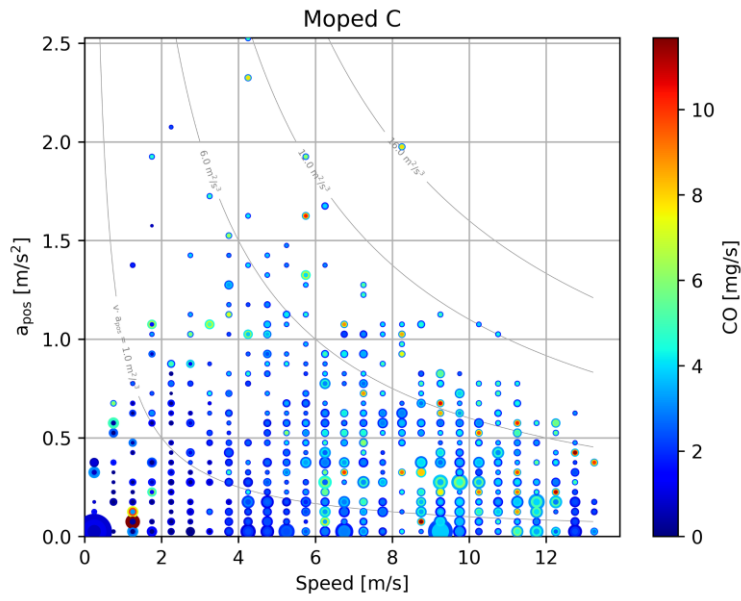

Figure C-28: CO emissions of moped C

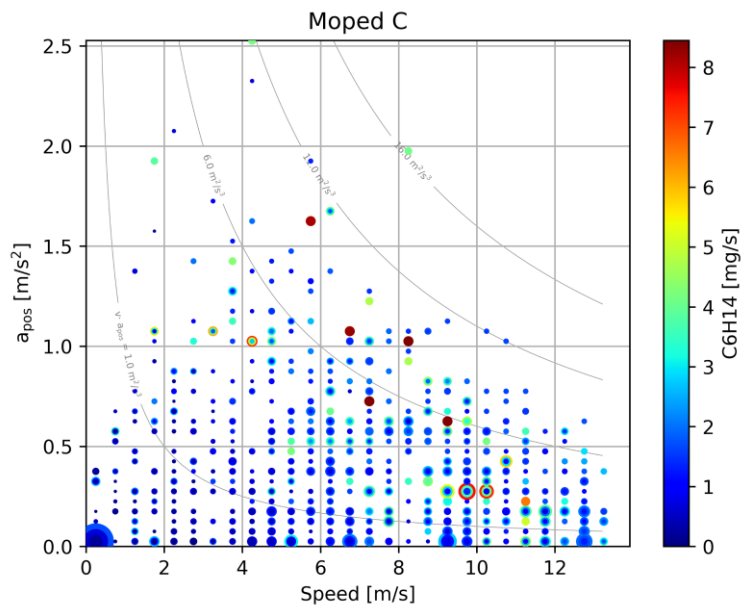

Figure C-29: HC emissions of moped C

